

DM212

DUAL MONITOR DESKTOP MOUNT WITH EXTENSION ARMS

Item ref: 129.523UK

User Manual

This dual armed bracket is suitable for most 10" to 30" LED/LCD screens and features adjustable height, tilt and swivel, allowing the screen to be easily positioned and free up valuable desk space making for a more comfortable viewing experience.

- Suitable for LED/LCD screen sizes 10" - 30"
- VESA 75 and 100 hole patterns
- -85° to 15° tilt mechanism
- 180° pan from mounting plate
- 180° swivel from centre arm joint
- Desk fixing clamp with 100mm max. depth adjustment
- Cable retainer
- Installation hardware included

Caution

Please read this manual thoroughly to avoid damage to property or personnel. If unsure of any part of this manual please refer to professional installer for help:

- This product contains small components that could pose a choking hazard if swallowed, please keep out of reach of children.
- This product is designed for mounting on wall studs or concrete wall. Always ensure the mounting surface will be capable of withstanding the combined weight of the TV bracket and TV, reinforcement may be required for aged or weak walls.
- Safety gear such as gloves and safety goggles must be worn during the installation. A minimum of two people are required throughout the installation, failure to do so may result in injury or damage.
- This product is design for indoor use only. The bracket must be inspected at least every two months for loose joints or aged parts.

Contents

Please check all contents listed below are included inside the box. If anything is missing please return to the retailer or dealer.

For this installation you will also require a Philips (cross) screw driver.

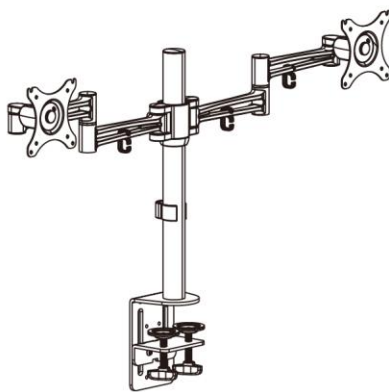

IN THE BOX:

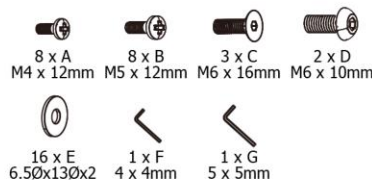

1. 1 x tube cap
2. 2 x TV plate
3. 1 x stopper
4. 1 x tube
5. 1 x tube clip
6. 1 x base
7. 1 x clamp screws
8. 2 x rubber desk protectors
9. 4 x cable clips
10. 4 x hinge caps

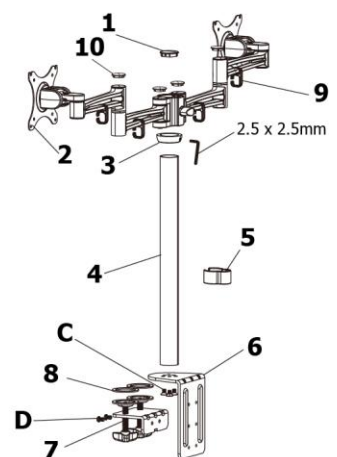

STEP 1 – Assemble and fit the desk clamp

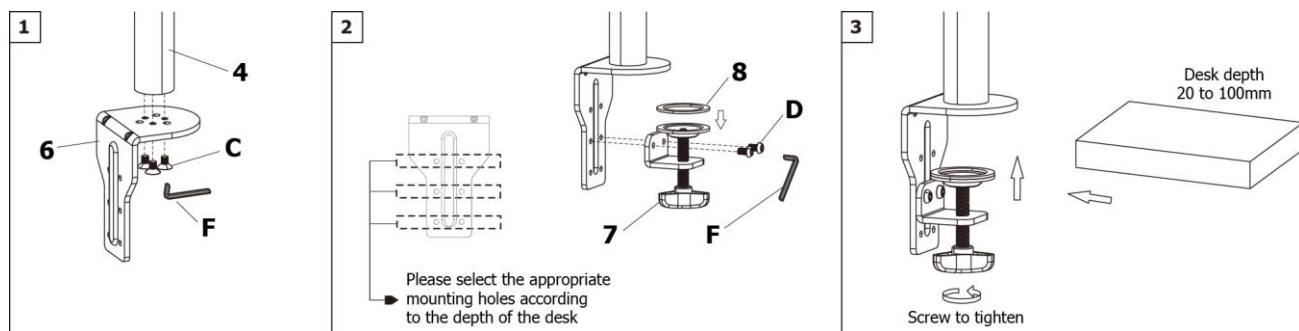

STEP 2 – Assemble and install the extension arms

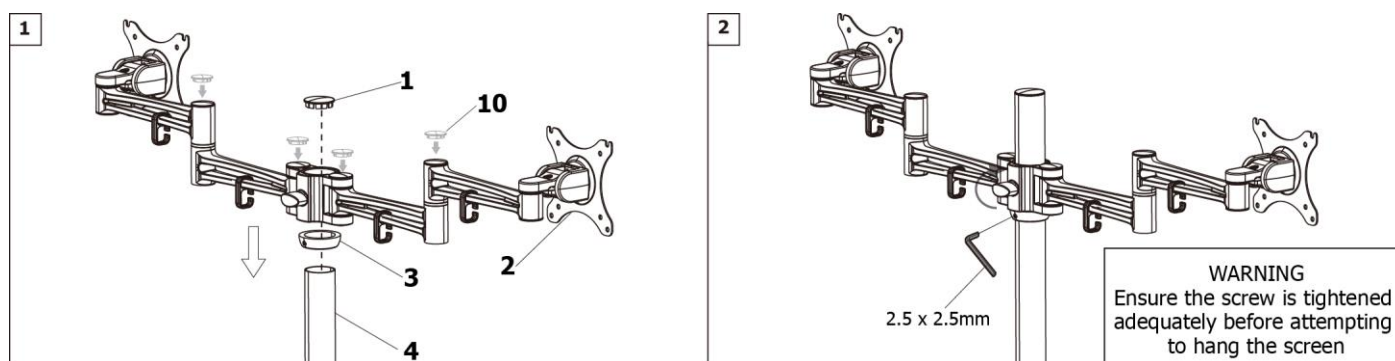

STEP 3 – Attach mounting plates to the screens or monitors

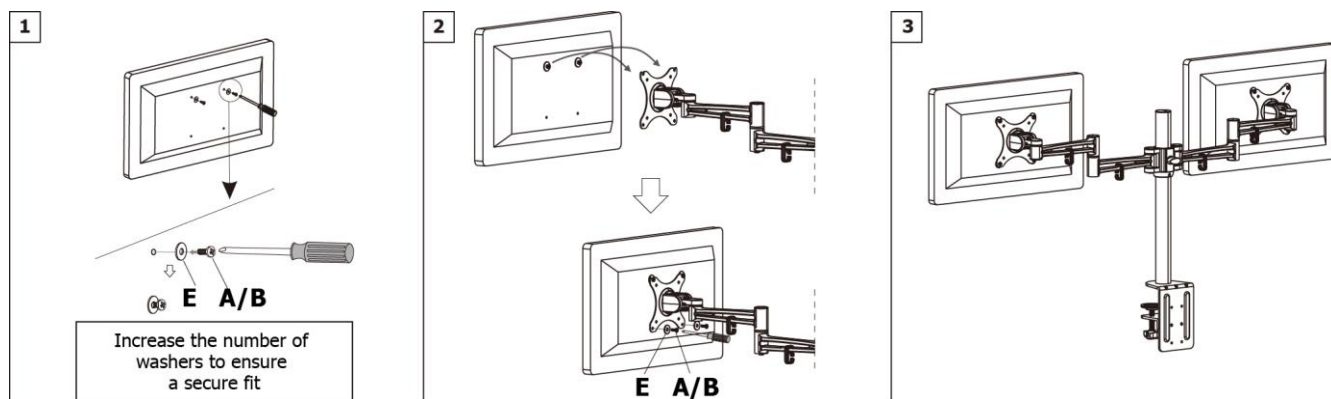

STEP 4 – Adjust screens to preferred position

