

FRES200WW Instruction Manual

PERFORM
FX



200 Watt Warm White LED Fresnel



CAUTION - ATTENTION - VORSICHT

**RISK OF ELECTRIC SHOCK- DO NOT OPEN
RISQUE D'ELECTROCUTION- NE PAS OUVRIR
STROMSCHLAGEFAHR- NICHT OFFNEN**



**In Compliance with the following directives: RoHS Directive
(2002/95/EU) and WEEE Directive (2002/96/EU)
If this product is no longer functional or reaches the end of its
usable life, please take it to an approved recycling plant.**

CE

RoHS
UK
CA

Version 1.0

www.terralec.co.uk

Dear Customer,

Thank you for purchasing the Perform FX FRES200WW LED Fresnel. With decades of experience in design and production, Perform FX is one of the leading manufacturers of Professional Lighting and Effects equipment. This unit has been designed and manufactured to the highest standards so you can be assured you have made a good investment.

For your safety and to ensure you make full use of the FRES200WW features, please make sure you read this manual in full.

Before Use

- Before you start using this unit, please check to ensure there's no transportation damage. Should there be any, do not use the device and consult with your dealer first.
- **Important: This device left our factory in perfect condition and well packaged. It is absolutely necessary for the user to strictly follow the safety instructions and warnings in this user manual. Any damage caused by mishandling is not subject to warranty. The dealer will not accept responsibility for any resulting defects or problems caused by disregarding this user manual.**
- Keep this booklet in a safe place for future consultation. If you sell the unit, be sure to add this user manual.
- To protect the environment, please try to recycle the packing material as much as possible.

Safety Instructions:

- Read this manual in full before operating this product.
- Keep this manual in a safe place for future reference.
- Heed all warnings and instructions, both in this manual and on the product.
- Carry and transport this product with care. Dropping this product may result in serious mechanical failure.
- The manufacturer accepts no responsibility for injury or damage caused as a result of not following the manual provided.
- Turn off and unplug this light from mains supply when not in use.
- This light is not waterproof and should not be used outside.
- Do **NOT** modify this product in any way.
- In the event of any liquid entering the housing, unplug immediately & contact a qualified engineer.

Protection from Fire:

- Do not place near sources of heat or ignition.
- Do not cover or block any ventilation holes.
- Check your AC wall socket will take the power you are applying to avoid overloading the mains supply.

Protection from Electric Shock:

- Only connect this unit to a mains socket with suitable trip and RCD protection.
- To disconnect from the mains socket, always remove by the mains plug. Do not attempt to remove by pulling the mains cable.
- Disconnect the unit from the mains supply before cleaning. Cleaning should be carried out with a soft, dry cloth.
- Do not expose this unit to any liquids.
- To prevent damage to the product or electric shock, do not expose or operate this device or its power supply to rain or moisture.
- Choose a suitable route for mains cables, ensuring trip hazards are avoided and the mains cable is not at risk of being crushed.
- Do not open this unit to service. There are no user serviceable parts inside. Any servicing or repairs should be carried out by a qualified engineer only. **Any attempt to service or adapt this unit will leave your warranty void** and could result in serious malfunction or injury.

Protection from Injury and Damage:

- Do not attempt to modify this unit.
- Always install the unit in a suitable location where vibrations to the unit are avoided.
- Check this unit matches the mains voltage and frequency before plugging it in to your mains socket.
- In the event that any object or liquid enters the machine, switch off immediately, remove from mains and consult a qualified engineer.
- Should you experience any malfunction or damage to the mains cable, disconnect from the mains supply immediately and consult a qualified engineer.
- All parts should be replaced with genuine spare parts and carried out by a qualified engineer.

Overhead Rigging:

- The installation must be carried out by a qualified engineer only. Improper installation can result in injuries or damage to property.
- Overhead rigging requires experience. Working loads should be adhered to, certified materials should be used.
- The installed device should be regularly inspected for safety.
- Make sure the working area is clear from people and obstructions during rigging, derigging and servicing.
- Locate the light in a well-ventilated area away from flammable materials and liquids.
- When mounting make sure the installation point can take the weight.
- Make sure a safety chain or wire is always used and can take the weight of the light.
- The light should be well fixed and free from swinging.
- Do not cover any ventilation holes.
- The light must not be powered when it is not to be used for an event.
- The operator must make sure the light fitting has been installed correctly to all the necessary guidelines before each use.
- **The installation should be inspected every 6 months.**

Product Information:

Contents and Unpacking:

Before beginning your initial setup, check the unit has not been damaged in transit. In the event there is damage to the housing, cable or internal components, contact your dealer immediately.

Contents:

- 1 x 200-Watt Fresnel Light
- 1x Mains Lead
- 1x User Manual
- 1x Barn Door

Product Description:

This 200 Watt cob LED Fresnel theatre spot is the perfect replacement for 1000 Watt conventional spots. The Perform FX FRES200WW spot uses a powerful 200 Watt cob warm light LED. The user can manually adjust the beam angle between 15 and 55 degrees. The light can be used manually or on a DMX Controller; all modes can be set in the easy to use display. There are 3 DMX modes to choose from and the theatre spot even has fan speed adjustment. The spot is housed in robust metal housing and is supplied with a hanging bracket and barn door.

Product Specification:

Power Supply: 100-240 Vac 50/60Hz

Power Consumption: 100 Watts

LED: 200 Watt COB LED

Beam Angle: 12-55 Degrees

Colour Temperature: 3200K

CRI: >90

DMX Channels: 1, 2 or 3

Dimensions: 385 x 270 x 427mm

Weight: 5.5kg

Notes:

1. When there is a flashing '!' sign, this means **no DMX signal is being received.**
2. After **30mins of not being used**, the **LCD display** will go into **sleep mode.**
3. When the **units' temperature is greater than the protecting circuit**, **30% of the power is reduced to the LED slowly.** Normal output will resume once the **internal temperature has lowered.**

Product Information:

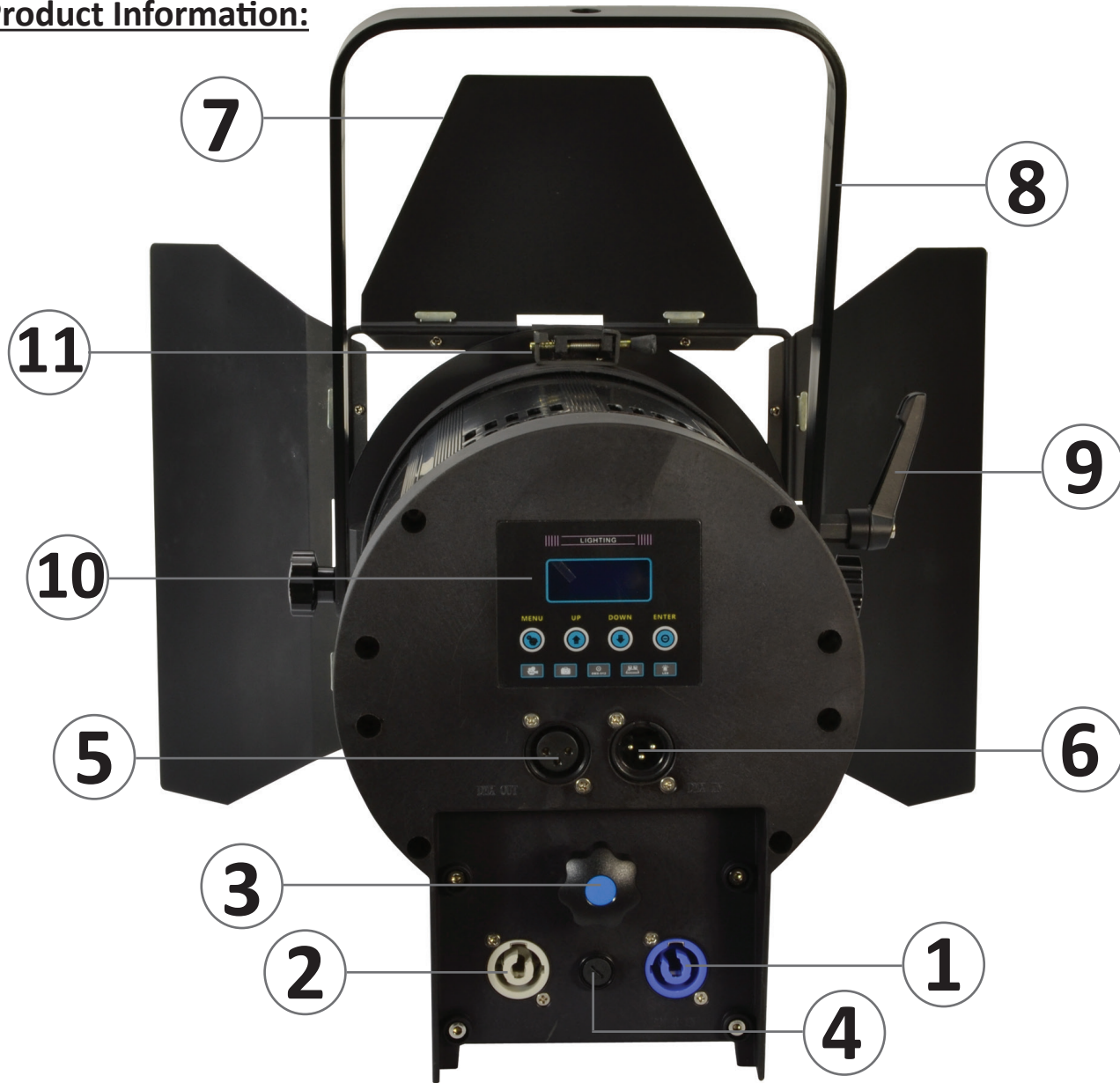

	Name	Use
1	Main Input	Equipped with professional Locking Connectors. Connect with the supplied cable or any suitable Neutrik PowerCon.
2	Mains Output	Used to daisy chain the power of several other projectors. Always pay attention to the maximum load.
3	Focus Knob	Used to adjust the beam angle.
4	Mains Fuse	Protects the unit in case of electrical problems. Always use the same fuse.
5	DMX Output	3 pin XLR output to daisy chain to other DMX lights.
6	DMX Input	3 pin XLR input to allow connection from other DMX lights or DMX Controller.
7	Barn Door	Facilitates shaping of the beam of light from the fixture. Prevents light spill into areas where they are not wanted.
8	Hanging Bracket	You can use the hole in the centre of the bracket to fix a hanging clamp.
9	Bracket Knob	Fasten the light into the desired position.
10	Display & Menu Buttons	Used to adjust the units settings.
11	Locking Clip	Used to keep the barn door and colour frame in place. Push to release.

Product Information:



	Name	Use
12	Menu Button	Used to enter the setup menu.
13	Up Button	Used to go to the previous menu or increase parameter value.
14	Down Button	Used to go to the next menu or decrease parameter value.
15	Enter Button	Used to select a menu option or confirm a setting.
16	Display	Shows the various menus and selected functions.

Menu Layout:

Menu			
1st Menu	2nd Menu	Value	Notes
DMX	DMX Address	0-512	Set DMX Address
CHAN	CH01		Dimmer
	CH02		Dimmer, DimmerFine
	CH03		Dimmer, DimmerFine, Strobe
MANUAL	DIM	0-255	Dimmer
	D_F	0-255	DimmerFine
	STO	0-255	Strobe
CURVE	Linear		Linear curve dimming
	Log		Logarithmic curve dimming
	S		S Curve Dimming
FADE	ON/OFF		
FRE	1.0K- 16K		1.0K Hz ~ 16K Hz frequency adjustment
FAN	Max		Max fan speed
	Auto		Fan speed automatically run according to fixture temperature
	Silent	120	Silent theatre mode
TEMP	C.000	0-255	Current temperature
RESET	YES/NO		Recover to manufactory default
Version			Software version number

DMX Layout Charts: *DMX512 Channel Table*

1CH Channel Table			
Channel	Value	Rate	Control Function
CH1	Dimmer	0-255	Dimmer, brightness from 0-100%
2CH Channel Table			
Channel	Value	Rate	Control Function
CH1	Dimmer	0-255	Dimmer, brightness from 0-100%
CH2	DimmerFine	0-255	Brightness micro-adjustment
3CH Channel Table			
Channel	Value	Rate	Control Function
CH1	Dimmer	0-255	Dimmer, brightness from 0-100%
CH2	DimmerFine	0-255	Brightness micro-adjustment
CH3	Strobe	0-255	0-255 Strobe frequency (from slow to fast)

DMX Basics:

DMX is short for “digital multiplexer”, which is a universal protocol designed for the entertainment industry. It allows control of intelligent fixtures like scanners, moving heads, LED par cans, dimmer packs and effects machines etc. DMX allows you to control many fixture channels, normally up to 512, with varying channels from 0-255 (0-100%). This will give control of channels such as gobo selection, movement, colours, dimming and timing to name just a few.

DMX is a very good system, as all this information can be sent down one cable. Used in conjunction with a DMX controller with memory, all your channel settings can be saved and recalled easily.

DMX was designed so that all manufacturers can use the same protocol/ language to control their fixtures, allowing the end user to use any make fixture from their DMX controller, as long as both are DMX compatible, and the controller has enough channels to control the fixture that is attached. Fixtures have an input and output DMX socket, allowing you to connect from the controller to the first fixture then from that fixture to the next (this is often referred to as ‘daisy chaining’). Sockets are normally 3 pin XLR but can be 5 pin XLR.

DMX fixtures need to have a DMX address set, this is so they can then decode the correct information from the controller. This is normally done by a digital display panel, where the address can be changed by simple up and down buttons; the system address ranges from 1-512. Alternatively, it may be controlled by a row of small switches, called dip switches; on this type of system, the required address is then converted to a binary number.

To work out your dip switch settings you can simply download a DMX calculator from the internet. The order in which fixtures are connected in a DMX line does not influence the DMX address, a fixture set to DMX address 1 can be put in a DMX line anywhere from beginning, middle to end. As long as it has its address set to 1, it knows to take information from that point onward.

3 Pin	5 Pin
Pin 1 GND	Pin 1 GND
Pin 2 -	Pin 2 -
Pin 3 +	Pin 3 +
	Not Used
	Not Used

DMX Wiring and Connections:

3 pin DMX wiring is more common, although using a 5 pin connector is better to stop confusion with audio leads. With 5 pin connections, not all pins are used, though it is worth checking your manual for your fixture, as some lights use the unused pins for low voltage control.

To avoid erratic behaviour from your fixture, ensure when making cables, you always use suitable DMX cables and do not connect pin 1 GND to the outer casing of the connector (as you may do with your audio cables). Do not make “Y” leads to split cable fixtures; always use the in and out sockets or a DMX splitter.

We also recommend you put a DMX terminator in any fixture which does not have a DMX lead connected from the output socket to another fixture; to reduce unexpected behaviour. A DMX terminator is simply a male XLR plug with 120 Ohms, ¼ watt resistor, soldered across pins 2 and 3. You can also buy these pre-made.

Example of a DMX Fixture with 5 Channels:

Ch1	Ch2	Ch3	Ch4	Colour	
Pan	Tilt	Shutter/Shaking	Gobo	Normal	Split
540°	270°	246-255 Open	255 Fastest speed Gobo change	255 Fastest speed Rainbow Effect	255 Fastest speed Rainbow Effect
		247 Fastest speed shaking			
			120-127	128 Slowest speed Rainbow effect	128 Slowest speed Rainbow effect
		132 Slowest speed shaking	111-119	118-127 Pink	121-127 Pink
			103-110	107-117 Yellow	113-120 Yellow+Pink
		131 Fastest speed shutter	094-102	096-106 Orange	106-112 Yellow
			086-083	086-095 Light Green	098-105 Orange+Yellow
		16 Slowest speed shutter	077-085	075-085 UV Purple	083-090 Light Green+Orange
			069-076	064-074 Blue	076-082 Light Green
		008-015 Open	060-068	054-063 Red	068-075 UV Purple
			052-059	043-053 Amber	061-067 Blue
		000-007 Blackout	044-051	032-042 Light Blue	053-060 Red+Blue
0°	0°		035-043	022-031 Magenta	046-052 Red
			0-26-034	011-021 Green	038-045 Amber
			018-025	000-010 White	031-037 Light Blue
			009-017		023-030 Magenta
			000-008		016-022 Green+Magenta
					008-016 Green
					000-007 White

Each fixture takes up to 5 DMX Channels (see above):

You have a cable from the controller to the first fixture cable, then from first to second and so on. The last light then has a DMX terminator plugged in.

Example of a DMX Line

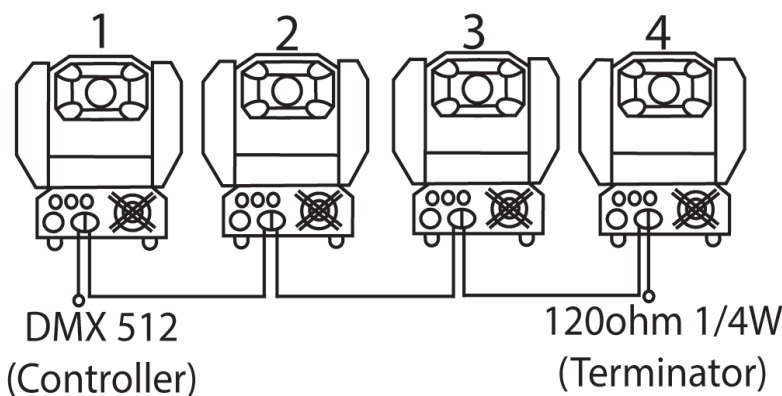

Fixture 1 would be set to DMX address:
DMX Address 1
 Fixture 2 would be set to DMX address:
DMX Address 6
 Fixture 3 would be set to DMX address:
DMX Address 11
 Fixture 4 would be set to DMX address:
DMX Address 16

We recommend you to read manuals for your DMX fixture and controller in full. Some controllers tell you what each fixture address needs to be, and some lights need other settings changed before they will work.

When setting your DMX address, you must ensure fixtures don't overlap from one to the next. You can set two fixtures to the same address, and as long as they are the same fixture (i.e. same channel layout) then they will do the same as each other.

**Thank you for taking the time to read this information.
For further information, please contact sales@terralec.com or visit
www.terralec.co.uk**