

elumen8

MP180 LED Fresnel RGBALC

User Manual



Order code: ELUM112

WARNING

FOR YOUR OWN SAFETY, PLEASE READ THIS USER MANUAL CAREFULLY BEFORE YOUR INITIAL START-UP!

- Before your initial start-up, please make sure that there is no damage caused during transportation.
- Should there be any damage, consult your dealer and do not use the equipment.
- To maintain the equipment in good working condition and to ensure safe operation, it is necessary for the user to follow the safety instructions and warning notes written in this manual.
- Please note that damages caused by user modifications to this equipment are not subject to warranty.



IMPORTANT:

The manufacturer will not accept liability for any resulting damages caused by the non-observance of this manual or any unauthorised modification to the equipment.

- Never let the power cable come into contact with other cables. Handle the power cable and all mains voltage connections with particular caution!
- Never remove warning or informative labels from the unit.
- Do not open the equipment and do not modify the unit.
- Do not connect this equipment to a dimmer pack.
- Do not switch the equipment on and off in short intervals, as this will reduce the system's life.
- Only use the equipment indoors.
- Do not expose to flammable sources, liquids or gases.
- Always disconnect the power from the mains when equipment is not in use or before cleaning! Only handle the power-cable by the plug. Never pull out the plug by pulling the power-cable.
- Make sure that the available mains supply voltage is between 110~240V AC, 50/60Hz.
- Make sure that the power cable is never crimped or damaged. Check the equipment and the power cable periodically.
- If the equipment is dropped or damaged, disconnect the mains power supply immediately and have a qualified engineer inspect the equipment before operating again.
- If the equipment has been exposed to drastic temperature fluctuation (e.g. after transportation), do not connect power or switch it on immediately. The arising condensation might damage the equipment. Leave the equipment switched off until it has reached room temperature.
- If your product fails to function correctly, stop use immediately. Pack the unit securely (preferably in the original packing material), and return it to your Pro Light dealer for service.
- Only use fuses of same type and rating.
- Repairs, servicing and power connection must only be carried out by a qualified technician. THIS UNIT CONTAINS NO USER SERVICEABLE PARTS.
- This lighting fixture is for professional use only - it is not designed for or suitable for household use. The product must be installed by a qualified technician in accordance with local territory regulations. The safety of the installation is the responsibility of the installer. The fixture presents risks of severe injury or death due to fire hazards, electric shock and falls.
- Warning! Risk Group 2 LED product according to EN 62471. Do not view the light output with optical instruments or any device that may concentrate the beam.
- WARRANTY: Two years from date of purchase.

OPERATING DETERMINATIONS

If this equipment is operated in any other way, than those described in this manual, the product may suffer damage and the warranty becomes void. Incorrect operation may lead to danger e.g: short-circuit, burns and electric shocks etc.

Do not endanger your own safety and the safety of others!

Incorrect installation or use can cause serious damage to people and/or property.

MP180 LED Fresnel RGBALC

The MP180 is a full colour RGBALC fresnel style fixture that is perfect for short throw applications including studios and theatres. High quality dimming allows for smooth fades and a zoom with adjustable 13° – 46° beam angle places an even field of light wherever needed. The addition of amber, lime and cyan within the LED source make for perfect colour mixing on any scene or subject. These fixtures provide a superb light output and benefit from temperature controlled fan cooling for whisper quiet operation.

- 1 x 180W six-colour COB LED (RGBALC)
- Manually adjustable beam angle: 13° - 46°
- 13° - 6,849 Lux @ 2m, 46° - 2,141 Lux @ 2m
- CRI: 80
- 17kHz refresh rate
- DMX channels: 1/5/6 or 16 selectable
- RDM (Remote Device Management)
- 0 - 100% 8 or 16 bit dimming and variable strobe
- 4 dimming curves in both LED and halogen profiles: Linear, square law, inverse square law and S-curve
- 4 push button menu with LCD display
- PowerCON input/output
- 5-Pin XLR input/output
- 3-Pin XLR input/out
- Temperature controlled fan
- Filter frame and barn doors included



13° - Lux					
FULL ON	27400	9849	3040	1710	1100
R	4080	1022	453	255	163
G	8520	2125	947	533	341
B	2190	548	244	137	87.7
A	16600	4158	1850	1040	666
L	25832	6458	2870	1614	1033
C	4940	1235	548	308	197

46° - Lux					
FULL ON	8560	2141	951	535	342
R	1730	431.5	192	108	69.1
G	2670	668.3	297	167	107
B	712	177.6	79.1	44.5	28.5
A	5200	1296	578	325	208
L	8080	2019	898	505	323
C	15400	383.9	1710	960	614

Specifications	MP180 LED Fresnel RGBALC
Power consumption	190W
Power supply	100~240V, 50/60Hz
Fuse	T3A 250V
Dimensions	371 x 301 x 318mm (with bracket) 298 x 245 x 318mm (without bracket)
Weight	8.7kg
Order code	ELUM112

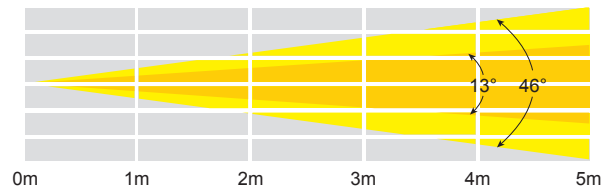

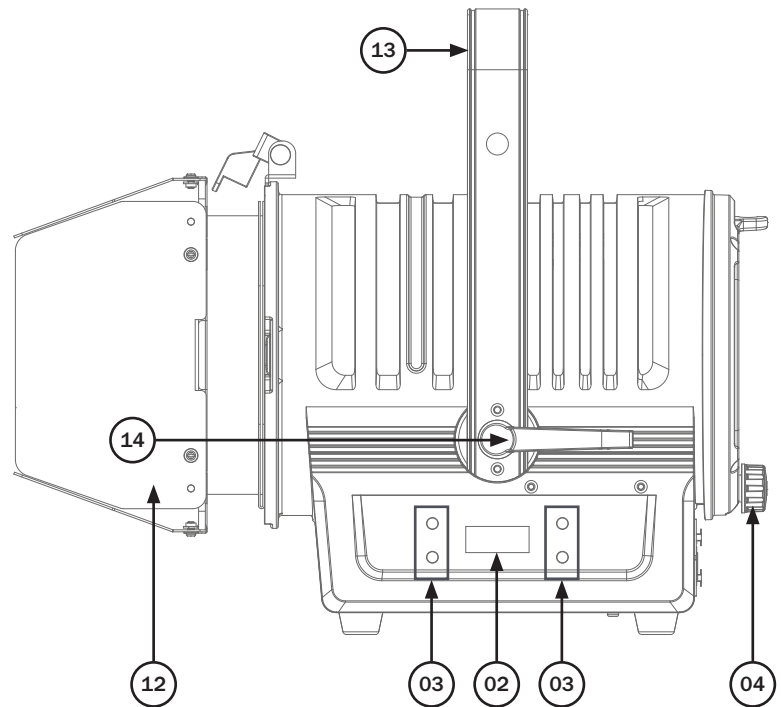
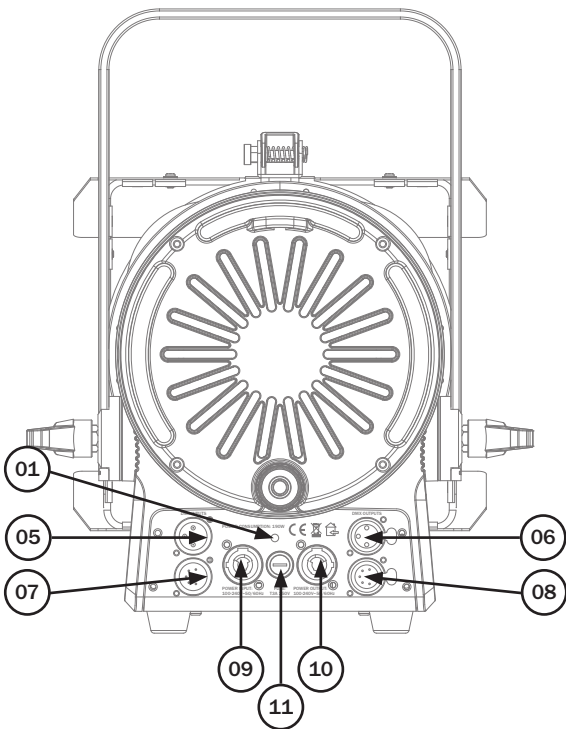
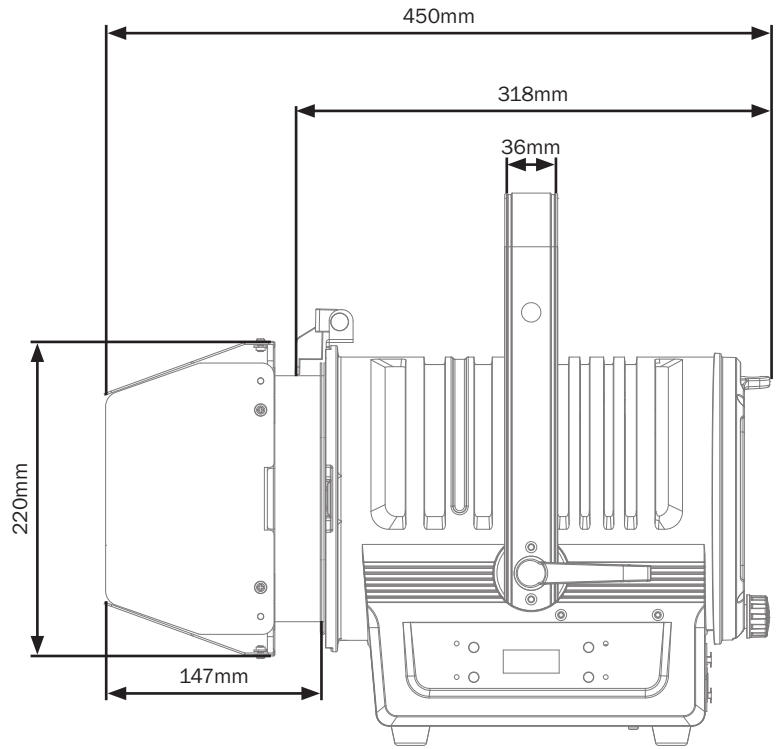
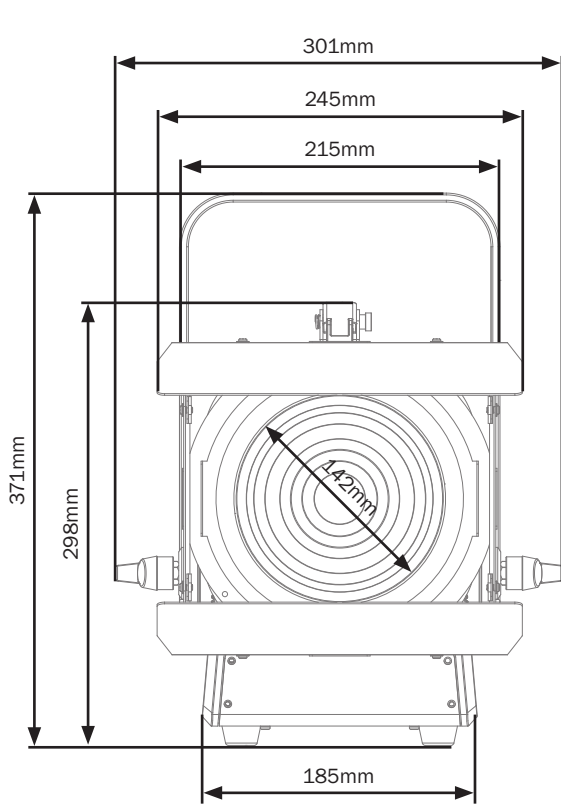

- 01 - Earth point
- 02 - LCD display
- 03 - Function buttons
- 04 - Function knobs
- 05 - 3-Pin DMX input
- 06 - 3-Pin DMX output
- 07 - 5-Pin DMX input
- 08 - 5-Pin DMX output
- 09 - PowerCON input
- 10 - PowerCON output

- 11 - Fuse T3A 250V
- 12 - Barn doors
- 13 - Hanging bracket
- 14 - Hanging bracket adjustable knob

In the box: **1 x fixture**,
1 x barn door
1 x PowerCON cable
& 1 x user manual

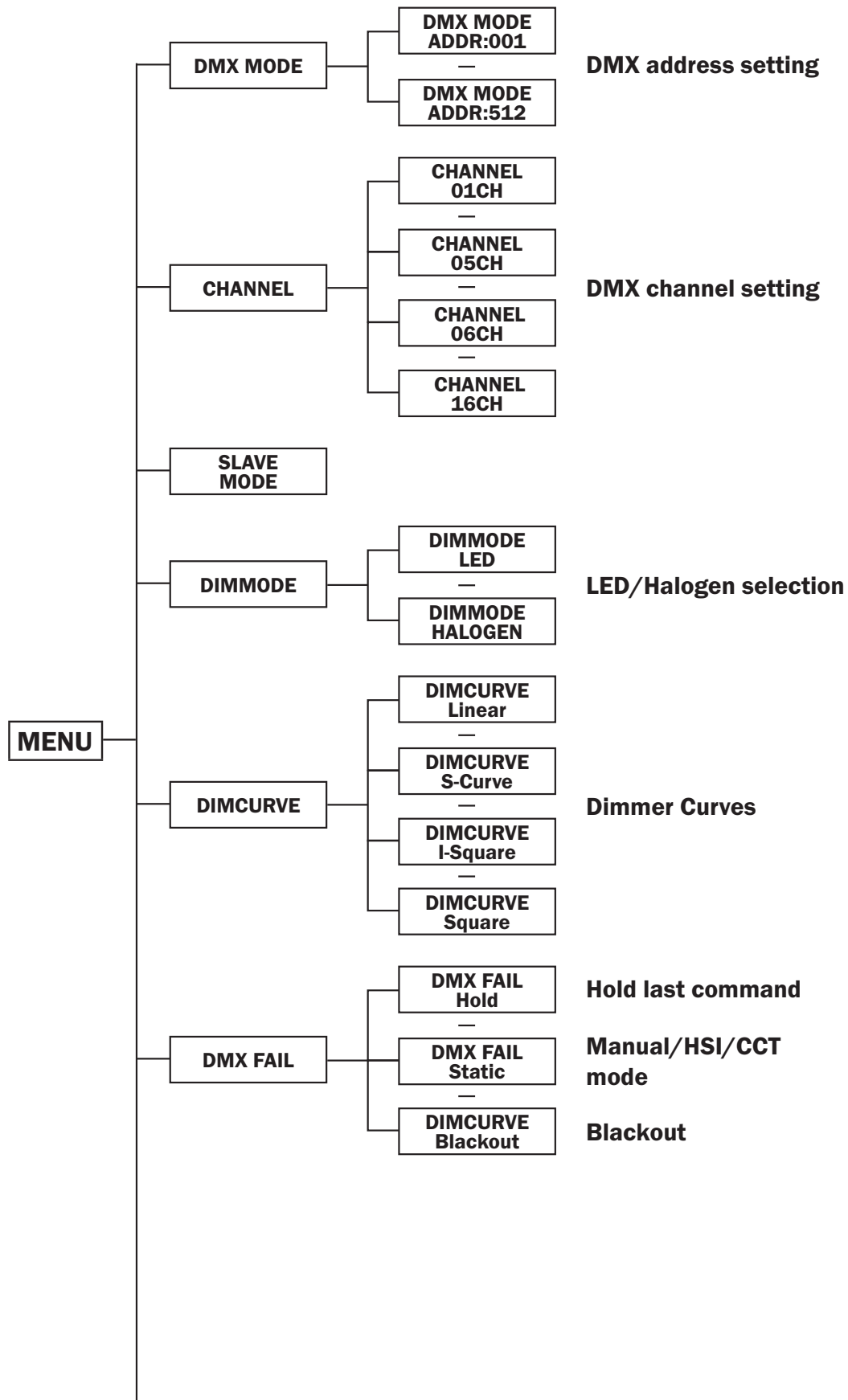

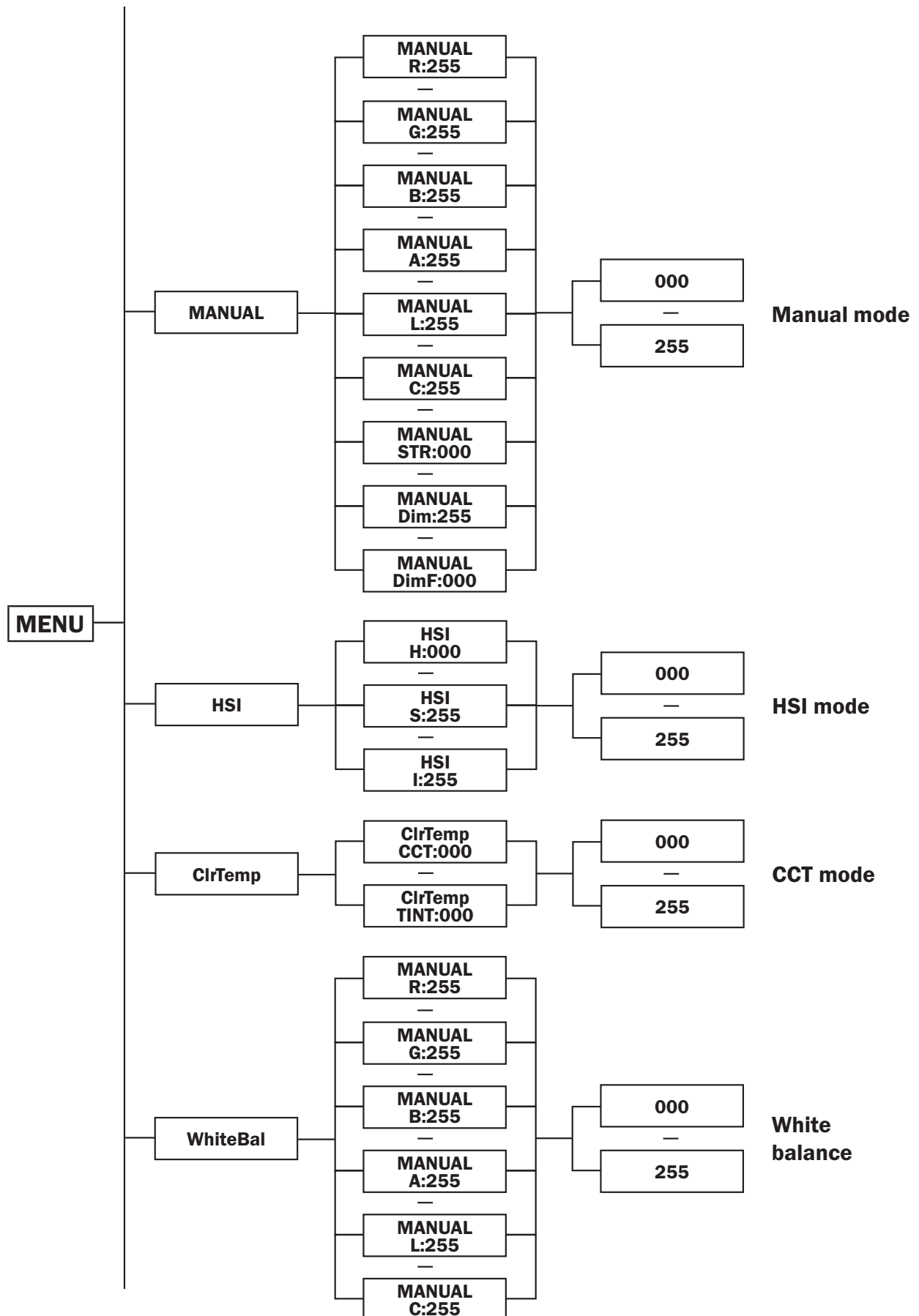

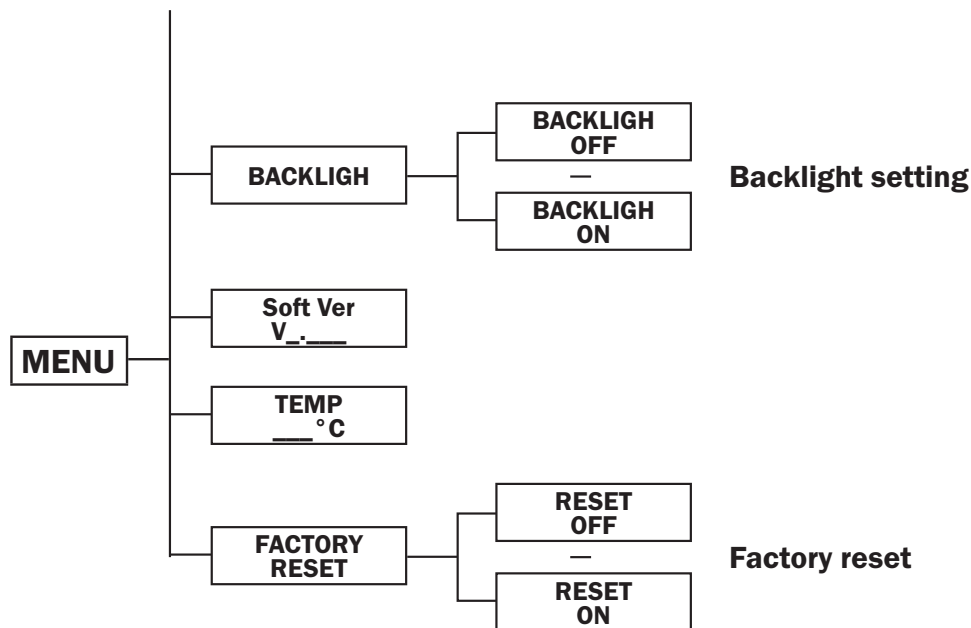

DMX mode:

Operating in a DMX control mode environment gives the user the greatest flexibility when it comes to customising or creating a show. In this mode you will be able to control each individual trait of the fixture and each fixture independently.

To access the DMX address mode, press the “**MENU**” button to show “**DMX MODE**” on the LCD display. Now press the “**ENTER**” button and use the “**UP**” and “**DOWN**” buttons to set the required DMX address. Press the “**ENTER**” button to confirm the setting.

To access the DMX channel mode, press the “**MENU**” button to show “**CHANNEL**” on the LCD display. Now press the “**ENTER**” button and use the “**UP**” and “**DOWN**” buttons to set the required DMX channel. Press the “**ENTER**” button to confirm the setting.

To choose what the fixture does when it loses DMX signal, press the “**MENU**” button to show “**DMX FAIL**” on the LCD display. Now press the “**ENTER**” button and use the “**UP**” and “**DOWN**” buttons to choose between “**HOLD**”, “**STATIC**” or “**BLACKOUT**”.

Press the “**ENTER**” button to confirm the setting.

To exit out of any of the above options, press the “**MENU**” button.

Please note: when no DMX signal is present the display will flash.

1 channel mode:

Channel	Value	Function
1	000-255	Master dimmer (0-100%)

5 channel mode:

Channel	Value	Function
1	000-255	Hue
2	000-255	Saturation
3	000-255	Intensity
4	000-005	No function
	006-255	CCT (2800-8000K)
5	000	No function
	001-255	Tint (100-0-100%) 001 - magenta 128 - neutral 255 - green

6 channel mode:

Channel	Value	Function
1	000-255	Red dimmer (0-100%)
2	000-255	Green dimmer (0-100%)
3	000-255	Blue dimmer (0-100%)
4	000-255	Amber dimmer (0-100%)
5	000-255	Lime dimmer (0-100%)
6	000-255	Cyan dimmer (0-100%)

16 channel mode:

Channel	Value	Function
1	000-255	Master dimmer (0-100%)
2	000-255	Dimmer fine (0-100%)
3	000-005	LED on
	006-255	Strobe (slow-fast)
4	000-255	Red dimmer (0-100%)
5	000-255	Green dimmer (0-100%)
6	000-255	Blue dimmer (0-100%)
7	000-255	Amber dimmer (0-100%)
8	000-255	Lime dimmer (0-100%)
9	000-255	Cyan dimmer (0-100%)
10	000-005	No function
	006-255	CCT (2800-8000K)
11	000	No function
	001-255	Tint (100-0-100%) 001 - magenta 128 - neutral 255 - green
12	000-255	Hue
13	000-255	Saturation
14	000-255	Intensity
15	000-005	No function
	006-063	Linear dimmer curve (hold 3s)
	064-127	Square dimmer curve (hold 3s)
	128-191	I-Square dimmer curve (hold 3s)
192-255	S-Curve dimmer curve (hold 3s)	
16	000-005	No function
	006-063	LED dimmer mode (hold 3s)
	064-127	Halogen dimmer mode (hold 3s)
	128-255	No function

Master/slave mode:

To set the master unit, put the fixture into manual/HSI/CCT mode.

To set the other units in slave mode, press the “MENU” button and use the “UP” and “DOWN” buttons to show “SLAVE MODE” on the LCD display. Press the “ENTER” button to confirm the setting. The unit will now run in sequence with the master unit.

To exit out of any of the above options, press the “MENU” button.

Please ensure that all slave units are set to the same DMX channel mode as the master unit.

Dimming curves

To access the units dimmer curves, press the “**MENU**” button to show “**DIMCURVE**” on the LCD display. Press the “**ENTER**” button and use the “**UP**” and “**DOWN**” buttons to set the dimming curve required.

“**Linear**” - Linear dimming curve

“**S-Curve**” - S-Curve dimming curve

“**I-Square**” - Inverse Square dimming curve

“**Square**” - Square dimming curve

Press the “**ENTER**” button to confirm the setting.

To choose between Halogen and LED dimmer curves, press the “**MENU**” button to show “**DIMMODE**” on the LCD display. Press the “**ENTER**” button and use the “**UP**” and “**DOWN**” buttons to set the dimming curve mode required.

“**LED**” - LED dimming curves

“**HALOGEN**” - Halogen dimming curves

Press the “**ENTER**” button to confirm the setting.

Manual mode:

To access manual mode, press the “**MENU**” button on to show “**MANUAL**” on the LCD display.

Press the “**ENTER**” button and use the “**UP**” and “**DOWN**” buttons to set the Red, Green, Blue, Amber, Lime, Cyan, Strobe, Dimmer and Dimmer Fine from “**000**” - “**255**”.

Press the “**ENTER**” button to confirm the setting.

(**000** = LED off, **255** = LED at full brightness).

(**000** = Strobe off, **255** = Strobe fast).

HSI mode:

To access HSI mode, press the “**MENU**” button on to show “**HSI**” on the LCD display.

Press the “**ENTER**” button and use the “**UP**” and “**DOWN**” buttons to set the Hue, Saturation and Intensity from “**000**” - “**255**”. Press the “**ENTER**” button to confirm the setting.

CCT mode:

To access CCT mode, press the “**MENU**” button on to show “**CirTemp**” on the LCD display.

Press the “**ENTER**” button and use the “**UP**” and “**DOWN**” buttons to set the CCT and Tint from “**000**” - “**255**”. Press the “**ENTER**” button to confirm the setting.

(**001** = magenta, **128** = neutral, **255** = green)

White balance:

To access white balance mode, press the “**MENU**” button on to show “**WhiteBal**” on the LCD display.

Press the “**ENTER**” button and use the “**UP**” and “**DOWN**” buttons to set the Red, Green, Blue, Amber, Lime, and Cyan from “**000**” - “**255**”. Press the “**ENTER**” button to confirm the setting.

To exit out of any of the above options, press the “**MENU**” button.

Backlight:

To access the backlight setting, press the “**MENU**” button to show “**BACKLIGH**” on the LCD display. Press the “**ENTER**” button and use the “**UP**” and “**DOWN**” buttons to select between “**OFF**” or “**ON**”. Press the “**ENTER**” button to confirm the setting.

Software version:

To access the fixtures software version, press the “**MENU**” button and use the “**UP**” and “**DOWN**” buttons to show “**SOFT VER**” on the LCD display. The unit will now display the fixtures software version.

Fixture temperature:

To access the fixtures temperature, press the “**MENU**” button and use the “**UP**” and “**DOWN**” buttons to show “**TEMP**” on the LCD display. The unit will now display the fixtures temperature.

Factory reset:

To access factory reset, press the “**MENU**” button on the rear of the unit to show “**FACTORY RESET**” on the LCD display. Press the “**ENTER**” button and use the “**UP**” and “**DOWN**” buttons to select “**ON**”. Press the “**ENTER**” button to confirm the setting. The fixture will reset to factory default settings. To exit out of any of the above options, press the “**MENU**” button.

Setting the DMX address:

The DMX mode enables the use of a universal DMX controller. Each fixture requires a “start address” from 1- 512. A fixture requiring one or more channels for control begins to read the data on the channel indicated by the start address. For example, a fixture that occupies or uses 7 channels of DMX and was addressed to start on DMX channel 100, would read data from channels: 100, 101, 102, 103, 104, 105 and 106. Choose a start address so that the channels used do not overlap. E.g. the next unit in the chain starts at 107.

DMX 512:

DMX (Digital Multiplex) is a universal protocol used as a form of communication between intelligent fixtures and controllers. A DMX controller sends DMX data instructions from the controller to the fixture. DMX data is sent as serial data that travels from fixture to fixture via the DATA “IN” and DATA “OUT” XLR terminals located on all DMX fixtures (most controllers only have a data “out” terminal).

DMX linking:

DMX is a language allowing all makes and models of different manufactures to be linked together and operate from a single controller, as long as all fixtures and the controller are DMX compliant. To ensure proper DMX data transmission, when using several DMX fixtures try to use the shortest cable path possible. The order in which fixtures are connected in a DMX line does not influence the DMX addressing. For example; a fixture assigned to a DMX address of 1 may be placed anywhere in a DMX line, at the beginning, at the end, or anywhere in the middle. When a fixture is assigned a DMX address of 1, the DMX controller knows to send DATA assigned to address 1 to that unit, no matter where it is located in the DMX chain.

DATA cable (DMX cable) requirements (for DMX operation):

This fixture can be controlled via DMX-512 protocol. The DMX address is set on the back of the unit. Your unit requires either a standard 3-pin or 5-pin XLR connector for data input/output, see images below.

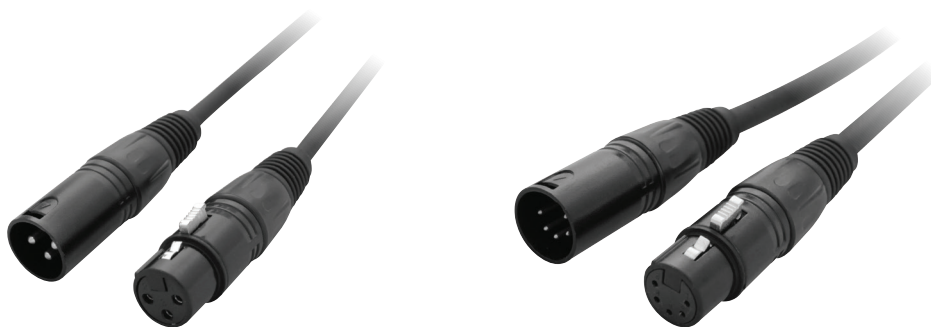

Further DMX cables can be purchased from all good sound and lighting suppliers or Prolight Concepts dealers.

Please quote:	3-Pin:	CABL10 - 2m	CABL11 - 5m	CABL12 - 10m
	5-Pin:	CABL185 - 2m	CABL187 - 5m	CABL188 - 10m

Also remember that DMX cable must be daisy chained and cannot be split.

Notice:

Be sure to follow the diagrams below when making your own cables. Do not connect the cables shield conductor to the ground lug or allow the shield conductor to come in contact with the XLRs outer casing. Grounding the shield could cause a short circuit and erratic behaviour.

Pin Configuration	
3-Pin	5-Pin
	Pin 1 - Ground
	Pin 2 - Negative
	Pin 3 - Positive
-	Pin 4 - N/C
-	Pin 5 - N/C

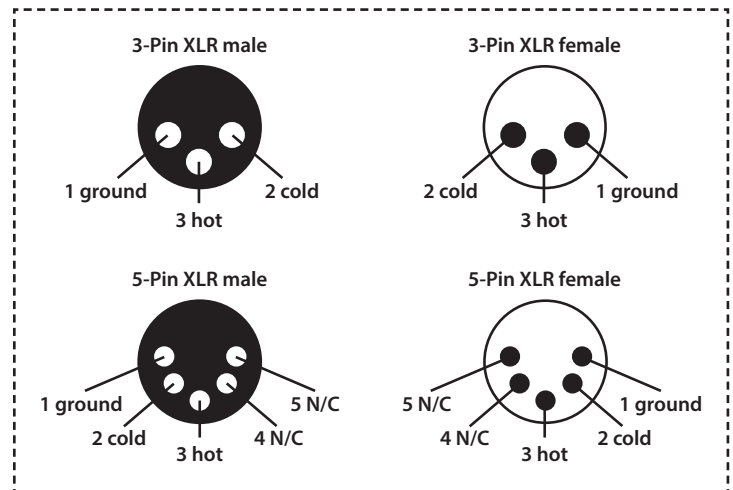
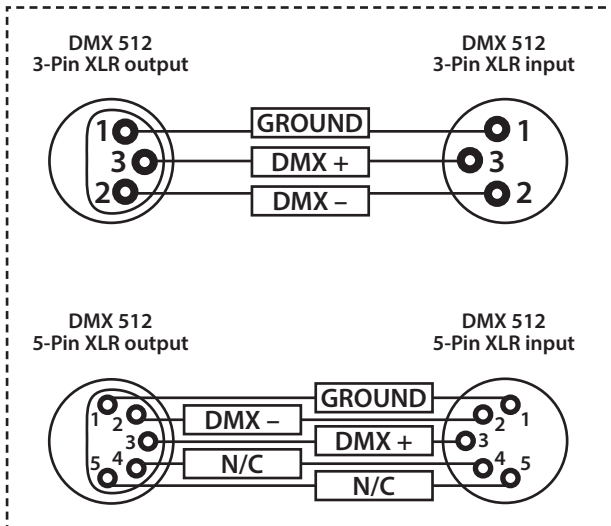

Line termination:

When longer runs of cable are used, you may need to use a terminator on the last unit to avoid erratic behaviour.

Using a cable terminator will decrease the possibilities of erratic behaviour.

(3-pin - Order ref: CABL90,
5-pin - Order ref: CABL89)

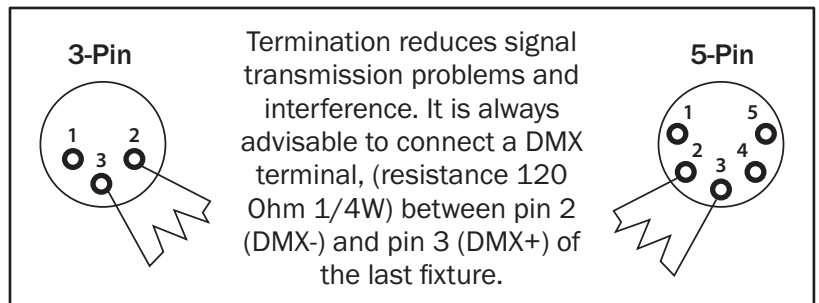

5-pin XLR DMX connectors:

Some manufactures use 5-pin XLR connectors for data transmission in place of 3-pin. 5-pin XLR fixtures may be implemented in a 3-pin XLR DMX line. When inserting standard 5-pin XLR connectors in to a 3-pin line a cable adaptor must be used. The diagram below details the correct cable conversion.

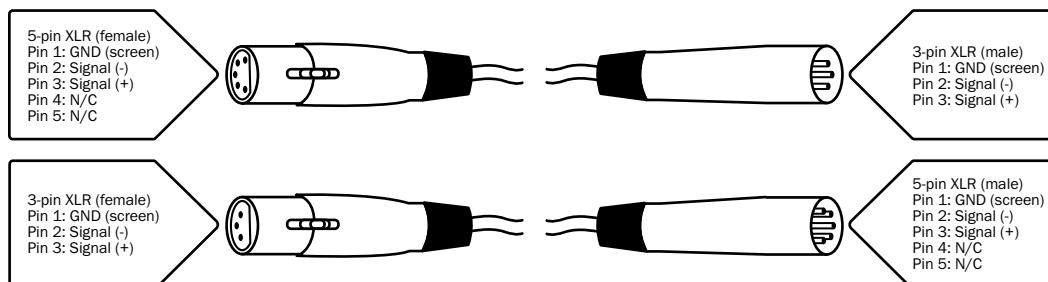

Power linking:

This fixture provides power linking via the power output on the rear allowing multiple units to be connected together. The maximum number of fixtures that can be connected is 12 fixtures @ 240V or 6 fixtures @ 120V (including the first fixture). After the maximum number of fixtures are connected a new power run will need to be started.

Please note: Caution should be used when power linking other fixtures to the MP180 LED Fresnel RGBALC as the power consumption of other fixtures will vary. Fixtures fitted with lamps often require 2/3 times more current on startup, these may require their own power source.

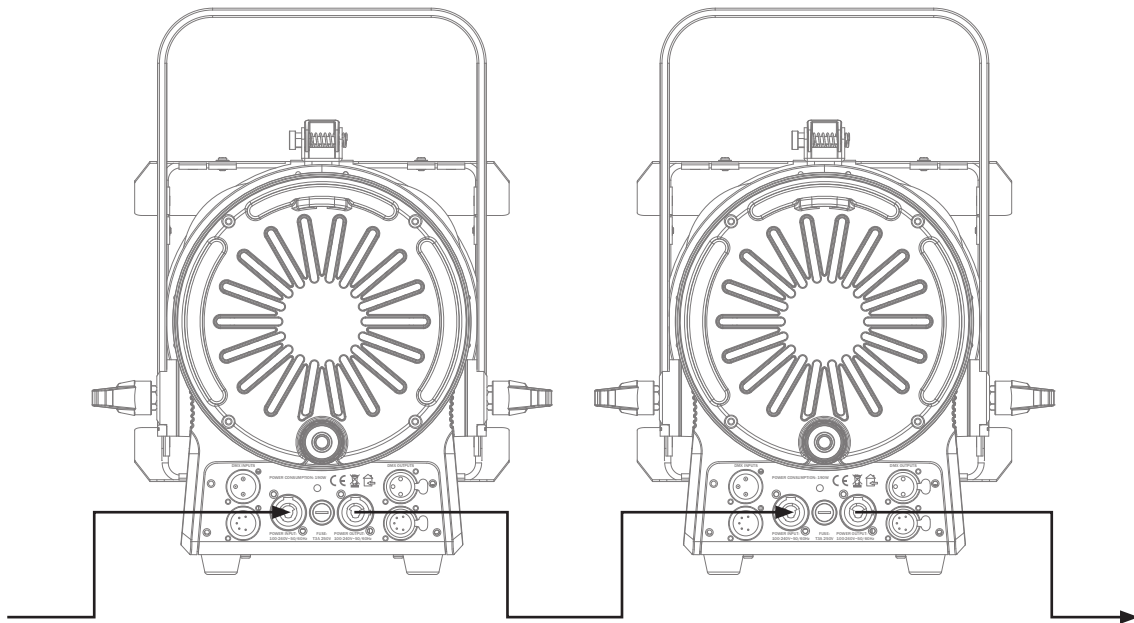



***Correct Disposal of this Product
(Waste Electrical & Electronic Equipment)***

**(Applicable in the European Union and other European countries
with separate collection systems)**

This marking shown on the product or its literature, indicates that it should not be disposed with other household wastes at the end of its working life. To prevent possible harm to the environment or human health from uncontrolled waste disposal, please separate this from other types of wastes and recycle it responsibly to promote the sustainable reuse of material resources.

Household users should contact either the retailer where they purchased this product, or their local government office, for details of where and how they can take this item for environmentally safe recycling.

Business users should contact their supplier and check the terms and conditions of the purchase contract. This product should not be mixed with other commercial wastes for disposal.



elumen8