



QWM 1932

Fixed frequency UHF wireless system

863.0 + 864.0 MHz or 863.5 + 865.0 MHz

(Channel 70)

Due to continuous product development, please ensure that you have downloaded the latest instruction manual for this product from the Q-Audio website

Telephone: (+44) (0) 203 598 5164 • Email: info@q-audio.co.uk • Web: www.q-audio.co.uk

If this product is ever no longer functional please take it to a recycling plant for environmentally friendly disposal.

Due to continuous product development, specifications and appearance are subject to change. © Copyright Q-Audio. E&OE.



M A D E I N C H I N A

Thank you for purchasing this Q-Audio product, we are sure that it will serve you for many years to come.

To optimise the performance of this product, please read these operating instructions carefully to familiarise yourself with the basic operations of this unit. Please retain them for future reference. This unit has been tested at the factory before being shipped to you.

To prevent or reduce the risk of electrical shock or fire, do not expose the unit to rain or moisture. To prevent a fire hazard, do not expose the unit to any naked flame sources. Unplug this apparatus during lightning storms or if it is unlikely to be used for long periods of time.

When installing the unit, please ensure you leave enough space around the unit for ventilation. Slots and openings in the unit are provided for ventilation to ensure reliable operation of the product and to protect it from overheating. To prevent fire hazard, the openings should never be blocked or covered.

The unit is mains powered, always handle the power cable by the plug. Never pull out the plug by pulling on the cable. Never touch the power cable when your hands are wet as this could cause an electric shock. Do not tie a knot in the cable. The power cable should be placed such that it is not likely to be stepped on. A damaged power cable can cause a fire or give you an electrical shock. Check the power cord periodically, if you ever find that it is damaged, replace it before using the unit again. Contact your retailer for a replacement.

The voltage of the available power supply differs according to country or region. Be sure that the power supply voltage of the area where this unit is to be used meets the required written on the unit.

The lightning flash symbol inside a triangle is to alert the user to the presence of high voltage within the unit's enclosure that may be of sufficient power to constitute a risk of electrical shock to persons.

Caution: to prevent the risk of electric shock, do not attempt to open the unit. No user-serviceable parts inside. Refer all servicing to qualified service personnel.

The exclamation mark inside a triangle is intended to alert the user to the presence of important operating and maintenance instructions in the literature accompanying the appliance.

Select the installation location of your unit carefully. Avoid placing it in direct sunlight or locations subject to vibration and excessive dust. Do not use the unit where there are extremes in temperature (below 41°F / 5°C or exceeding 95°F / 35°C).

Unpacking and safety Please unpack your new product carefully. Your new product should reach you in perfect condition. Please check that no damage has occurred during transit. If any damage is found, do not operate your unit. Please contact the retailer you purchased it from immediately. If there is any damage to the mains cable do not use the device. Always disconnect the unit from the mains supply when carrying out any cleaning of the unit.

Manufacturer declarations



In compliance with the following requirements: **RoHS Directive (2011/65/EU)** and **WEEE Directive (2012/19/EU)**, and **Battery Directive (2006/66/EU)**. If this product is ever no longer functional please take it to a recycling plant for environmentally friendly disposal. Any supplied batteries can also be recycled.

CE declaration of conformity

RED Directive (2014/53/EU), EMC Directive (2014/30/EU), Low Voltage Directive (2014/35/EU).

The declarations are available on application from info@q-audio.co.uk

Before putting device into operation, please observe the respective country-specific regulations.

The **Q-Audio QWM 1932 HH** uses one of the following UHF frequencies sets:
 Option A: 863.0 and 864.0MHz or option B: 863.5 and 865.0MHz. A sticker indicating which frequency set your QWM1932 HH operates on is attached to the receiver.

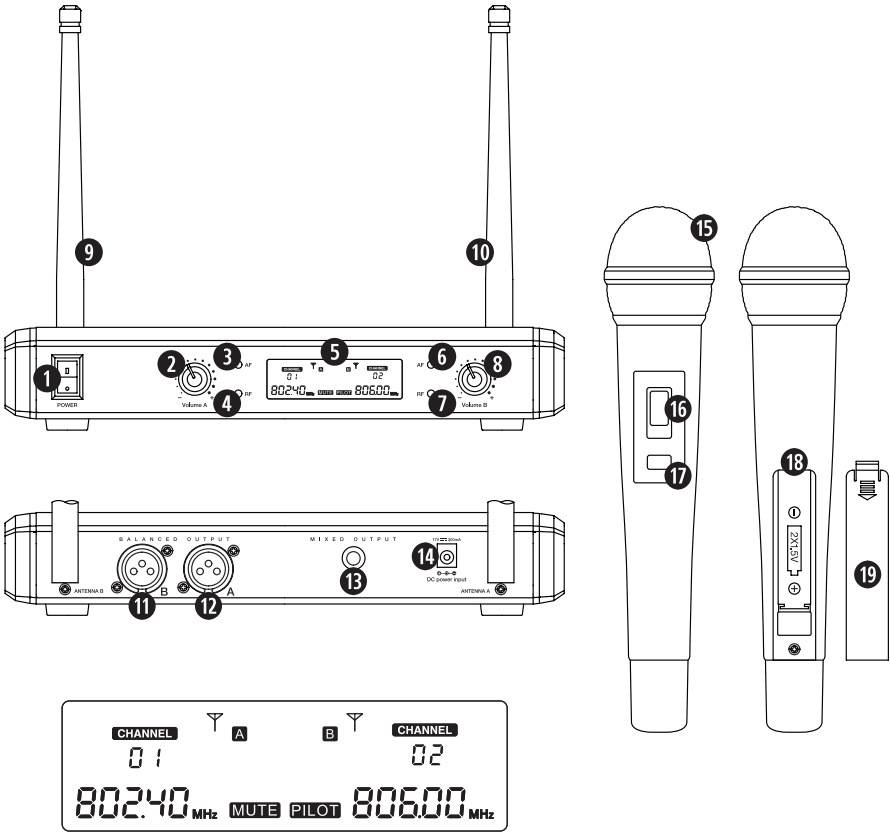

Receiver front panel

1. Power On/Off switch
2. Channel volume control for channel A
3. AF LED for channel A (audio frequency indicator)
4. RF LED for channel A (radio frequency indicator)
5. LCD display
6. AF LED for channel B (audio frequency indicator)
7. RF LED for channel B (radio frequency indicator)
8. Channel volume control for channel B
9. Adjustable antenna for channel A
10. Adjustable antenna for channel B

Handheld microphone transmitter

15. Microphone grille
16. Mic transmitter power On/Off switch
17. Mic status indicator
18. Battery compartment for AA 1.5V batteries
19. Battery socket cover

Receiver rear panel

11. Balanced XLR socket for audio output from channel B
12. Balanced XLR socket for audio output from channel A
13. Unbalanced 6.35mm jack socket for mixed audio output from both channels
14. DC power supply input socket

The **Q-Audio QWM 1932 BP** uses one of the following UHF frequencies sets:
 Option A: 863.0 and 864.0MHz **or** option B: 863.5 and 865.0MHz. A sticker indicating which frequency set your QWM1932 HH operates on is attached to the receiver.

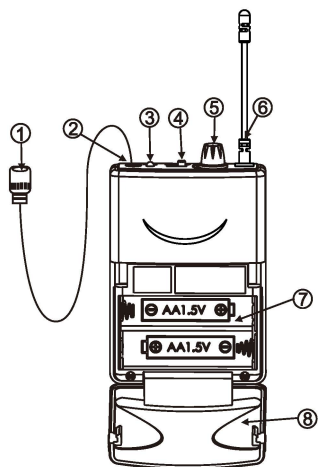

INCLUDED WITHIN THE 1932BP SYSTEM



1. HEADSET 2. GUITAR 3. LAVALIER

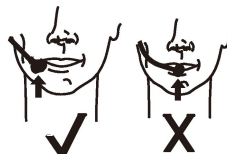

HEADSET POSITIONING



INSTRUMENT ADAPTER CABLE FOR GUITAR

Beltpack Transmitter

1. Input option (Lavalier, Headset or Guitar Cable)
2. Input socket
3. Power indicator
4. Power switch
5. Volume adjust
6. Antenna
7. Battery receptacle
8. Battery cover

Belt pack transmitter operation

1. Slide the ON/OFF switch to the ON position.
2. Check that the RF LED signal indicator is lit on your receiver to see if the wireless signal is being received.
3. If the signal indicator is lit, begin singing or speaking, this should now light up the AF LED on the receiver.
4. You can use the volume adjust knob to adjust the volume.
5. During the performance, slide the ON/OFF switch to the OFF position when the microphone is not being used.
6. When the performance is over, slide the ON/OFF switch to the OFF position to conserve battery power.

Operation

Before operating the system ensure that you have installed fresh batteries in the transmitters.

Receiver operation

1. Connect audio outputs for channel A and B to your mixer/amplifier, either two balanced XLR cables for dual output or a single unbalanced 6.35mm jack cable for mixed output of both channels.
2. Connect the DC power supply to the receiver and plug into an appropriate power outlet.

Handheld microphone transmitter operation

1. Slide the mic ON/OFF switch to the ON position.
2. Check that the RF LED signal indicator is lit on your receiver to see if the wireless signal is being received.
3. If the signal indicator is lit, begin singing or speaking, this should now light up the AF LED on the receiver.
4. During the performance, slide the ON/OFF switch to the OFF position when the microphone is not being used.
5. When the performance is over, slide the ON/OFF switch to the OFF position to conserve battery power.

If operating two Q-Audio QWM1932 HH kits together at the same time (i.e. two receivers and four microphones), each receiver will need to be running on a different frequency set to the other receiver (i.e. kit 1 frequencies: 863.0/864.0MHz and kit 2 frequencies: 863.5/865.0MHz). To avoid any interference between the two receivers, it is recommended that the receivers are placed at least 30cm apart.

Technical specifications

Fixed frequency UHF receiver

UHF frequencies sets:

Option A: 863.0 and 864.0MHz

Option B: 863.5 and 865.0MHz.

Balanced output sockets (3-pin XLR)

Unbalanced 6.35mm jack for mixed audio output

Twin adjustable antenna system

Automatically calibrated frequency stabilisation

Dynamic range: >90dB

Total harmonic distortion: <0.4%

Frequency response: 40Hz-15KHz \pm 3dB / S/N ratio: >95dB

Image and spurious rejection: >80dB

Border upon channel rejection: >80dB

Receiving sensitivity: 7dBuV

De-emphasis: 75uS

Receiver power supply DC 17V 300mA

Receiver dimensions: 270 x 175 x 50mm (WxDxH)

Receiver weight: 783g

Handheld microphones

Steel mesh grille

Transmitter power: 10mW

Modulation type: FM / Max deviation: \pm 20KHz

Spurious emission: >50dB

Mic battery voltage: 3V (2 x 1.5V AA batteries)

Continuous usage: 5 hours

Mic dimensions: 48 x 48 x 230mm (WxDxH)

Mic weight: 240g (each)