

# **EQUINOX**

## **MaxiPar Quad**

**User Manual**



**Order code: EQLED117**

### WARNING

#### FOR YOUR OWN SAFETY, PLEASE READ THIS USER MANUAL CAREFULLY BEFORE YOUR INITIAL START-UP!

- Before your initial start-up, please make sure that there is no damage caused during transportation.
- Should there be any damage, consult your dealer and do not use the equipment.
- To maintain the equipment in good working condition and to ensure safe operation, it is necessary for the user to follow the safety instructions and warning notes written in this manual.
- Please note that damages caused by user modifications to this equipment are not subject to warranty.



### IMPORTANT:

The manufacturer will not accept liability for any resulting damages caused by the non-observance of this manual or any unauthorised modification to the equipment.

- Never let the power cable come into contact with other cables. Handle the power cable and all mains voltage connections with particular caution!
- Never remove warning or informative labels from the unit.
- Do not open the equipment and do not modify the unit.
- Do not connect this equipment to a dimmer pack.
- Do not switch the equipment on and off in short intervals, as this will reduce the system's life.
- Only use the equipment indoors.
- Do not expose to flammable sources, liquids or gases.
- Always disconnect the power from the mains when equipment is not in use or before cleaning! Only handle the power-cable by the plug. Never pull out the plug by pulling the power-cable.
- Make sure that the available voltage is between 100~240V, 50/60Hz.
- Make sure that the power cable is never crimped or damaged. Check the equipment and the power cable periodically.
- If the equipment is dropped or damaged, disconnect the mains power supply immediately and have a qualified engineer inspect the equipment before operating again.
- If the equipment has been exposed to drastic temperature fluctuation (e.g. after transportation), do not connect power or switch it on immediately. The arising condensation might damage the equipment. Leave the equipment switched off until it has reached room temperature.
- If your product fails to function correctly, stop use immediately. Pack the unit securely (preferably in the original packing material), and return it to your Pro Light dealer for service.
- Only use fuses of same type and rating.
- Repairs, servicing and power connection must only be carried out by a qualified technician. THIS UNIT CONTAINS NO USER SERVICEABLE PARTS.
- WARRANTY: One year from date of purchase.

### OPERATING DETERMINATIONS

If this equipment is operated in any other way, than those described in this manual, the product may suffer damage and the warranty becomes void. Incorrect operation may lead to danger e.g: short-circuit, burns and electric shocks etc.

Do not endanger your own safety and the safety of others!

Incorrect installation or use can cause serious damage to people and/or property.

### MaxiPar Quad

This compact, slim profile par is designed for uplighting as well as stage lighting, and will bring deep, rich colours to any event or venue. It features 7 x 5W quad-colour RGBW LEDs which offer smooth colour mixing. Operational modes including DMX, auto, sound active and master/slave modes.

- 7 x 5W quad-colour LEDs (RGBW)
- Beam angle: 25°
- 1,554 Lux @ 2m (full on)
- DMX channels: 2/3/3/4 or 10 selectable
- Auto, sound active and master/slave modes
- 0-100% dimming and variable strobe
- 4 push button menu with LED display
- Bracket allows for multiple rigging or floor standing applications
- Rubber feet allow the panel to sit flat on the floor for uplighting
- Side entry XLR and power connections
- IEC power input/output
- 3-Pin XLR input/output
- Fan cooled
- Supplied with IR remote

Specifications	
Power consumption	35W
Power supply	100~240V, 50/60Hz
Fuse	F1A 250V
Dimensions	215 x 225 x 110mm
Weight	1.1kg
Order code	EQLED117

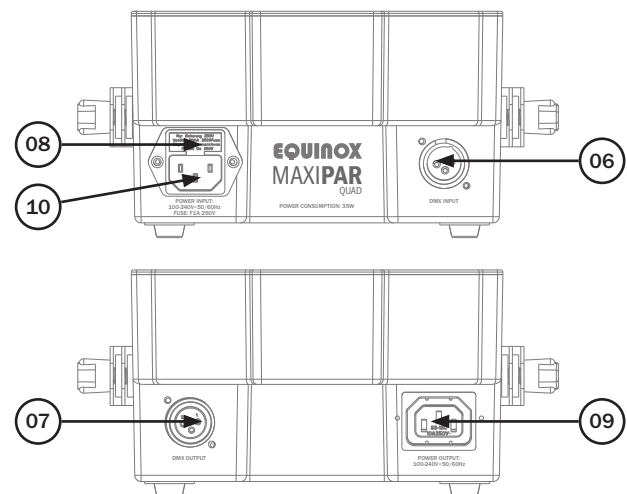
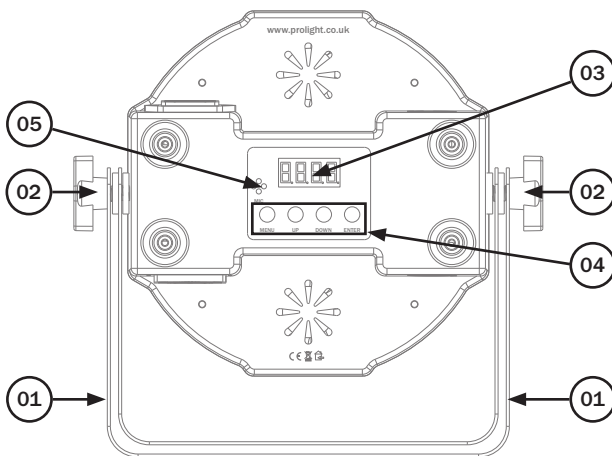
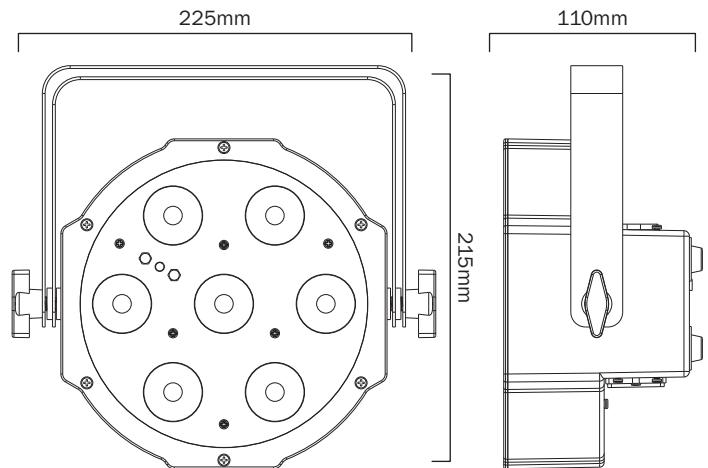
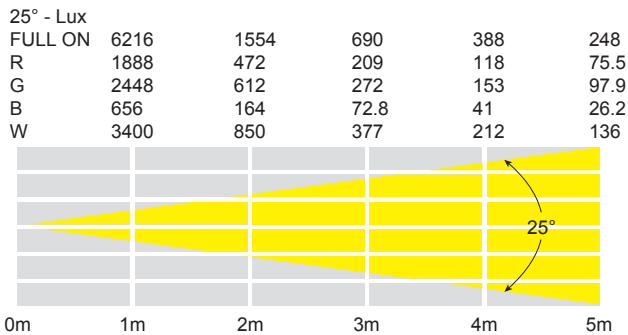

- 01 - Bracket
- 02 - Bracket knobs
- 03 - LED display
- 04 - Function buttons
- 05 - Microphone
- 06 - DMX input socket
- 07 - DMX output socket
- 08 - IEC power input socket
- 09 - IEC power output socket
- 10 - Fuse F1A 250V

In the box: **1 x fixture,**  
**1 x power cable &**  
**1 x user manual**

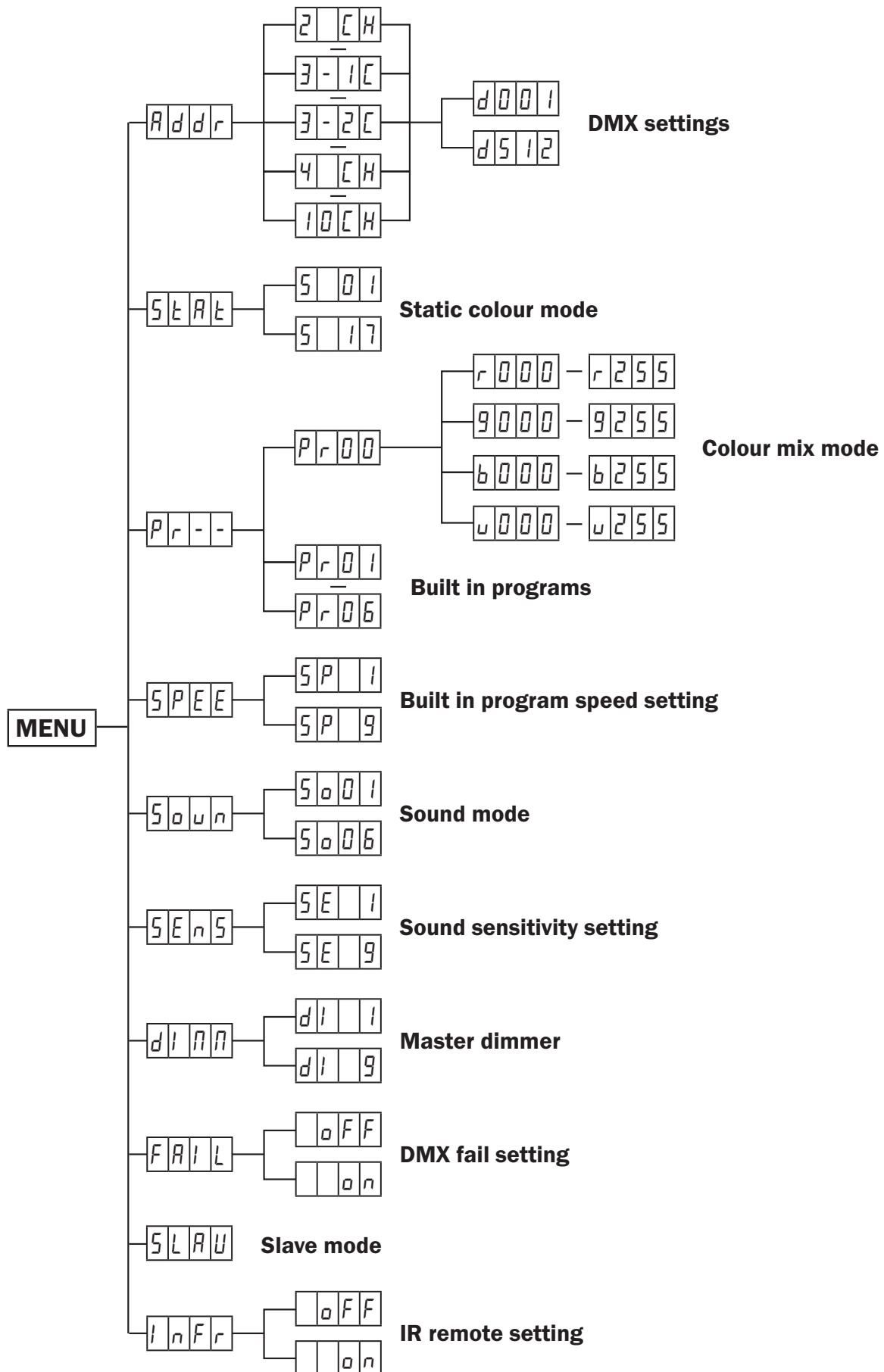

### DMX mode:

Operating in a DMX control mode environment gives the user the greatest flexibility when it comes to customising or creating a show. In this mode you will be able to control each individual trait of the fixture and each fixture independently.

To access the DMX mode, press the “**MENU**” button and use the “**UP**” and “**DOWN**” buttons to show *Addr* on the LED display. Now press the “**ENTER**” button and use the “**UP**” and “**DOWN**” buttons to choose one of the 2/3/3/4 or 10 DMX channel modes.

Press the “**ENTER**” button and use the “**UP**” and “**DOWN**” buttons to set the required DMX address. Press the “**ENTER**” button to confirm the setting.

To exit out of any of the above options, press the “**MENU**” button.

### 2 channel mode:

Channel	Value	Function
CH1	000-255	Master dimmer (0-100%)
CH2	000-009	No function
	010-019	Red
	020-029	Green
	030-039	Blue
	040-049	White
	050-059	Yellow
	060-069	Magenta
	070-079	Cyan
	080-089	Dark Orange
	090-099	Lime Green
	100-109	Salmon Pink
	110-119	Turquoise
	120-129	Mint Green
	130-139	Orange
	140-149	Lavender
	150-159	Light Blue
	160-169	Dark Blue
170-255	Pink	

### 3-2 channel mode:

Channel	Value	Function
CH1	000-255	Red dimmer (0-100%)
CH2	000-255	Green dimmer (0-100%)
CH3	000-255	Blue dimmer (0-100%)

### 3-1 channel mode:

Channel	Value	Function
CH1	000-009	No function
	010-050	Program 1 (4 colour fade in/out)
	051-091	Program 2 (7 colour fade in/out)
	092-132	Program 3 (colour fade)
	133-173	Program 4 (7 colour fade in/out + colour fade)
	174-214	Program 5 (4 colour change)
	215-255	Program 6 (7 colour change)
	CH2	000-009
010-050		Sound 1 (4 colour fade in/out)
051-091		Sound 2 (7 colour fade in/out)
092-132		Sound 3 (colour fade)
133-173		Sound 4 (7 colour fade in/out + colour fade)
174-214		Sound 5 (4 colour change)
215-255		Sound 6 (7 colour change)
CH3	000-255	Speed of Programs 1-6 (slow-fast) Sensitivity of Sound 1-6 (low-high)

### 4 channel mode:

Channel	Value	Function
CH1	000-255	Red dimmer (0-100%)
CH2	000-255	Green dimmer (0-100%)
CH3	000-255	Blue dimmer (0-100%)
CH4	000-255	White dimmer (0-100%)

### 10 channel mode:

Channel	Value	Function
CH1	000-255	Master dimmer (0-100%)
CH2	000	No function
	001-255	Strobe (slow-fast)
CH3	000-255	Red dimmer (0-100%)
CH4	000-255	Green dimmer (0-100%)
CH5	000-255	Blue dimmer (0-100%)
CH6	000-255	White dimmer (0-100%)
CH7	000-009	No function
	010-019	Red
	020-029	Green
	030-039	Blue
	040-049	White
	050-059	Yellow
	060-069	Magenta
	070-079	Cyan
	080-089	Dark Orange
	090-099	Lime Green
	100-109	Salmon Pink
	110-119	Turquoise
	120-129	Mint Green
	130-139	Orange
	140-149	Lavender
	150-159	Light Blue
	160-169	Dark Blue
170-255	Pink	

Channel	Value	Function
CH8	000-009	No function
	010-050	Program 1 (4 colour fade in/out)
	051-091	Program 2 (7 colour fade in/out)
	092-132	Program 3 (colour fade)
	133-173	Program 4 (7 colour fade in/out + colour fade)
	174-214	Program 5 (4 colour change)
	215-255	Program 6 (7 colour change)
CH9	000-009	No function
	010-050	Sound 1 (4 colour fade in/out)
	051-091	Sound 2 (7 colour fade in/out)
	092-132	Sound 3 (colour fade)
	133-173	Sound 4 (7 colour fade in/out + colour fade)
	174-214	Sound 5 (4 colour change)
215-255	Sound 6 (7 colour change)	
CH10	000-255	Speed of Programs 1-6 (slow-fast) Sensitivity of Sound 1-6 (low-high)

### Static colour mode:

To access the static colour mode press “MENU” until *SEAL* shows on the LED display.

Now press the “ENTER” button and use the “UP” and “DOWN” buttons to select the colour required between *5 01* ~ *5 17*. Press the “ENTER” button to confirm.

To exit out of any of the above options, press the “MENU” button.

*5 01* - Red

*5 07* - Cyan

*5 13* - Orange

*5 02* - Green

*5 08* - Dark Orange

*5 14* - Lavender

*5 03* - Blue

*5 09* - Lime Green

*5 15* - Light Blue

*5 04* - White

*5 10* - Salmon Pink

*5 16* - Dark Blue

*5 05* - Yellow

*5 11* - Turquoise

*5 17* - Pink

*5 06* - Magenta

*5 12* - Mint Green

### Colour mix mode:

In this mode you can set the fixture to any colour and any brightness.

To access the colour mix mode press “MENU” until the display shows *Pr - -* on the LED display.

Press the “ENTER” button and use the “UP” and “DOWN” buttons to select *Pr 00*.

Press the “ENTER” button to show *r - - -* with 3 digits after on the LED display.

Press the “ENTER” button to confirm.

The *r* represents red, *G* = green, *b* = blue and *w* = white.

The 3 digits after are the brightness setting from *000 ~ 255*.

### **For example:**

If you set *r*, *G*, *b* and *w* all to zero, your unit will have no LEDs lit up (blackout).

If you set *r 000* to *r 255* and *G*, *b* and *w* to zero, your unit will show only red LEDs.

Press the “ENTER” button to confirm the setting and move to the next colour.

To exit out of any of the above options, press the “MENU” button.

### Built-in program mode:

To access built-in program mode press “MENU” until the display shows *Pr - -* on the LED display.

Press the “ENTER” button and use the “UP” and “DOWN” buttons to select between *Pr 01 ~ Pr 06*.

Press the “ENTER” button to confirm.

To exit out of any of the above options, press the “MENU” button.

<i>Pr 01</i> - 4 colour fade in/out	<i>Pr 03</i> - Colour fade	<i>Pr 05</i> - 4 colour change
<i>Pr 02</i> - 7 colour fade in/out	<i>Pr 04</i> - 7 colour fade in/out + colour fade	<i>Pr 06</i> - 7 colour change

### Built-in program speed setting:

To access built-in program speed setting press “MENU” until the display shows *SPEE* on the LED display. Press the “ENTER” button and use the “UP” and “DOWN” buttons to select between *SP 1* (slow) ~ *SP 9* (fast).

Press the “ENTER” button to confirm.

To exit out of any of the above options, press the “MENU” button.

### Sound mode:

To access sound mode press “MENU” until the display shows *SOUN* on the LED display.

Press the “ENTER” button and use the “UP” and “DOWN” buttons to select between *So 01 ~ So 06*.

Press the “ENTER” button to confirm.

To exit out of any of the above options, press the “MENU” button.

<i>So 01</i> - 4 colour fade in/out	<i>So 03</i> - Colour fade	<i>So 05</i> - 4 colour change
<i>So 02</i> - 7 colour fade in/out	<i>So 04</i> - 7 colour fade in/out + colour fade	<i>So 06</i> - 7 colour change

### Sound sensitivity setting:

To access sound sensitivity setting press “MENU” until the display shows *SEN5* on the LED display. Press the “ENTER” button and use the “UP” and “DOWN” buttons to select between *SE 1* (low) ~ *SE 9* (high).

Press the “ENTER” button to confirm.

To exit out of any of the above options, press the “MENU” button.

### Master dimmer setting:

To access master dimmer setting press “MENU” until the display shows *dim* on the LED display.

Press the “ENTER” button and use the “UP” and “DOWN” buttons to select between

*dim 1* (low brightness) ~ *dim 9* (high brightness). Press the “ENTER” button to confirm.

To exit out of any of the above options, press the “MENU” button.

### DMX fail setting:

To access DMX fail setting press “MENU” until the display shows *FAIL* on the LED display.

Press the “ENTER” button and use the “UP” and “DOWN” buttons to select between

*on* (when no DMX signal unit goes into last used program or sound mode) ~

*off* (when no DMX signal unit goes into blackout).

Press the “ENTER” button to confirm.

To exit out of any of the above options, press the “MENU” button.

### Master/slave mode:

The default setting for this fixture is Master. Set the master unit in one of the built-in programs, sound modes, colour mix mode or static colour mode.

To set the slave unit, press the “MENU” button on the front of the master unit to show *SLAVE* on the LED display. The unit is now in Slave mode.

To exit out of any of the above options, press the “MENU” button.

Please ensure that all slave units are set to the same DMX channel mode as the master unit.

### IR remote setting:

To access IR remote setting press “MENU” until the display shows *IR* on the LED display.

Press the “ENTER” button and use the “UP” and “DOWN” buttons to select between

*on* (IR receiver on) ~ *off* (IR receiver off).

Press the “ENTER” button to confirm.

To exit out of any of the above options, press the “MENU” button.



### IR remote functions:

- 01 - Sets the unit into blackout off/on (LED on/off)
- 02 - Activates the built-in programs, use the '+' and '-' buttons to select the auto mode. Pressing the 'Speed' button followed by the '+' and '-' buttons will then allow the auto mode speed to be adjusted
- 03 - Activates the sound modes, use the '+' and '-' buttons to select the sound mode. Pressing the 'Sensitivity' button followed by the '+' and '-' buttons will then allow the sound sensitivity to be adjusted
- 04 - Activates the strobe, use the '+' and '-' buttons to adjust the strobe speed
- 05 - Sets the auto mode speed. Press this button followed by the '+' and '-' buttons to adjust the program speed
- 06 - Sets the sound mode sensitivity. Press this button followed by the '+' and '-' buttons to adjust the sound sensitivity
- 07 - Activates the DMX mode  
Please note: the DMX address and channel must be preset in the menu
- 08 - Activates the static colour/manual modes, use the '+' and '-' buttons to select a colour from the pre-programmed static colours or use the 'R', 'G', 'B' or 'W' buttons to create a manual colour. Pressing the 'Fade/unit' button allows the chosen colour to enter the fade program
- 09 - Activates a fade in/out on the manual colour selection
- 10 - Manual colour selection  
A - Red      B - Green      C - Blue      D - White
- 11 - Adjusts the auto mode, sound mode, speed, sound sensitivity, strobe speed and static colour/manual colour modes
- 12 - Sets the brightness of auto, sound, static colour and manual modes (1 - low brightness, 9 - high brightness)

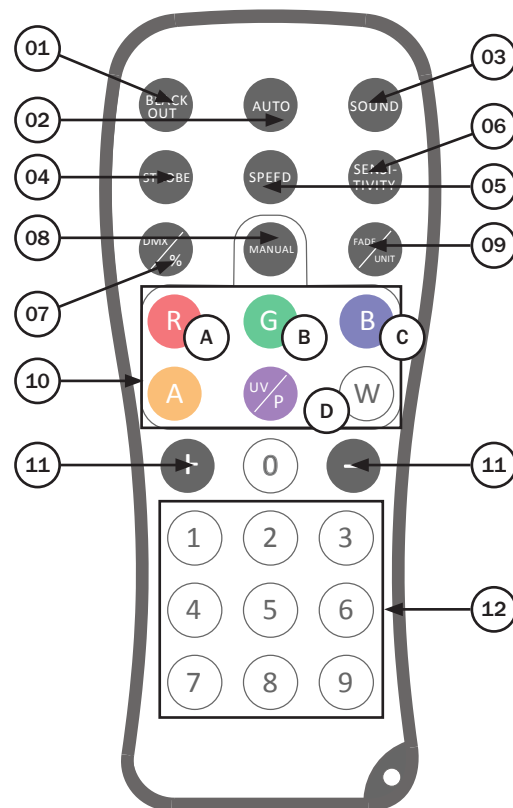

### Setting the DMX address:

The DMX mode enables the use of a universal DMX controller. Each fixture requires a “start address” from 1- 512. A fixture requiring one or more channels for control begins to read the data on the channel indicated by the start address. For example, a fixture that occupies or uses 7 channels of DMX and was addressed to start on DMX channel 100, would read data from channels: 100, 101, 102, 103, 104, 105 and 106. Choose a start address so that the channels used do not overlap. E.g. the next unit in the chain starts at 107.

### DMX 512:

DMX (Digital Multiplex) is a universal protocol used as a form of communication between intelligent fixtures and controllers. A DMX controller sends DMX data instructions from the controller to the fixture. DMX data is sent as serial data that travels from fixture to fixture via the DATA “IN” and DATA “OUT” XLR terminals located on all DMX fixtures (most controllers only have a data “out” terminal).

### DMX linking:

DMX is a language allowing all makes and models of different manufactures to be linked together and operate from a single controller, as long as all fixtures and the controller are DMX compliant. To ensure proper DMX data transmission, when using several DMX fixtures try to use the shortest cable path possible. The order in which fixtures are connected in a DMX line does not influence the DMX addressing. For example; a fixture assigned to a DMX address of 1 may be placed anywhere in a DMX line, at the beginning, at the end, or anywhere in the middle. When a fixture is assigned a DMX address of 1, the DMX controller knows to send DATA assigned to address 1 to that unit, no matter where it is located in the DMX chain.

### DATA cable (DMX cable) requirements (for DMX operation):

This fixture can be controlled via DMX-512 protocol. The DMX address is set on the back of the unit. Your unit requires either a standard 3-pin or 5-pin XLR connector for data input/output, see images below.

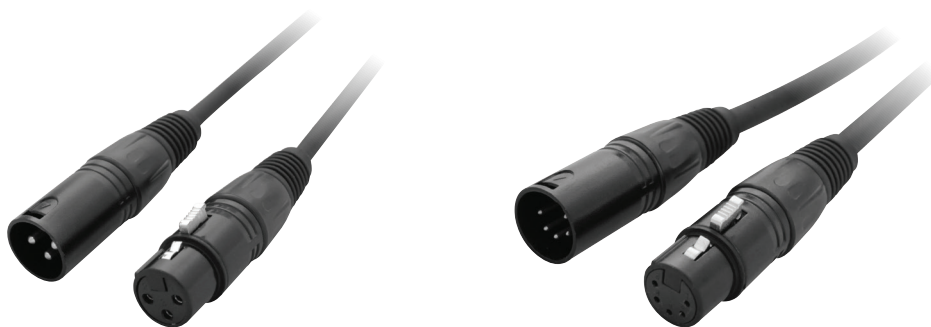

Further DMX cables can be purchased from all good sound and lighting suppliers or Prolight Concepts dealers.

Please quote:	3-Pin:	<b>CABL10 – 2m</b>	<b>CABL11 – 5m</b>	<b>CABL12 – 10m</b>
	5-Pin:	<b>CABL185 – 2m</b>	<b>CABL187 – 5m</b>	<b>CABL188 – 10m</b>

Also remember that DMX cable must be daisy chained and cannot be split.

**Notice:**

Be sure to follow the diagrams below when making your own cables. Do not connect the cables shield conductor to the ground lug or allow the shield conductor to come in contact with the XLRs outer casing. Grounding the shield could cause a short circuit and erratic behaviour.

Pin Configuration	
3-Pin	5-Pin
	Pin 1 - Ground
	Pin 2 - Negative
	Pin 3 - Positive
-	Pin 4 - N/C
-	Pin 5 - N/C

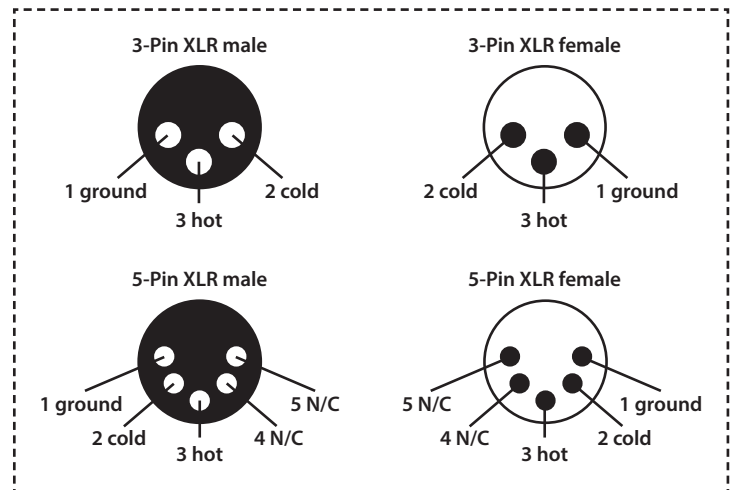
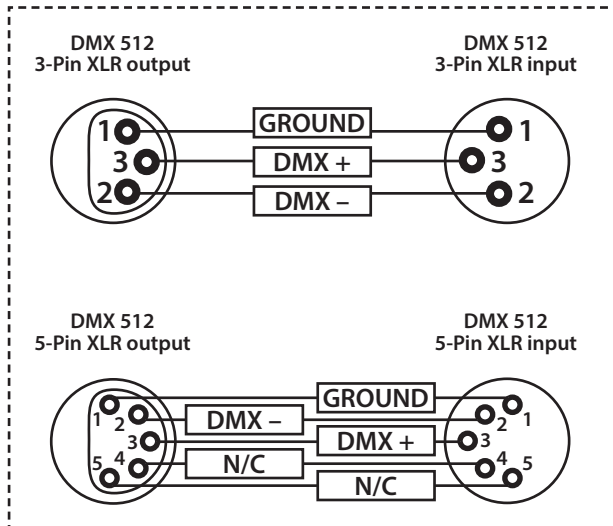

**Line termination:**

When longer runs of cable are used, you may need to use a terminator on the last unit to avoid erratic behaviour.

**Using a cable terminator will decrease the possibilities of erratic behaviour.**

(3-pin - Order ref: CABL90,  
5-pin - Order ref: CABL89)

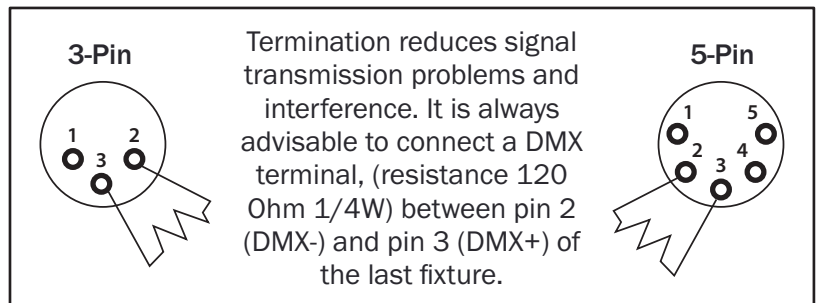

**5-pin XLR DMX connectors:**

Some manufactures use 5-pin XLR connectors for data transmission in place of 3-pin. 5-pin XLR fixtures may be implemented in a 3-pin XLR DMX line. When inserting standard 5-pin XLR connectors in to a 3-pin line a cable adaptor must be used. The diagram below details the correct cable conversion.

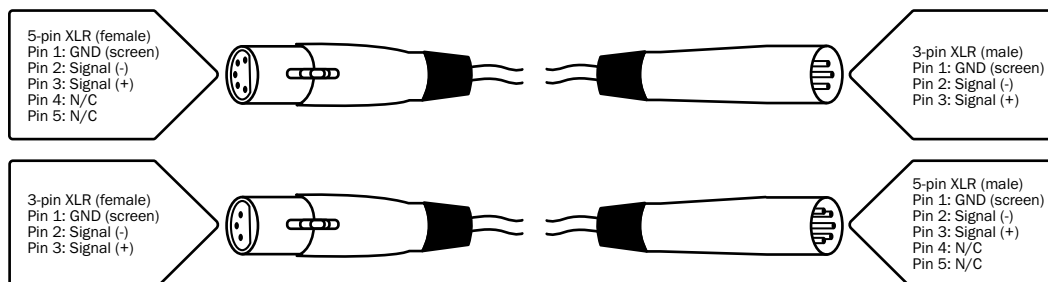

### Power linking:

This fixture provides power linking via the power output on the rear allowing multiple units to be connected together. The maximum number of fixtures that can be connected is 24 fixtures @ 240V or 12 fixtures @ 120V (including the first fixture). After the maximum number of fixtures are connected a new power run will need to be started.

Please note: Caution should be used when power linking other fixtures to the MaxiPar Quad as the power consumption of other fixtures will vary. Fixtures fitted with lamps often require 2/3 times more current on startup, these may require their own power source.

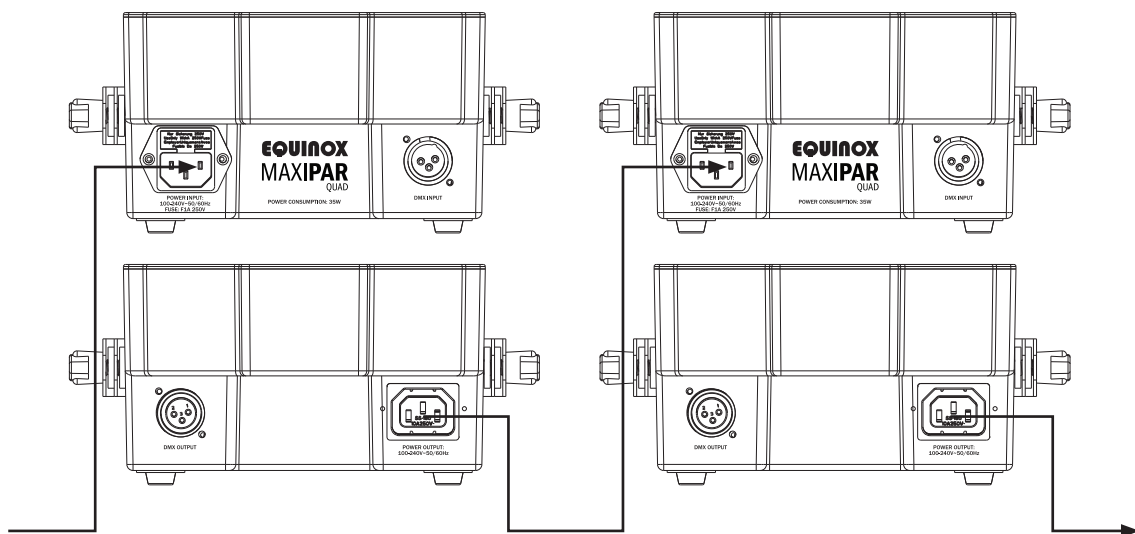



### ***Correct Disposal of this Product (Waste Electrical & Electronic Equipment)***

**(Applicable in the European Union and other European countries  
with separate collection systems)**

This marking shown on the product or its literature, indicates that it should not be disposed of with other household wastes at the end of its working life. To prevent possible harm to the environment or human health from uncontrolled waste disposal, please separate this from other types of wastes and recycle it responsibly to promote the sustainable reuse of material resources.

Household users should contact either the retailer where they purchased this product, or their local government office, for details of where and how they can take this item for environmentally safe recycling.

Business users should contact their supplier and check the terms and conditions of the purchase contract. This product should not be mixed with other commercial wastes for disposal.







# EQUINOX