

elumen8

Endura 18Q5 RGBW Exterior Fixture User Manual



Order code: ELUM450

WARNING

FOR YOUR OWN SAFETY, PLEASE READ THIS USER MANUAL CAREFULLY BEFORE YOUR INITIAL START-UP!

- Before your initial start-up, please make sure that there is no damage caused during transportation.
- Should there be any damage, consult your dealer and do not use the equipment.
- To maintain the equipment in good working condition and to ensure safe operation, it is necessary for the user to follow the safety instructions and warning notes written in this manual.
- Please note that damages caused by user modifications to this equipment are not subject to warranty.



IMPORTANT:

The manufacturer will not accept liability for any resulting damages caused by the non-observance of this manual or any unauthorised modification to the equipment.

- Never let the power cable come into contact with other cables. Handle the power cable and all mains voltage connections with particular caution!
- Never remove warning or informative labels from the unit.
- Do not open the equipment and do not modify the unit.
- Do not connect this equipment to a dimmer pack.
- Do not switch the equipment on and off in short intervals, as this will reduce the system's life.
- Do not expose to flammable sources, liquids or gases.
- Always disconnect the power from the mains when equipment is not in use or before cleaning! Only handle the power-cable by the plug. Never pull out the plug by pulling the power-cable.
- Make sure that the available mains supply voltage is between 100~240V AC, 50/60Hz.
- Make sure that the power cable is never crimped or damaged. Check the equipment and the power cable periodically.
- If the equipment is dropped or damaged, disconnect the mains power supply immediately and have a qualified engineer inspect the equipment before operating again.
- If your product fails to function correctly, stop use immediately. Pack the unit securely (preferably in the original packing material), and return it to your Pro Light dealer for service.
- Only use fuses of same type and rating.
- Repairs, servicing and power connection must only be carried out by a qualified technician. **THIS UNIT CONTAINS NO USER SERVICEABLE PARTS.**
- This lighting fixture is for professional use only - it is not designed for or suitable for household use. The product must be installed by a qualified technician in accordance with local territory regulations. The safety of the installation is the responsibility of the installer. The fixture presents risks of severe injury or death due to fire hazards, electric shock and falls.
- Warning! Risk Group 2 LED product according to EN 62471. Do not view the light output with optical instruments or any device that may concentrate the beam.
- **WARRANTY:** Two years from date of purchase.

OPERATING DETERMINATIONS

If this equipment is operated in any other way, than those described in this manual, the product may suffer damage and the warranty becomes void. Incorrect operation may lead to danger e.g: short-circuit, burns and electric shocks etc.

Do not endanger your own safety and the safety of others!

Incorrect installation or use can cause serious damage to people and/or property.

Endura 18Q5 RGBW Exterior Fixture

The Endura series are heavy-duty, rental ready IP rated pars made for the most demanding of applications. With flicker-free operation, thanks to a 3,600Hz refresh rate, and a multitude of colour and output options the series is perfectly suited for use in concert, TV and outdoor applications. The fixture can be controlled via DMX and provides a variety of colour macro, change, fade and strobe functions with 4 selectable dimmer curves. The fixture it is also capable of master/slave operation and is accessible via a 4 button backlit display with menu lock to prevent unauthorised setting changes. The robust IP65 rated housing features TRUE1 and 5-pin DMX inputs and outputs to facilitate a problem-free connection.

- 18 x 5W quad-colour LEDs (RGBW)
- Beam angle: 20°
- 4,126 Lux @ 2m (full on)
- 3.6kHz refresh rate
- DMX channels: 1/4/8 or 9 selectable
- Static colour, colour change, colour fade and master/slave modes
- 0 - 100% 8 or 16 bit dimming and variable strobe
- Bracket allows for multiple rigging or floor standing applications
- 4 button backlit menu with LCD display
- PowerCON TRUE1 input/output
- IP rated 5-Pin XLR input/output
- Convection cooled
- 30mm snoot included

| Specifications | Endura 18Q5 RGBW |
|-------------------|-------------------|
| Power consumption | 90W |
| Power supply | 100~240V, 50/60Hz |
| Fuse | T2A 250V |
| IP rating | IP65 |
| Dimensions | 310 x 280 x 195mm |
| Weight | 4.8kg |
| Order codes | ELUM450 |



| 20° - Lux | | | | | |
|-----------|-------|------|------|------|------|
| FULL ON | 16500 | 4126 | 1840 | 1030 | 661 |
| R | 3080 | 770 | 342 | 193 | 123 |
| G | 6440 | 1609 | 716 | 403 | 258 |
| B | 840 | 210 | 93.3 | 52.5 | 33.6 |
| W | 5640 | 1410 | 627 | 353 | 226 |

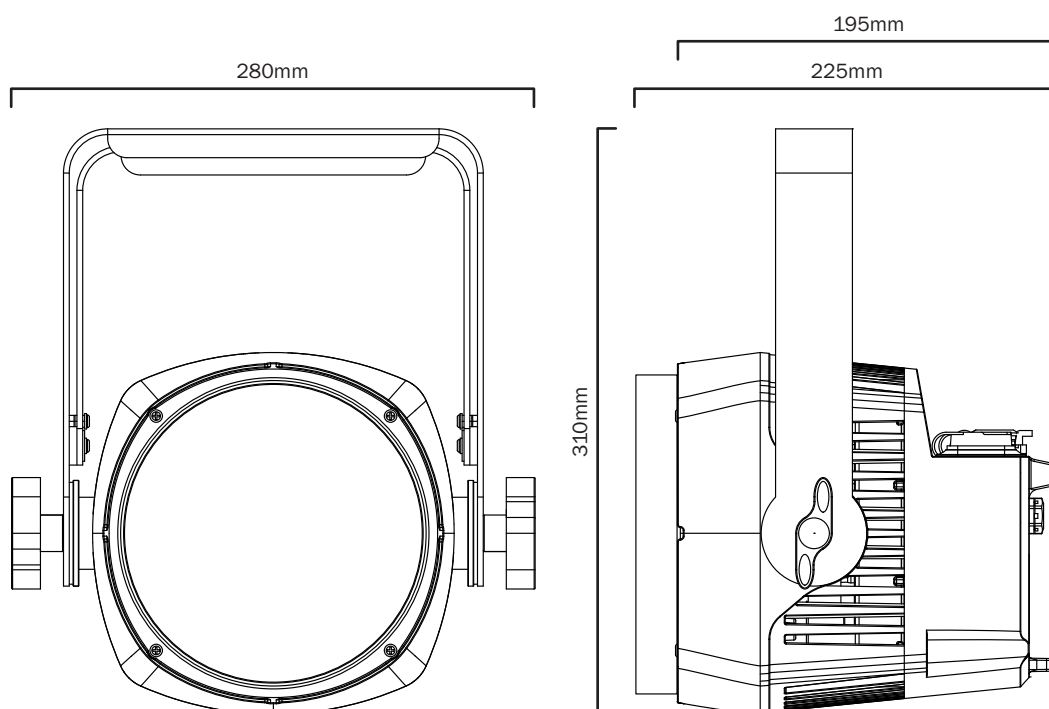
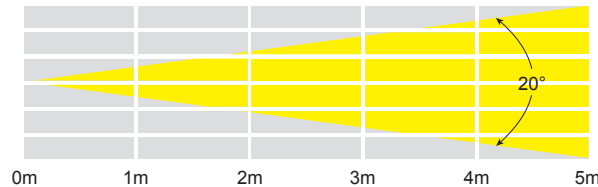

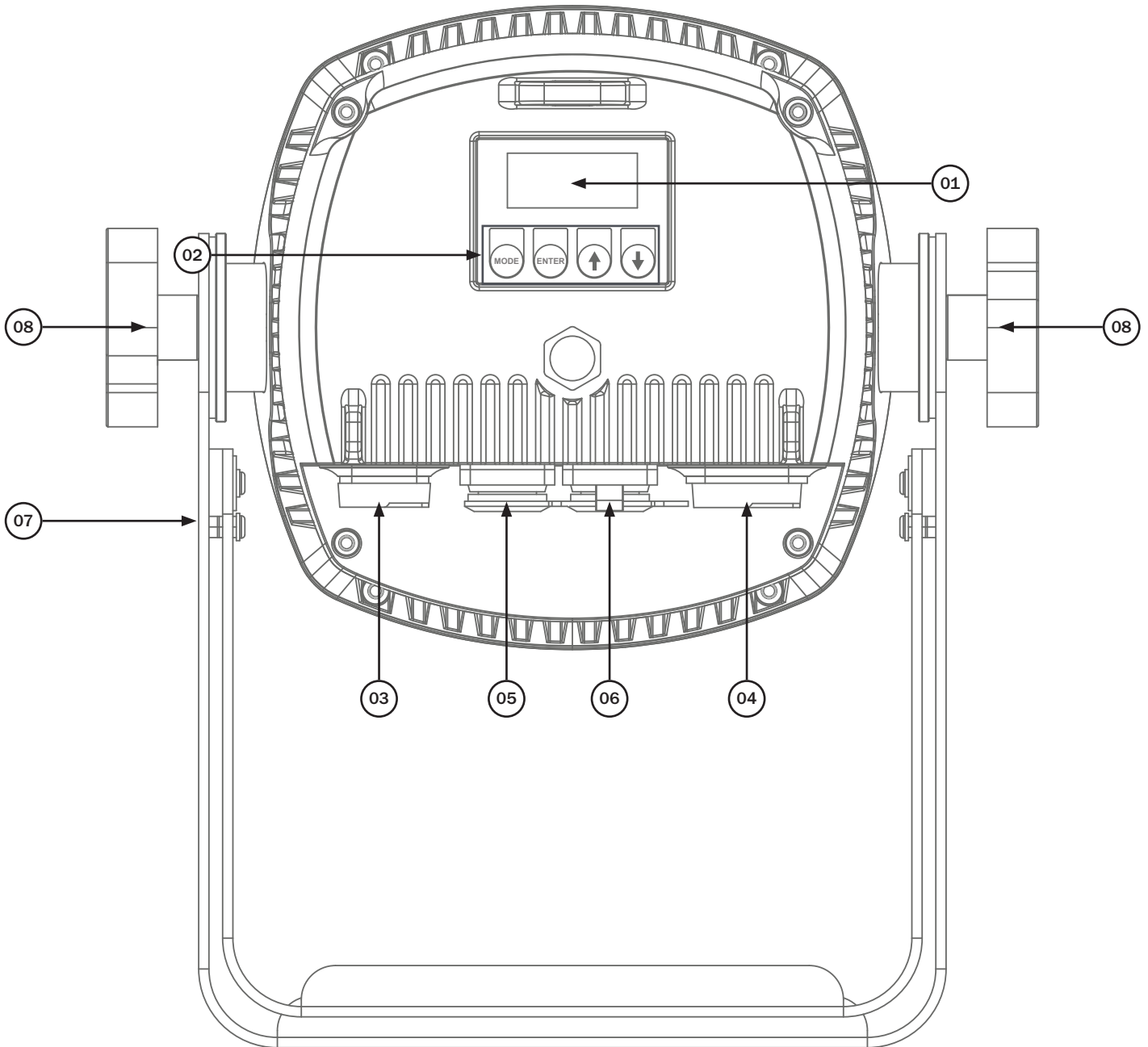

- | | |
|----------------------------|--------------------------------------|
| 01 - LCD display | 05 - IP rated 5-Pin DMX input |
| 02 - Function buttons | 06 - IP rated 5-Pin DMX output |
| 03 - PowerCON TRUE1 input | 07 - Hanging bracket |
| 04 - PowerCON TRUE1 output | 08 - Hanging bracket adjustable knob |

In the box: **1 x fixture**
1 x PowerCON TRUE1 cable
& 1 x user manual

Fuse: The Endura 18Q5 RGBW is fitted with an internal mains (line) fuse. The fuse must only be changed by qualified personnel. Before opening the fixtures housing or changing the fuse, the fixture must be disconnected and isolated from the mains supply. Replacement cartridge fuses must be of the same type and rating (20mm Glass T2A 250V). When closing the fixture please ensure the seal is correctly positioned and free from damage to ensure the fixture is water tight and to prevent water ingress.

IMPORTANT! PLEASE NOTE: The LCD display for this fixture has a locking function which can be enabled via the menu where after 20 seconds of inactivity it will lock. To unlock the menu press the buttons in the following sequence “UP”, “DOWN”, “UP”, “DOWN”, “ENTER”.

| Main Menu | Sub Menu | Options/Values (Default Settings in BOLD) | | Description |
|------------|-------------------------|---|------------------|-----------------------------|
| DMX Addr | | 001-512 | | DMX Address Setting |
| DMX Mode | | 01CH (01 channel mode) 04CH (04 channel mode) 08CH (08 channel mode) 09CH (09 channel mode) | | DMX Channel Setting |
| Slave Mode | | | | Slave Mode |
| DimMode | | LED HALOGEN | | Dimming Curves Mode Setting |
| DimCurve | | Linear Square I-Square S-Curve | | Dimming Curves Setting |
| 01.STATIC | 01.STATIC CL | R (Red) G (Green) B (Blue) W (White) RG (Yellow) GB (Cyan) RB (Magenta) RGBW (Full on) BLAC (Blackout) | F000-F255 | Static Colour Mode |
| | 02.FADE | SP00-SP99 | F000-F255 | Colour Fade Mode |
| | 03.CHANG | SP00-SP99 | F000-F255 | Colour Change Mode |
| Manual | | R: G: B: W: STR: Dim: | 000-255 | Manual Dimming Mode |
| Macros | | 00-63 | | Colour Macros |
| NO DMX | | Hold Blackout | | DMX Fail Setting |
| Temp. | | --- °C --- °F | | Fixture Temperature |
| WhiteBal | | R: G: B: W: | 000-255 | White Balance Setting |
| AutoLock | | OFF ON | | Auto Lock Menu Setting |
| Op.Time | | --- | | Fixture Run Time |
| DFSE | | OFF ON | | Default Factory Settings |

1 channel mode (8 bit):

| Channel | Value | Function |
|---------|---------|---------------------------|
| 1 | 000-127 | Colour macros |
| | 128-191 | Colour change (slow-fast) |
| | 192-255 | Colour fade (slow-fast) |

4 channel mode (8 bit):

| Channel | Value | Function |
|---------|---------|-----------------------|
| 1 | 000-255 | Red dimmer (0-100%) |
| 2 | 000-255 | Green dimmer (0-100%) |
| 3 | 000-255 | Blue dimmer (0-100%) |
| 4 | 000-255 | White dimmer (0-100%) |

8 channel mode (8 bit):

| Channel | Value | Function | |
|---------|---------|---------------------------|------------------------|
| 1 | 000-255 | Red dimmer (0-100%) | |
| 2 | 000-255 | Green dimmer (0-100%) | |
| 3 | 000-255 | Blue dimmer (0-100%) | |
| 4 | 000-255 | White dimmer (0-100%) | |
| 5 | 000-255 | Strobe (slow-fast) | |
| 6 | 000-255 | Master dimmer (0-100%) | |
| 7 | 000-004 | No function | |
| | 005-125 | Colour change (slow-fast) | |
| | 126-255 | Colour fade (slow-fast) | |
| 8 | 000-045 | Linear | Halogen Dimming Curves |
| | 046-075 | Square | |
| | 076-105 | Inverse Square | |
| | 106-135 | S-Curve | |
| | 136-165 | Linear | LED Dimming Curves |
| | 166-195 | Square | |
| | 196-225 | Inverse Square | |
| | 226-255 | S-Curve | |

9 channel mode (16 bit):

| Channel | Value | Function | |
|---------|---------|---------------------------|------------------------|
| 1 | 000-255 | Red dimmer (0-100%) | |
| 2 | 000-255 | Green dimmer (0-100%) | |
| 3 | 000-255 | Blue dimmer (0-100%) | |
| 4 | 000-255 | White dimmer (0-100%) | |
| 5 | 000-255 | Strobe (slow-fast) | |
| 6 | 000-255 | Master dimmer (0-100%) | |
| 7 | 000-255 | Dimmer fine | |
| 8 | 000-004 | No function | |
| | 005-125 | Colour change (slow-fast) | |
| | 126-255 | Colour fade (slow-fast) | |
| 9 | 000-045 | Linear | Halogen Dimming Curves |
| | 046-075 | Square | |
| | 076-105 | Inverse Square | |
| | 106-135 | S-Curve | |
| | 136-165 | Linear | LED Dimming Curves |
| | 166-195 | Square | |
| | 196-225 | Inverse Square | |
| | 226-255 | S-Curve | |

Setting the DMX address:

The DMX mode enables the use of a universal DMX controller. Each fixture requires a “start address” from 1- 511. A fixture requiring one or more channels for control begins to read the data on the channel indicated by the start address. For example, a fixture that occupies or uses 7 channels of DMX and was addressed to start on DMX channel 100, would read data from channels: 100,101,102,103,104,105 and 106. Choose a start address so that the channels used do not overlap. E.g. the next unit in the chain starts at 107.

DMX 512:

DMX (Digital Multiplex) is a universal protocol used as a form of communication between intelligent fixtures and controllers. A DMX controller sends DMX data instructions from the controller to the fixture. DMX data is sent as serial data that travels from fixture to fixture via the DATA “IN” and DATA “OUT” XLR terminals located on all DMX fixtures (most controllers only have a data “out” terminal).

DMX linking:

DMX is a language allowing all makes and models of different manufactures to be linked together and operate from a single controller, as long as all fixtures and the controller are DMX compliant. To ensure proper DMX data transmission, when using several DMX fixtures try to use the shortest cable path possible. The order in which fixtures are connected in a DMX line does not influence the DMX addressing. For example; a fixture assigned to a DMX address of 1 may be placed anywhere in a DMX line, at the beginning, at the end, or anywhere in the middle. When a fixture is assigned a DMX address of 1, the DMX controller knows to send DATA assigned to address 1 to that unit, no matter where it is located in the DMX chain.

DATA cable (DMX cable) requirements (for DMX operation):

This fixture can be controlled via DMX-512 protocol. The DMX address is set on the back of the unit. Your unit and your DMX controller require a standard 3-pin XLR connector for data input/output, see image below.



Further DMX cables can be purchased from all good sound and lighting suppliers or Pro Light Concepts dealers.

Please quote:

CABL10 – 2m

CABL11 – 5m

CABL12 – 10m

Note: DMX cable must be daisy chained and cannot be split.

Notice:

Be sure to follow the diagrams below when making your own cables. Do not connect the cables shield conductor to the ground lug or allow the shield conductor to come in contact with the XLRs outer casing. Grounding the shield could cause a short circuit and erratic behaviour.

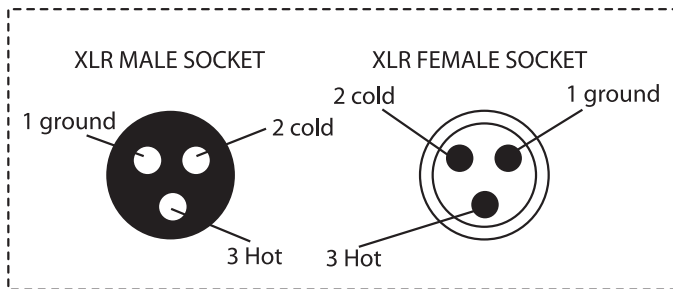
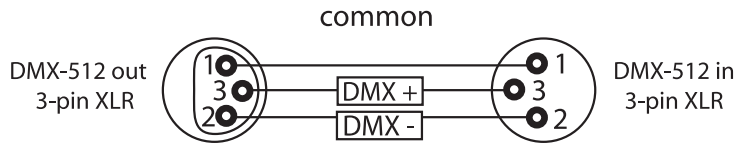

| XLR Pin Configuration |
|-----------------------|
| Pin 1 = Ground |
| Pin 2 = Negative |
| Pin 3 = Postive |

Special note:

Line termination:

When longer runs of cable are used, you may need to use a terminator on the last unit to avoid erratic behaviour.

Using a cable terminator will decrease the possibilities of erratic behaviour.

(3-pin - Order ref: CABL90, 5-pin - Order ref: CABL89)

Termination reduces signal transmission problems and interference. It is always advisable to connect a DMX terminal, (resistance 120 Ohm 1/4 W) between pin 2 (DMX-) and pin 3 (DMX+) of the last fixture.

5-pin XLR DMX connectors:

Some manufactures use 5-pin XLR connectors for data transmission in place of 3-pin. 5-pin XLR fixtures may be implemented in a 3-pin XLR DMX line. When inserting standard 5-pin XLR connectors in to a 3-pin line a cable adaptor must be used. The diagram below details the correct cable conversion.

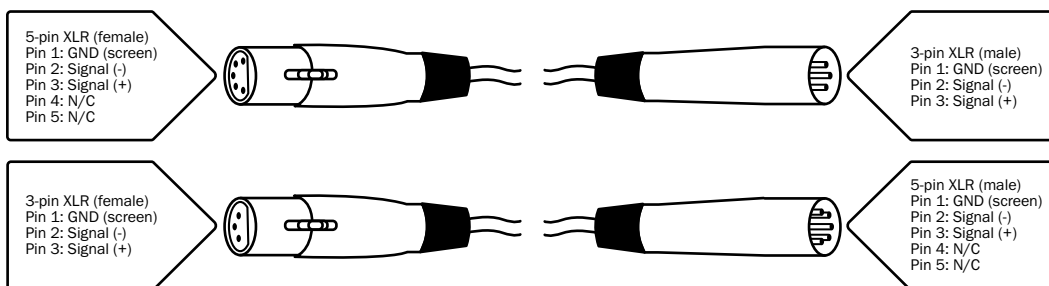



***Correct Disposal of this Product
(Waste Electrical & Electronic Equipment)***

**(Applicable in the European Union and other European countries
with separate collection systems)**

This marking shown on the product or its literature, indicates that it should not be disposed with other household wastes at the end of its working life. To prevent possible harm to the environment or human health from uncontrolled waste disposal, please separate this from other types of wastes and recycle it responsibly to promote the sustainable reuse of material resources.

Household users should contact either the retailer where they purchased this product, or their local government office, for details of where and how they can take this item for environmentally safe recycling.

Business users should contact their supplier and check the terms and conditions of the purchase contract. This product should not be mixed with other commercial wastes for disposal.



elumen8

