

EQUINOX

Swing Batten

User Manual



Order code: EQLED033

WARNING

FOR YOUR OWN SAFETY, PLEASE READ THIS USER MANUAL CAREFULLY BEFORE YOUR INITIAL START-UP!

- Before your initial start-up, please make sure that there is no damage caused during transportation.
- Should there be any damage, consult your dealer and do not use the equipment.
- To maintain the equipment in good working condition and to ensure safe operation, it is necessary for the user to follow the safety instructions and warning notes written in this manual.
- Please note that damages caused by user modifications to this equipment are not subject to warranty.



IMPORTANT:

The manufacturer will not accept liability for any resulting damages caused by the non-observance of this manual or any unauthorised modification to the equipment.

- Never let the power cable come into contact with other cables. Handle the power cable and all mains voltage connections with particular caution!
- Never remove warning or informative labels from the unit.
- Do not open the equipment and do not modify the unit.
- Do not connect this equipment to a dimmer pack.
- Do not switch the equipment on and off in short intervals, as this will reduce the system's life.
- Only use the equipment indoors.
- Do not expose to flammable sources, liquids or gases.
- Always disconnect the power from the mains when equipment is not in use or before cleaning! Only handle the power-cable by the plug. Never pull out the plug by pulling the power-cable.
- Make sure that the available mains supply voltage is between 100~240V AC, 50/60Hz.
- Make sure that the power cable is never crimped or damaged. Check the equipment and the power cable periodically.
- If the equipment is dropped or damaged, disconnect the mains power supply immediately and have a qualified engineer inspect the equipment before operating again.
- If the equipment has been exposed to drastic temperature fluctuation (e.g. after transportation), do not connect power or switch it on immediately. The arising condensation might damage the equipment. Leave the equipment switched off until it has reached room temperature.
- If your product fails to function correctly, stop use immediately. Pack the unit securely (preferably in the original packing material), and return it to your Pro Light dealer for service.
- Only use fuses of same type and rating.
- Repairs, servicing and power connection must only be carried out by a qualified technician. THIS UNIT CONTAINS NO USER SERVICEABLE PARTS.
- This lighting fixture is for professional use only - it is not designed for or suitable for household use. The product must be installed by a qualified technician in accordance with local territory regulations. The safety of the installation is the responsibility of the installer. The fixture presents risks of severe injury or death due to fire hazards, electric shock and falls.
- Warning! Risk Group 2 LED product according to EN 62471. Do not view the light output with optical instruments or any device that may concentrate the beam.
- WARRANTY: One year from date of purchase.

OPERATING DETERMINATIONS

If this equipment is operated in any other way, than those described in this manual, the product may suffer damage and the warranty becomes void. Incorrect operation may lead to danger e.g: short-circuit, burns and electric shocks etc.

Do not endanger your own safety and the safety of others!

Incorrect installation or use can cause serious damage to people and/or property.

Swing Batten

The Swing Batten is a dynamic multi-beam effect dispensing eight intense, long-throw beams generated by the 10W CREE quad-colour LEDs. The batten cuts through haze with ease producing stunning beam effects. The 4 button menu system allows control of master/slave functions, and the fixture can be also be operated in sound active and DMX modes.

- 8 x 10W CREE quad-colour LEDs (RGBW)
- Beam angle: 4°
- 16,100 Lux @ 2m (per LED, full on)
- Individually controllable LEDs
- Refresh rate: 400Hz
- DMX channels: 6/12 or 16 selectable
- Auto, sound active and master/slave modes
- Tilt: 220°
- 0-100% dimming and variable strobe
- Quick release omega clamps included
- 4 push button menu with LED display
- PowerCON input/output
- 3-Pin XLR input/output
- Convection cooled



Specifications	
Power consumption	100W
Power supply	100~240V, 50/60Hz
Fuse	F3A 250V
Dimensions	160 x 1065 x 80mm
Weight	7.5kg
Order code	EQLED033

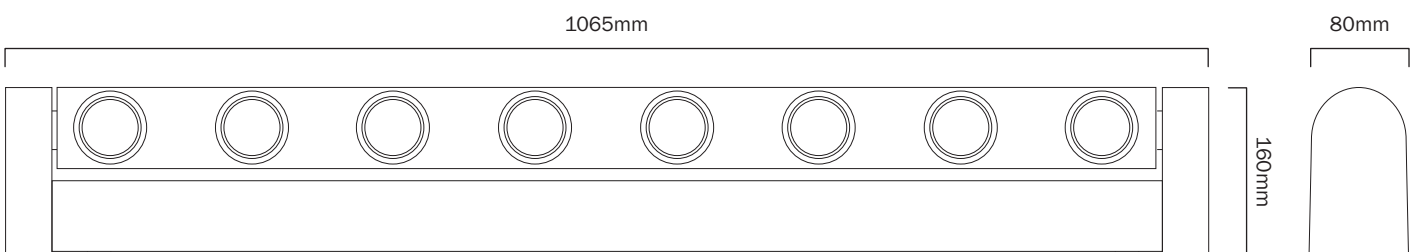

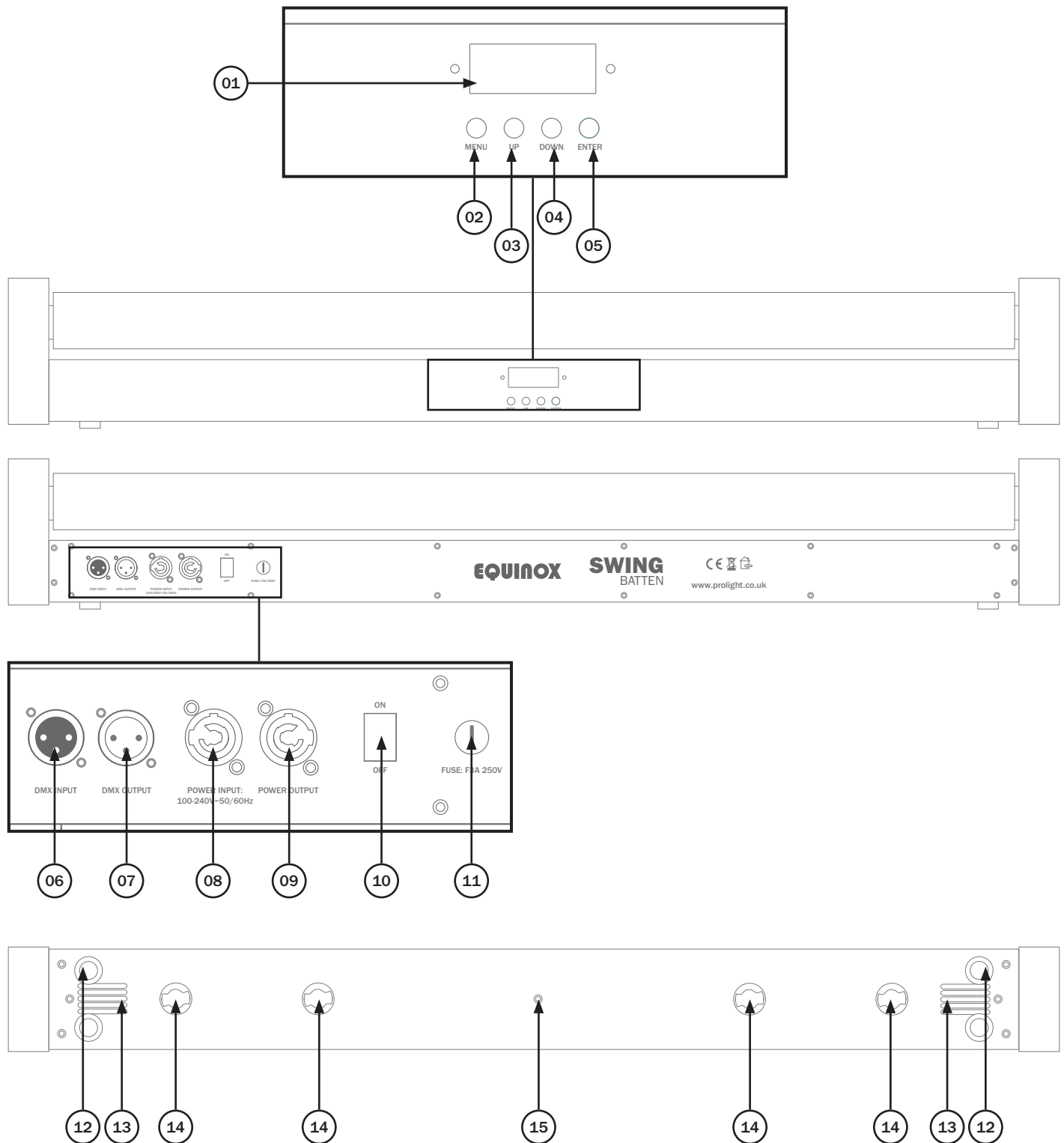

01 - LCD display
 02 - Menu button
 03 - Up button
 04 - Down button
 05 - Enter button

06 - 3-pin DMX input
 07 - 3-pin DMX output
 08 - PowerCON input
 09 - PowerCON input
 10 - On/off switch

11 - Fuse F3A 250V
 12 - Rubber feet
 13 - Vents
 14 - Omega clamp mounts
 15 - Safety bond point

In the box: **1 x fixture,**
1 x power cable,
1 x user manual &
2 x omega clamps

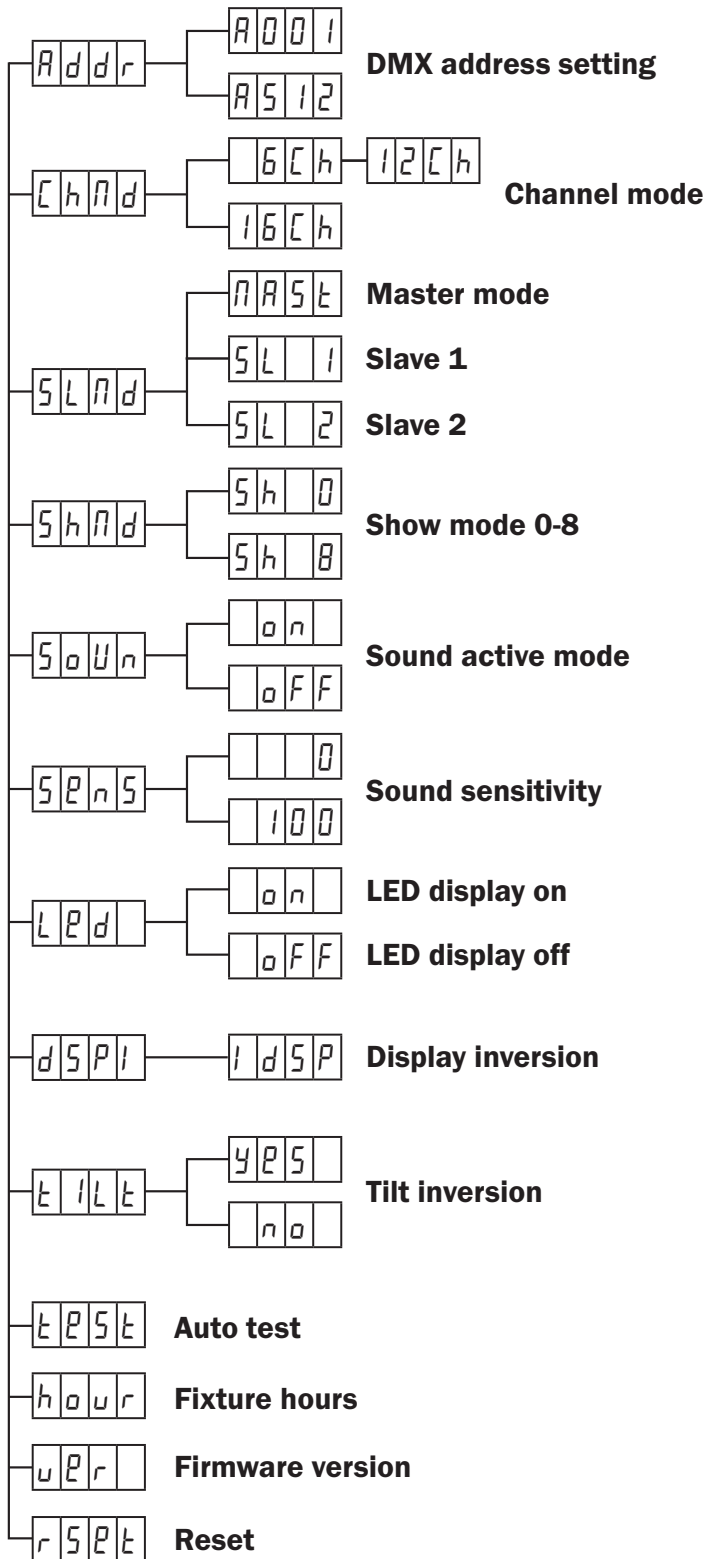

DMX mode:

Operating in a DMX control mode environment gives the user the greatest flexibility when it comes to customising or creating a show.

In this mode you will be able to control each individual trait of the fixture and each fixture independently.

To access the DMX address mode, press the “MENU” button on the front of the unit to show *Addr* on the LED display. Now press the “ENTER” button and use the “UP” and “DOWN” buttons to set the required DMX address. Press the “ENTER” button to confirm the setting.

To exit out of any of the above options, press the “MENU” button.

To access the DMX channel mode, press the “MENU” button on the front of the unit to show *Chnd* on the LED display. Now press the “ENTER” button and use the “UP” and “DOWN” buttons to choose one of the 6, 12 or 16 DMX channel modes. Press the “ENTER” button to confirm the setting.

To exit out of any of the above options, press the “MENU” button.

6 channel mode:

Channel	Value	Function
CH1	000-255	Master dimmer (0-100%)
CH2	000-007	No function
	008-255	Strobe (slow-fast)
CH3	000-007	No function
	008-049	Show 1
	050-091	Show 2
	092-133	Show 3
	134-175	Show 4
	176-217	Show 5
	218-247	Show 6
	248-255	Sound active
CH4	000-255	Show mode speed (slow-fast)
CH5	000-005	No function
	006-009	R
	010-013	G
	014-017	B
	018-021	W
	022-025	RG
	026-029	RB
	030-033	RW
	034-037	GB
	038-041	GW
	042-045	BW
	046-049	RGB
	050-053	RGW
	054-057	RBW
	058-061	GBW
	062-063	RGBW
	064-079	Colour chase 1
	080-095	Colour chase 2
	096-111	Colour chase 3
	112-127	Colour chase 4
	128-143	Colour chase 5
	144-159	Colour chase 6
	160-175	Colour chase 7
	176-191	Colour chase 8
192-207	Colour chase 9	
208-223	Colour chase 10	
224-239	Colour chase 11	
240-255	Colour chase 12	
CH6	000-255	Colour chase speed (slow-fast)

12 channel mode:

Channel	Value	Function
CH1	000-255	Tilt (0°-270°)
CH2	000-255	Tilt movement speed
CH3	000-255	Master dimmer (0-100%)
CH4	000-007	No function
	008-255	Strobe (slow-fast)
CH5	000-008	No function
	009-024	LED 1 - R
	025-041	LED 1 - G
	042-057	LED 1 - B
	058-074	LED 1 - W
	075-090	LED 1 - RG
	091-107	LED 1 - RB
	108-123	LED 1 - RW
	124-140	LED 1 - GB
	141-156	LED 1 - GW
	157-173	LED 1 - BW
	174-189	LED 1 - RGB
	190-206	LED 1 - RGW
	207-222	LED 1 - RBW
223-239	LED 1 - GBW	
240-255	LED 1 - RGBW	
CH6	-	LED 2 (use values from CH5)
CH7	-	LED 3 (use values from CH5)
CH8	-	LED 4 (use values from CH5)
CH9	-	LED 5 (use values from CH5)
CH10	-	LED 6 (use values from CH5)
CH11	-	LED 7 (use values from CH5)
CH12	-	LED 8 (use values from CH5)

16 channel mode:

Channel	Value	Function
CH1	000-255	Tilt (0°-270°)
CH2	000-255	Tilt movement speed
CH3	000-255	Master dimmer (0-100%)
CH4	000-007	No function
	008-255	Strobe (slow-fast)
CH5	000-008	No function
	009-024	LED 1 - R
	025-041	LED 1 - G
	042-057	LED 1 - B
	058-074	LED 1 - W
	075-090	LED 1 - RG
	091-107	LED 1 - RB
	108-123	LED 1 - RW
	124-140	LED 1 - GB
	141-156	LED 1 - GW
	157-173	LED 1 - BW
	174-189	LED 1 - RGB
	190-206	LED 1 - RGW
	207-222	LED 1 - RBW
	223-239	LED 1 - GBW
	240-255	LED 1 - RGBW
CH6	-	LED 2 (use values from CH5)
CH7	-	LED 3 (use values from CH5)
CH8	-	LED 4 (use values from CH5)
CH9	-	LED 5 (use values from CH5)
CH10	-	LED 6 (use values from CH5)
CH11	-	LED 7 (use values from CH5)
CH12	-	LED 8 (use values from CH5)
CH13	000-007	No function
	008-049	Show 1
	050-091	Show 2
	092-133	Show 3
	134-175	Show 4
	176-217	Show 5
	218-247	Show 6
	248-255	Sound active
CH14	000-255	Show mode speed (slow-fast)

CH15	000-005	No function
	006-009	R
	010-013	G
	014-017	B
	018-021	W
	022-025	RG
	026-029	RB
	030-033	RW
	034-037	GB
	038-041	GW
	042-045	BW
	046-049	RGB
	050-053	RGW
	054-057	RBW
	058-061	GBW
	062-063	RGBW
	064-079	Colour chase 1
	080-095	Colour chase 2
	096-111	Colour chase 3
	112-127	Colour chase 4
128-143	Colour chase 5	
144-159	Colour chase 6	
160-175	Colour chase 7	
176-191	Colour chase 8	
192-207	Colour chase 9	
208-223	Colour chase 10	
224-239	Colour chase 11	
240-255	Colour chase 12	
CH16	000-255	Colour chase speed (slow-fast)

Master/slave mode:

To set the master unit, press the “MENU” button on the front of the master unit to show *SLNd* on the LED display. Now press the “ENTER” button and use the “UP” and “DOWN” buttons to choose *MAST*. Press the “ENTER” button to confirm the setting. Then select your desired program (sound active, DMX or one of the built-in programs).

To set the other units in slave mode, press the “MENU” button on the front of the unit to show *SLNd* on the LED display. Now press the “ENTER” button and use the “UP” and “DOWN” buttons to choose either *SL 1* (Slave 1) or *SL 2* (Slave 2). Press the “ENTER” button to confirm the setting. The unit will now run in sequence with the master unit.

To exit out of any of the above options, press the “MENU” button.

Please ensure that all slave units are set to the same DMX channel mode as the master unit.

Show mode (built-in programs):

To access the show modes, press the “MENU” button on the front of the unit to show *ShNd* on the LED display. Now press the “ENTER” button and use the “UP” and “DOWN” buttons to choose the show you require from *Sh 0 ~ Sh 8*. Press the “ENTER” button to confirm the setting.

To exit out of any of the above options, press the “MENU” button.

Sound active mode:

To access the sound active mode, press the “MENU” button on the front of the unit to show *SoUn* on the LED display. Now press the “ENTER” button and use the “UP” and “DOWN” buttons to set the sound mode on or off. Press the “ENTER” button to confirm the setting.

To adjust the sound sensitivity, press the “MENU” button on the front of the unit to show *SEnS* on the LED display. Now press the “ENTER” button and use the “UP” and “DOWN” buttons to set the sound sensitivity *0 ~ 100*. Press the “ENTER” button to confirm the setting.

Value: 0 - 100 (0 = low sensitivity, 100 = high sensitivity)

To exit out of any of the above options, press the “MENU” button.

Setting the DMX address:

The DMX mode enables the use of a universal DMX controller. Each fixture requires a “start address” from 1- 512. A fixture requiring one or more channels for control begins to read the data on the channel indicated by the start address. For example, a fixture that occupies or uses 7 channels of DMX and was addressed to start on DMX channel 100, would read data from channels: 100,101,102,103,104,105 and 106. Choose a start address so that the channels used do not overlap. E.g. the next unit in the chain starts at 107.

DMX 512:

DMX (Digital Multiplex) is a universal protocol used as a form of communication between intelligent fixtures and controllers. A DMX controller sends DMX data instructions from the controller to the fixture. DMX data is sent as serial data that travels from fixture to fixture via the DATA “IN” and DATA “OUT” XLR terminals located on all DMX fixtures (most controllers only have a data “out” terminal).

DMX linking:

DMX is a language allowing all makes and models of different manufactures to be linked together and operate from a single controller, as long as all fixtures and the controller are DMX compliant. To ensure proper DMX data transmission, when using several DMX fixtures try to use the shortest cable path possible. The order in which fixtures are connected in a DMX line does not influence the DMX addressing. For example; a fixture assigned to a DMX address of 1 may be placed anywhere in a DMX line, at the beginning, at the end, or anywhere in the middle. When a fixture is assigned a DMX address of 1, the DMX controller knows to send DATA assigned to address 1 to that unit, no matter where it is located in the DMX chain.

DATA cable (DMX cable) requirements (for DMX operation):

This fixture can be controlled via DMX-512 protocol. The DMX address is set on the back of the unit. Your unit and your DMX controller require a standard 3-pin XLR connector for data input/output, see image below.



Further DMX cables can be purchased from all good sound and lighting suppliers or Pro Light Concepts dealers.

Please quote:

CABL10 – 2m

CABL11 – 5m

CABL12 – 10m

Also remember that DMX cable must be daisy chained and cannot be split.

Notice:

Be sure to follow the diagrams below when making your own cables. Do not connect the cables shield conductor to the ground lug or allow the shield conductor to come in contact with the XLRs outer casing. Grounding the shield could cause a short circuit and erratic behaviour.

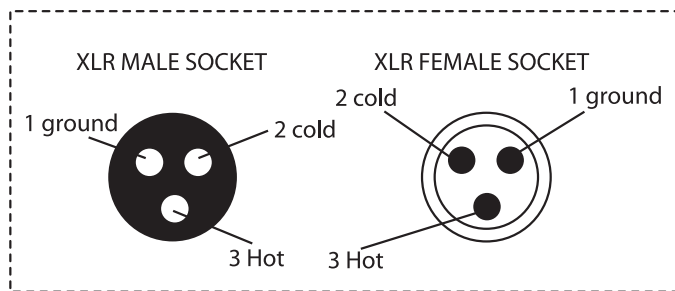
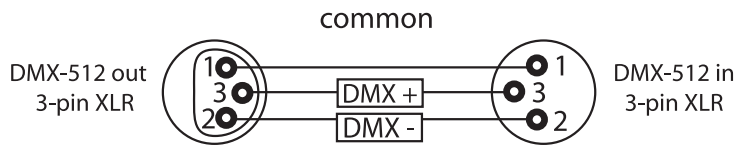

XLR Pin Configuration
Pin 1 = Ground
Pin 2 = Negative
Pin 3 = Postive

Special note:

Line termination:

When longer runs of cable are used, you may need to use a terminator on the last unit to avoid erratic behaviour.

Using a cable terminator will decrease the possibilities of erratic behaviour.

(3-pin - Order ref: CABL90, 5-pin - Order ref: CABL89)

Termination reduces signal transmission problems and interference. it is always advisable to connect a DMX terminal, (resistance 120 Ohm 1/4 W) between pin 2 (DMX-) and pin 3 (DMX+) of the last fixture.

5-pin XLR DMX connectors:

Some manufactures use 5-pin XLR connectors for data transmission in place of 3-pin. 5-pin XLR fixtures may be implemented in a 3-pin XLR DMX line. When inserting standard 5-pin XLR connectors in to a 3-pin line a cable adaptor must be used. The diagram below details the correct cable conversion.

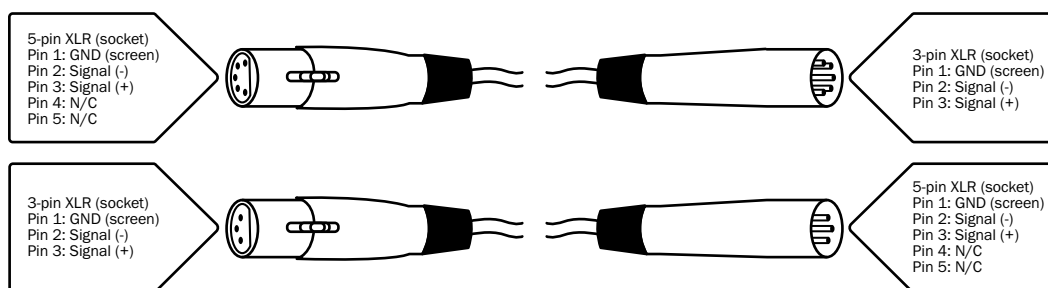



Correct Disposal of this Product (Waste Electrical & Electronic Equipment)

**(Applicable in the European Union and other European countries
with separate collection systems)**

This marking shown on the product or its literature, indicates that it should not be disposed of with other household wastes at the end of its working life. To prevent possible harm to the environment or human health from uncontrolled waste disposal, please separate this from other types of wastes and recycle it responsibly to promote the sustainable reuse of material resources.

Household users should contact either the retailer where they purchased this product, or their local government office, for details of where and how they can take this item for environmentally safe recycling.

Business users should contact their supplier and check the terms and conditions of the purchase contract. This product should not be mixed with other commercial wastes for disposal.



EQUINOX