

# USER MANUAL

RevA 06-2017

# RPS-1620

## STEREO RACK MIXER

## Welcome

Thank you for choosing Hill Audio for your sound system. To make sure that this product meets your expectations and provides long-term, reliable performance, please read and follow this instruction manual carefully.

## Manual Language

UK	This user manual is written in English. For other languages, visit	<a href="http://www.hill-audio.com">www.hill-audio.com</a>
FR	Ce guide est écrit en anglais. Pour les autres langues, visitez:	<a href="http://www.hill-audio.com">www.hill-audio.com</a>
DE	Diese Anleitung ist in Englisch verfasst. Für andere Sprachen:	<a href="http://www.hill-audio.com">www.hill-audio.com</a>
ES	Este manual está escrito en Inglés. Para otros idiomas, visite:	<a href="http://www.hill-audio.com">www.hill-audio.com</a>
PT	Este manual está escrito em Inglês. Para outros idiomas, visite:	<a href="http://www.hill-audio.com">www.hill-audio.com</a>
IT	Questo manuale è scritto in inglese. Per altre lingue, visitare:	<a href="http://www.hill-audio.com">www.hill-audio.com</a>

## Important safety instructions

- Read these instructions and all markings on the product. Keep these instructions.
- Heed all warnings and instructions, both in this manual and on the product.
- Clean only with a dry cloth. Unplug from AC supply before cleaning.
- Do not use this product near water and avoid any exposure to water.
- Before connecting this product to any AC supply, make sure to check whether the AC mains voltage and frequency match the indication on the product and its packaging.
- Only connect this product to an AC supply with sufficient power handling, protective earth connection, ground-fault (earth-fault) protection and overload protection.
- Disconnect the product from the AC supply during thunderstorms or longer periods of being unused.
- Make sure any heat sink or other cooling surface, or any air convection slot, is exposed sufficiently to free air circulation and is not blocked.
- Do not operate this product in environmental temperatures exceeding 35 degrees Celsius and/or 85% relative humidity.
- Position the product in a safe and stable place for operation, out of reach of unauthorized persons.
- Make sure any cable connections to and from the product are neither subject to potentially destructive mechanical impact nor present any risk of stumbling or other accident risk to people.
- Audio equipment may generate sound pressure levels sufficient to cause permanent hearing damage to persons. Always start up at low volume settings and avoid prolonged exposure to sound pressure levels exceeding 90 dB.
- Do not open this product for service purposes. There are no user-serviceable parts inside. Warranty will be void in any case of unauthorized service by the user or other not authorized persons.
- Take any precaution required by local law, applicable regulations or good business practice to avoid injury of people or material damage by use of this product.

Explanation of symbols used in this manual and on the product:



**ATTENTION!**  
Read manual before installation and operation.



**DANGER!**  
Safety hazard.  
Risk of injury or death.



**WARNING!**  
Hazardous voltage.  
Risk of severe or fatal electric shock.



**WARNING!**  
Fire hazard.

## Description

The RPS-1620 is an 8-input stereo rack mixer in a compact 19"/1U case. With each input sporting controls for level, balance and an AUX bus, it is the perfect submixer for both distributed sources in larger installed sound systems as well as a multitude of local sources like with keyboard players or electronic drum players.

## Health advice

This unit produces and absorbs electromagnetic radiation. The strength of radiation and the sensitivity for disturbing interference matches the CE and FCC requirements. A corresponding sign is printed on the backside of the unit. Any change or modification may affect the behavior of the unit concerning electromagnetic radiation, with the CE requirements eventually not to be met any more. The manufacturer takes no responsibility in this case.

## Functional advice

This unit is immune to the presence of electromagnetic disturbances – both conducted and radiated - up to a certain level. Under peak conditions, the unit is classified to show a “class C” performance criteria and may encounter temporary degradation or loss of function which may need manual help to recover. In such case, disconnect the AC power from the unit and reconnect it again to recover.

## Environmental advice

This unit is built to conform to the ROHS standards and the WEEE directive 2002/96/EC of the European Parliament and of the Council of the European Union. Under these regulations, the product shall not be discarded into regular garbage at the end of its life, but shall be returned to authorized recycling stations.

## Unpacking

Please check that the box contains the following items:

Main parts:    1 pc. RPS-1620 main unit  
                   1 pc. Mains cable  
                   1 pc. Operation manual

If any part is missing, please contact your dealer immediately for replacement.

## Warning



After unpacking, and before plugging the AC cord in the wall outlet, check whether the AC mains voltage and frequency is the same as this product is specified for (see rear panel of product). Whenever the specified voltage or your AC plug should not match the local conditions, do NOT plug the AC cord into the wall outlet and contact your dealer immediately.

## AC mains voltage setting

If the AC mains voltage of your power outlet and the setting of the AC supply voltage on your unit do not match, contact your dealer, contractor or a qualified service workshop to change the setting of the AC voltage selector. The AC voltage selector switch is located on the side panel of the unit, close to the AC inlet.

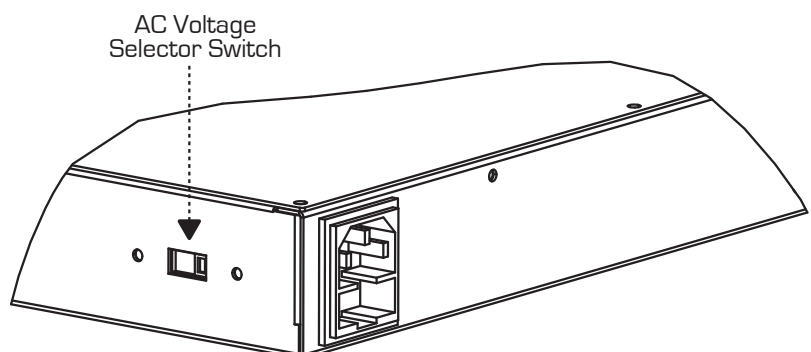

## Controls and Connections

### Connections - Rear

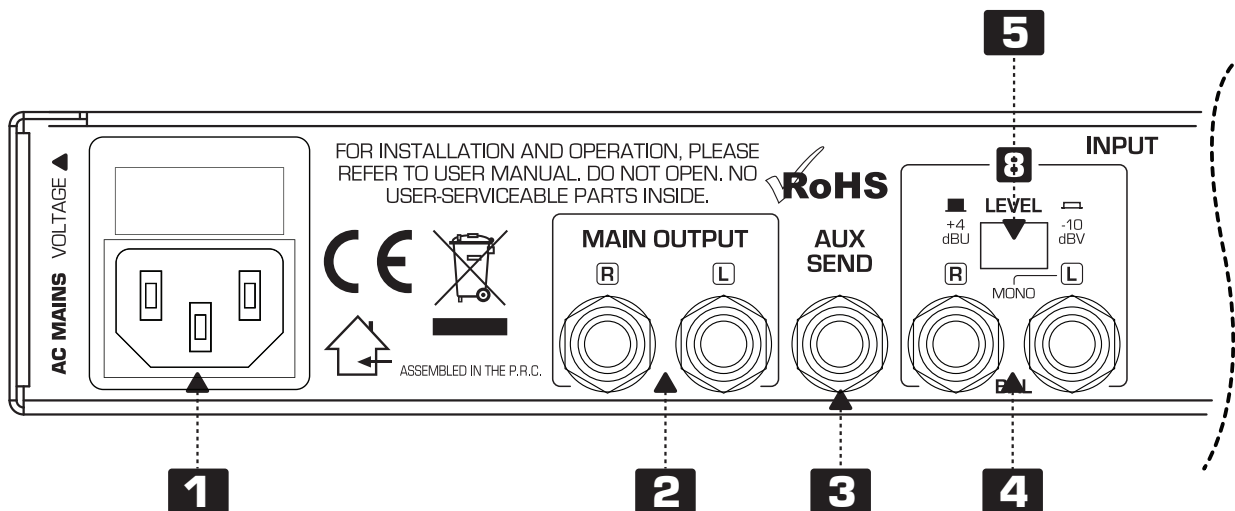

### Controls - Front

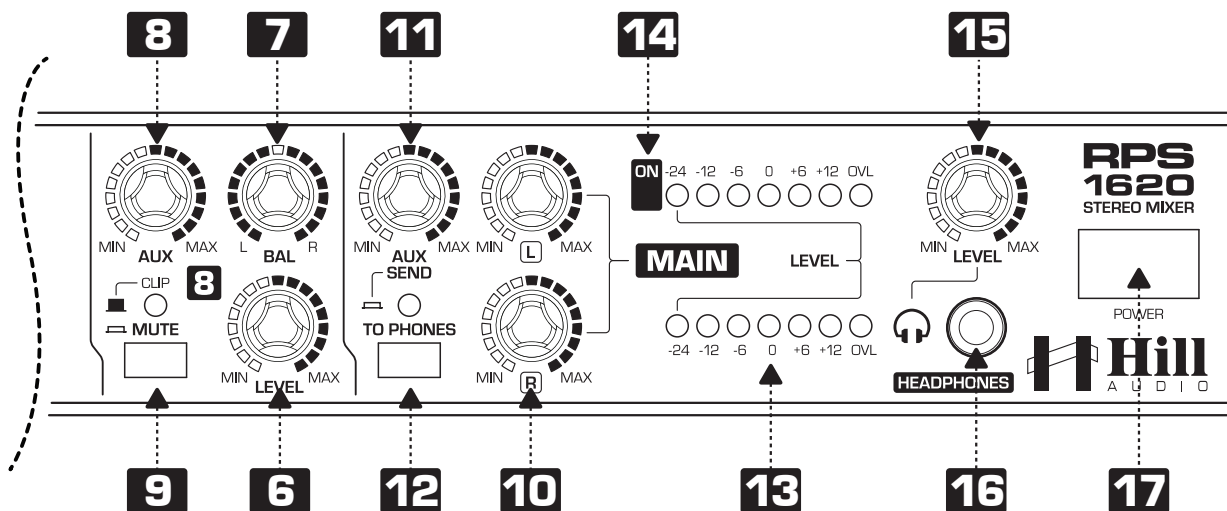

## Functional Description

The RPS-1620 is an 8-input stereo line mixer with controls for level, balance and one AUX bus per input channel. A master section with LED meter, AUX send and pre-listening section completes this unit which serves all sub-mixing tasks in installations and music production.

- 1** AC inlet and fuse holder. Use the supplied AC cord to connect the unit to AC mains. Make sure voltage and frequency stated and set on the unit comply with your local AC supply. The fuse can be accessed by the small drawer at the AC inlet. To change the fuse, unplug the AC cord first, pull out the fuse drawer and replace the fuse **ONLY** with a fuse of **SAME** voltage and rating. If the fuse blows again after replacement, hand over the unit to qualified service personnel.
- 2** OUTPUT connectors (left and right channel). These are both balanced TRS connectors. Connect following devices of your sound system (main mixer, amplifiers, etc) here.
- 3** AUX SEND connector. This is a balanced mono output of the AUX bus and will carry the respective signals mixed from the setting of the AUX controls in the input channels (8) and the AUX send volume control (11).
- 4** INPUT connectors (channels 1...8). These are two balanced TRS connectors for the left and right channel of each input signal respectively. Connect your line level audio sources here. If the incoming signal is only mono, connect this to the input indicated as LEFT.
- 5** LEVEL switch. Switches the input sensitivity from +4dBu to -10 dBV, making the inputs (4) more sensitive.
- 6** LEVEL controls (channels 1...8) . Turning these controls counterclockwise reduces the level down to  $-\infty$ , turning them clockwise increases the level to up to +15 dB.
- 7** BALANCE control (channel 1...8). For mono input signals, this control sets the position of the signal in the stereo image, and for stereo input signals, it regulates the ratio of left/right channel signals.
- 8** AUX volume control (channel 1...8). This sets the signal level of the respective channel for monitoring or effects purposes, by mixing every channel to the internal AUX bus. The total volume of the AUX bus can then be set by the control (11) and the signal can be picked up at the AUX Send (3) for further processing. Note that these controls are pre-LEVEL control (6), so even if the LEVEL control (6) is turned down, the signal will still be present at the AUX bus.
- 9** MUTE switch. This switch mutes the respective channel upon pressing. Once pressed, the attached control LED will light up constantly to indicate the muted status. If the switch is not pressed, the LED functions as a CLIP indicator, indicating the input signal exceeding +17 dBu.
- 10** MAIN volume control. Allows to set the total output volume of the mix present at the main output (2) separately for the left and right channel.
- 11** AUX SEND volume control. Sets the total level of the AUX bus mix signal created by the channel AUX volume controls (8) and present at the mono AUX SEND output (3).
- 12** TO PHONES switch. Switches the headphones' source from the main output signal (not pressed) to the AUX bus signal (pressed). A LED indicates the status.
- 13** LEVEL meter. Displays the output level at the main output connectors (2).
- 14** POWER indicator. Lights up when the unit is switched on.

- 15** HEADPHONES volume control. Sets the output volume for the headphones output (16)
- 16** HEADPHONES output. This is a 3.5mm mini TRS jack for the connection of standard headphones with impedances no lower than 32 Ohms. The volume is controlled by (15).
- 17** POWER switch. Switches the unit on and off. Make sure the unit is always switched off when not being in use. The status is indicated by the POWER LED (14).

### Connections

The RPS-1620 uses the below connector types, for which the pin assignment must comply with the following specification. Always make sure to use good connectors and cables to ensure proper operation. Balanced connections are to be preferred over unbalanced connections where applicable and feasible. Avoid unbalanced connections exceeding 2m of cable length.

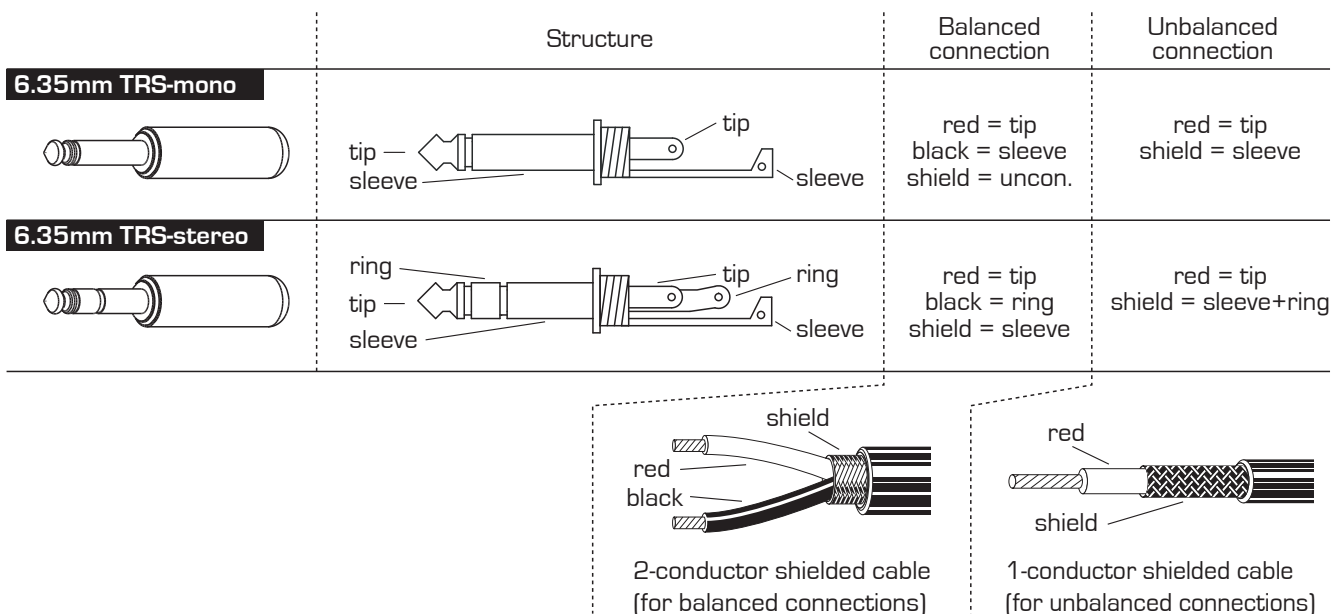

### Technical Specifications

Signal/Noise.....>95dB (unwgted 22Hz-22KHz)  
 Crosstalk Damping.....>70dB  
 THD.....<0.01% (Line)  
 Frequency response.....20Hz – 20 kHz  
 AC IN.....AC115V/230V~ 50/60Hz

Power consumption.....max. 15W  
 Dimensions.....W483(427)xH44.5xD162.0mm  
 (parentheses = without rack ears)  
 Weight.....2.46kg

### Maintenance and warranty

While we have chosen the best components to make this product as rugged and reliable as possible, some parts in audio products (potentiometers, faders, switches) are subject to wear which is a matter of operation cycles, and not of time. While providing a full time-based warranty according to the country's of purchase requirements on the function of the electronic circuitry, we hence have to limit the warranty on such electro-mechanical parts to 90 days from the date of purchase.

In many cases, malfunction of electro-mechanical parts occurs due to dust contamination, which may require cleaning of such parts. As the inside of such parts is not accessible, a common practice is to use cleaning fluids in the shape of sprays. Please be reminded that many of such fluids contain chemicals which may wash away the dust but at the same time corrode or damage contact surface and may cause cosmetic damage to other parts. We hence explicitly exclude any claims for exchange of damaged part due to mechanical or chemical impact.

## Operation

### A. Connections

For connecting this unit to AC mains, please note:

- Check whether the AC mains voltage and frequency is the same as this product is specified for (see rear panel of product). Whenever the specified voltage or your AC plug should not match the local conditions, do NOT plug the AC cord into the wall outlet and contact your dealer immediately.
- Do not operate this unit without the line cord earth ground connected. To do so may increase the risk of electric shock and increase line cord conducted emissions.

For making audio signal connections, always remember that good and reliable connections are a basic requirement for good sound and reliable operation. Bad soldering of cables can result in intermittent audio signals or temporarily lost ground connections, hence always use good cables. In case of doubt about making proper connections, please see check the standard pin assignments required for proper operation in the following section of this manual.

### B. Powering up

Following a proper power-up sequence protects your equipment – specifically speakers – and your ears. Follow the below procedure:

- Turn down all output volume controls of any equipment in your audio system.
- Switch on your audio sources first (Tuners, CD Players, PC's with soundcards, Tapedecks, etc.)
- Switch on the audio mixer
- Switch on any audio processor between the mixer and the amplifier(s) [if any].
- Switch on the amplifier(s).
- Turn up the audio level on your sources if such controls are provided.
- Set the audio output of your mixer to a low level.
- Set the audio output of any audio processor between the mixer and the amplifier(s) to a medium level [if any such processors].
- Turn up the volume controls of your amplifier(s) slowly.
- Make adjustments to all volume settings as needed.

For switching off, follow the inverse sequence – always switch off your amplifier(s) first, then any processors between mixer and amplifier(s), then the mixer, then the sources.

### C. Use

Apart from using good equipment, good sound comes from using it correctly. Level setting mistakes are one of the common reasons why even good equipment may not perform as desired. For setting levels, please be reminded that two guidelines need to be followed:

- Avoid distortion by leaving some headroom. Never overrun any audio-equipment's inputs. Level meters and displays allow you to make sure that signals do not enter critical levels.
- Avoid unnecessary amplification by using as little attenuation as possible. For example, if you turn down the input gain of a mixer to minimum, and then increase the main output of the mixer to maximum to drive your amplifier properly, you will create unnecessary noise, as you first dispose of some already existing signal level, and then later apply amplification (tainted with noise) to make it up.

Obviously, these two requirements are marking a levelling window that the operator must match to achieve a good sound with as little distortion and noise as possible.



#### **WARNING - HEALTH RISK**

Excessive volume levels on headphones or other sound systems may cause hearing damage. Always turn the volume control to minimum when you switch the unit on, and avoid prolonged exposure to sound pressure levels exceeding 90dB.

# EC Declaration of Conformity

Manufacturer: Adelto Technologies Limited  
Address: Unit 2A Springfield Road, Springfield Industrial Estate  
Burnham-on-Crouch, Essex CM08UA, England

We declare on our own responsibility, that the equipment

## Hill Audio RPS-1620

is in conformity with the following directives and standards or regulations:

**EMC Directive 2014/30/EU**  
EN55032:2012 (Emissions)  
EN55103-2:2009 (Immunity)  
EN61000-3-2:2014  
EN61000-3-3:2013

**LVD Directive 2014/35/EU**  
EN60065:2014

**ROHS2 Directive 2011/65/EU**

and is marked as follows:



Burnham-on-Crouch, 30.06.2017  
Place and date of issuing

  
Authorized Signature

[www.hill-audio.com](http://www.hill-audio.com)



Hill Audio products are developed, manufactured and distributed by  
**Adelto Technologies**

Unit 2A Springfield Road, Springfield Industrial Estate, Burnham-on-Crouch, Essex CM08UA, England  
[www.adelto.com](http://www.adelto.com) | [sales@adelto.com](mailto:sales@adelto.com)