

■ **Technical data MULTIWALL-GII-HS3049**

Panels/Output.....1 panel, 2300 lm
 LEDs per panel:49x1W 1-chip
 Arrangement..... 16x1W red 21x1W green 12x1W blue
 Optics.....Secondary, 25x75 degrees elliptical
 Power consumption.....60W

■ **Technical data MULTIWALL-GII-HT3024**

Panels/Output.....1 panel, 2840 lm
 LEDs per panel:24x3W RGB 3-in-1
 Arrangement..... 24x1W red 24x1W green 24x1W blue chip
 Optics.....Secondary, 25 degrees
 Power consumption.....85W

■ **Common technical data**

DMX Control.....3-5 Channels
 IP Rating.....20 (indoor)/65 (outdoor)
 Mains Input.....AC100-250V~ 50/60Hz
 Power supply type.....switch mode
 Fuse.....internal (see service manual)
 DMX connections.....3 pin XLR (Male / Female)
 Modulation Type.....Pulse Density Modulation (PDM)
 Control protocol.....DMX 512 (1990)
 Dimensions LxWxH..... 1011.0 x 75.5 x101.5mm
 Weight.....7.1kg

■ **Standards**

This product complies with the following standards:

EU electrical safety.....EN60598-1:2008, EN60598-2-1:1989
 EU general safety..... EN60598-2-17
 EU photobiological safety.....EN 62471:2008
 EU EMC.....EN55015: 2006 + A1:2007, EN61547:1995 + A1:2000
 EU HarmonicsEN61000-3-2:2006
 EU FlickerEN61000-3-3:2008
 US safetyUL60065
 US EMC.....FCC Part 15

This product meets both the EMC Directive 2004/108/EC and the Low Voltage Directive 2006/95/EC.

Ask your dealer or visit www.multiform-lighting.com for more information.

USER MANUAL

MULTIWALL G-II-HS3049 / HT3024

High-Power DMX-Controlled linear light source

For firmware 50-010-0088-00113-1-04 Firmware GII RevN

ENGLISH Page 2-20



Updated versions of this document may be available at
WWW.MULTIFORM-LIGHTING.COM

RevA 05/2012 Order code: 12-010-0113-80301-1-01

■ Introduction

Dear customer,

congratulations on the purchase of a Multiform-branded item and the trust having been put in us with this decision. Multiform is one of the leading global manufacturers of professional lighting equipment and has decades of experience in design, production and quality assurance.

To meet your requirements, this unit has been designed and built to the highest standards, so that we can assure you that you have made a good and satisfying investment. To take full advantage of all possibilities and for your own safety and the safety of your environment, please read these operating instructions carefully before you start using the unit.

■ Description

The MultiWall GII is a high-power DMX-controlled LED light source for both indoor and outdoor applications, which range from architectural illumination to stage lighting. This fixture has been designed for flexibility and reliability, which includes various connection options and an advanced cooling system allowing for longer LED lifetime.

SAFETY INFORMATION



Read the safety precautions in this chapter before installing, powering up, operating or servicing this device. Failure to do so may void the product warranty, and releases the manufacturer from all product liability.

■ Symbols used in this manual

The following symbols are used to identify important safety information on the product and in this manual:



WARNING! Read manual before installation, operation or servicing.



WARNING! Safety hazard. Risk of injury or death.



WARNING! Hazardous voltage. Risk of severe or fatal electric shock.

Reset. Use the left/right arrows until the display shows "RSET". Press the + or the - button to enter the RESET MODE and the display will show 'YES+' Press the + button to activate a reset to the factory default settings and calibration (the - button is disabled in this menu). For confirmation, the LED panel flashes once. The reset excludes the operation hours.

Operation Hours. Use the left/right arrows until the display shows HOUR. Press the - button and the display will show the operating hours up to 9999 hours. Operating hours exceeding the first 9999 hours can be extracted from the unit via RDM by a qualified service technician.

FW Version. Use the left/right arrows until the display shows VERS. Press either of the -/+ buttons to have the display showing the firmware version.

■ Maintenance

This device does not need regular maintenance. It is protected by an internal fuse located on the power supply PCB. If this fuse fails, this usually indicates an internal fault requiring servicing by a qualified engineer. The fuse shall only be replaced by a fuse of same specification, and the replacement has to be made by qualified personnel obeying applicable safety rules.

DO NOT try to leave the control mode/channel scheme choice by pressing the left/right arrow buttons; this would change the control mode/channel scheme to the next subsequent choice. Always leave this mode by either pressing the MODE button or by simply waiting until the display returns to show "GDMX".

■ **COLOR BALANCE**

In this Mode you can define your individual fixture's Color Balance by setting a maximum brightness for each LED colour giving you the individual color balance you desire. Press the MODE button until the display shows "CBAL". Use the left/right arrow buttons to select any of the following options: „Rxxx“, „Gxxx“ and „Bxxx“ with „xxx“ being values between 200 and 255. Value settings below 200 are disabled to avoid unwanted output reduction of the fixture. If you want to change the maximum output of the colour being displayed use the +/- buttons to do so. For control purposes all LED's are lit with their chosen maximum value. All changes made become effective immediately. If pressing the MODE button during editing a color level, the display returns to 'CBAL'.

Note: Any settings made in this mode will influence the overall color balance of the fixture (in all available operation modes – also DMX). To make sure that several fixtures used together to do not exhibit different color behaviour, please make sure that all fixtures used together are calibrated to the same color behaviour.

■ **EDIT**

Automatic DMX addressing. Use the left/right arrows until the display shows "ADMX". Use the + button to start the auto addressing process. This process assumes that it is executed from the first device in a chain. It will set all COLORMIX systems in the following devices to the same as the first device (master) and assign DMX channels consecutively.

Auto Lock. Use the left/right arrows until the display shows ALOK. Press any of the +/- button to alternate between "on" or "off". When on, the unit will lock itself after more than 1 minute of no use of the UI. When off, the UI will remain unlocked. To unlock a locked unit, press the left and the right arrow buttons simultaneously.

Auto Display off. Use the left/right arrows until the display shows ADIS. Press any of the +/- button to alternate between "on" or "off". When on, the unit will disable the LCD backlight after more than 1 minute of no use of the UI. When off, the display backlight will remain enabled. Note: The display elements themselves remain active.

Temperature Display. Use the left/right arrows until the display shows "TEMP". Press any of the +/- button to alternate between "on" or "off". When on, the unit will display the temperature in °C after more than 1 minute of no use of the UI.



WARNING! Shock hazard. Equipment must be properly grounded.



WARNING! Hot surface. Risk of skin burn or skin irritation.



WARNING! Fire hazard.



WARNING! Laser radiation. Risk of surface damage.



WARNING! LED light emission. Risk of eye injury.

■ **Security advice before use**



General advice:

1. Read this manual completely before using the product.
2. Keep this manual in your records for future reference.
3. Follow all instruction printed in this manual.
4. Follow all printed security advice on the product itself.
5. Take care of enough distance between this product and sources of hum and noise like electric motors and transformers.
6. Carry this product with greatest care. Punches, big forces and heavy vibration may damage this product mechanically.



Protection from eye injury

1. Warning: Depending on the configuration of the device, this device may reach or exceed the limits of EN62471, risk group 2, and may hence reach to risk group 3.
2. To avoid eye injury, do not look into the beam from a distance of less than 8.5 m (27 ft. 11 ins) from the front surface of the fixture without protective eyewear such as shade-5 welding goggles. At larger distances, light output is harmless to the naked eye provided that the eye's natural aversion response is not affected.
3. Do not view the beam directly with optical instruments such as magnifiers, telescopes, binoculars or similar optical instruments that may concentrate the light output.
4. Ensure that during setup and DMX programming, no persons are inside a 8.50m (27 ft. 11 ins) vicinity of the device's front surface, to avoid that they may accidentally be exposed to the light beam.

**Protection from electric shock:**

1. Only connect this unit to a mains socket outlet with protective earth connection, ground-fault (earth-fault) and overload protection.
2. Where the mains plug or an appliance coupler is used as a disconnect device, such device shall remain readily operable.
3. To pull the AC Cord out of the wall outlet or the unit's AC socket, never pull the cable itself, but only the AC plug.
4. Disconnect the unit from AC supply before any kind of cleaning on the product. Use smooth and dry cloth only for cleaning.
5. Do not expose this unit to any dripping or splashing liquids, and do not place objects filled with liquids, such as vases, on the unit.
6. Do not operate this unit near to open water or in high humidity.
7. Choose the position of the AC cord according to the lowest risk of damage by foot steps or by squeezing it.
8. Do not open the unit for service, there are no user-serviceable parts inside. Warranty will be void in any case of unauthorized service by the user or other not authorized persons.

**Protection from fire:**

1. Take care of not placing the unit near sources of heat (e.g. powerful amplifiers, fog machines).
2. Allow at least about 0.15m (6 ins.) between this unit and other devices or a wall to allow for proper cooling.
3. Take always care of sufficient air convection in the unit's environment to avoid overheating. Make sure air convection slots are not blocked. Do not operate this unit in environmental temperatures exceeding 40 degrees Celsius.
4. Be sure this fixture is kept at least 0.75m (30ins.) away from any flammable materials (decoration etc.).
5. Do not stick filters, masks or other materials directly on the LEDs or the LED cover screen.
6. Check the total maximum power of your AC wall outlet if you connect several units to one wall outlet and avoid any overloading.
7. If the device itself has an AC outlet for providing power to other units, make sure to not exceed the specified maximum load.

**Protection from injury and damage:**

1. Never use any accessories or modifications not authorized by the manufacturer of this unit.
2. Choose a location for operation where the unit is protected from vibration and where a fixed mounting position is provided. In case of overhead-mounting, follow applicable rigging requirements.
3. Before plugging the AC cord in the wall outlet, check whether the AC plug, the mains voltage and frequency are the same as this product is specified for. If not, contact you dealer immediately.

the left/right arrows, in this case the speed setting mode is left immediately and the speed will remain as last set.

■ DMX SLAVE MODE

Press the MODE button until the display shows "SLAx" whereas x stands for the numbers 1 to 4. The Slave mode offers 4 independent groups of slaves. Set the required slave group by using the +/- buttons, the display shows "SLA1" ... "SLA4". If no change is made for 0,5 sec. or longer, or the Menu is changed by using the MODE button, the relative setting is becoming active.

NOTE: Whenever a DMX signal is received, the "D" tab in the display is lit – this is valid for all DMX-related modes.

■ DMX GENERAL MODE / ADDRESS SETTING

Press the MODE button until the display shows "GDMX". By the first touch of the left or right arrow button the present DMX Mode will be displayed. Use these left/right arrow buttons to choose between any of the following color control modes/channel schemes:

- 3RAW = 3 colors RGB (3 channels)
- 3CCC = 3 colors RGB + combined master/strobe (4 channels, as old Multispot)
- 3CMS = 3 colors RGB + master + strobe (5 channels)
- HSLS = Hue Saturation Lightness + strobe (4 channels)
- PRES = Presets (allows to recall the preset colours and programmes of the unit)

Once having chosen the required control mode/channel scheme, please use the + or – buttons to set the required DMX address. Pressing the + or – button for the first time will show the present DMX address, which then can be altered by repeatedly using the +/- buttons in a range from 001 to 512. The display will show "1" ... "512" accordingly. Pressing the +/- buttons for longer than 1 second accelerates the change rate of the displayed value to 3 times.

If no change is made for 0,5 sec. or longer or the MODE button is pressed the relative settings become active. The display will only show the values presently being viewed or changed. After 30 sec. of no alterations or if the MODE button is pressed the display returns to show "GDMX".

NOTE: Whenever a DMX signal is received, the "D" tab in the display is lit – this is valid for all DMX-related modes.

The DMX channel setting is global – if you change the control mode/channel scheme later, the DMX start address will remain valid, but the number of consumed channels may change.

SL1..SL25	Strobe speed 1 Hz...18Hz
-----------	--------------------------

Choosing "S2L" activates the "Sound-to-Light" function shown by illuminating the "S" symbol in the display and displaying "S2L". The speed is now being driven by the beat of the music taken up by the built-in microphone.

Once the speed level is set or the S2L-function chosen and no changes done the display will return to show "SP0"... "SP12" after 5 seconds. The same happens if the pattern preset is changed by the left/right arrows, in this case the speed setting mode is left immediately and the speed will remain as last set.

■ FADE PATTERNS

In this mode you will only find soft fade patterns. Press the MODE button until the display shows "FPxx" whereas xx stands for numbers 00 until 07. The available patterns are defined as follow:

Pattern	Steps	Pattern	Steps
FP0	red-green	FP4	candy-lime
FP1	blue-green	FP5	candy-blue
FP2	blue-pink-red	FP6	candy-aqua-turquoise
FP3	yellow-lime-red	FP7	red-yellow-green-turquoise-blue-candy

Use the left/right arrows to change the pattern between any of the 8 presets, the display shows "FP0"... "FP07" accordingly and will remain to show unless the speed function is used. Use the +/- button to change the speed level. The first touch of the + or - button changes the display, now showing the speed level "SL00"... "SL25" representing the following speed levels:

Setting	Speed	Setting	Speed
SL0	1 loop per 960 seconds	SL13	1 loop per 3 seconds
SL1	1 loop per 480 seconds	SL14	1 loop per 2 seconds
SL2	1 loop per 360 seconds	SL15	1 loop per 1,5 seconds
SL3	1 loop per 240 seconds	SL16	1 loop per 1,25 seconds
SL4	1 loop per 120 seconds	SL17	1 loop per 1 second
SL5	1 loop per 80 seconds	SL18	1,2 loops per second
SL6	1 loop per 40 seconds	SL19	1,4 loops per second
SL7	1 loop per 20 seconds	SL20	1,6 loops per second
SL8	1 loop per 12 seconds	SL21	1,9 loops per second
SL9	1 loop per 10 seconds	SL22	2,2 loops per second
SL10	1 loop per 8 seconds	SL23	2,5 loops per second
SL11	1 loop per 6 seconds	SL24	2,8 loops per second
SL12	1 loop per 4 seconds	SL25	3,2 loops per second

Once the speed level is set and no changes done the display will return to show "FP0"... "FP7" after 5 seconds. The same happens if the pattern preset is changed by

- The surface of the device may get hot during operation, and heat sink areas may reach to or exceed the limits of EN60950. Do not touch heat sink areas of the device during operation, and allow 20 minutes of cool-down time after powering off before touching.
- If fluids have spilled into the unit or small parts have intruded the unit, immediately switch off the unit and hand it over to the authorized service for a security check.
- Disconnect the unit from AC supply by pulling the AC plug out of the wall outlet or the unit's AC socket during a thunder-storm in order to avoid any damage on the unit due to AC voltage peaks.
- In case of not correct function of this unit or damaged AC cord or other damaged parts, pull immediately the AC plug out of the wall outlet and hand the unit over to the authorized service for a security check.
- To meet all aspects of functionality and security during maintenance work to be preformed on this unit, all parts should be replaced by genuine spare parts. Consequently, take care of your dealer or maintenance company to be authorized by the manufacturer.

■ Health advice

This unit produces and absorbs electromagnetic radiation. The strength of radiation and the sensitivity for disturbing interference matches the CE and FCC requirements. A corresponding sign is printed on the backside of the unit. Any change or modification may affect the behavior of the unit concerning electromagnetic radiation, with the CE requirements eventually not to be met any more. The manufacturer takes no responsibility in this case.

■ Functional advice

This unit is immune to the presence of electromagnetic disturbances – both conducted and radiated - up to a certain level. Under peak conditions, the unit is classified to show a "class C" performance criteria and may encounter temporary degradation or loss of function which may need manual help to recover. In such case, disconnect the AC power from the unit and reconnect it again to recover.

■ Environmental advice



This unit is built to conform to the ROHS standards and the WEEE directive 2002/96/EC of the European Parliament and of the Council of the European Union. Under these regulations, the product shall not be discarded into regular garbage at the end of its life, but shall be returned to authorized recycling stations.

■ LED Lifetime advice

LED lifetime is determined by the gradually declining brightness of a LED over time, with a point of 50% brightness reduction marking the defined end of its lifetime. The driving factor of this effect is the heat that the chip inside the LED is exposed to. While a chip may under ideal circumstances reach to more than 100000 hours of lifetime, the real-world lifetime may only be 30000 to 50000 hours or less if the LED is exposed to excessive heat, which can be caused by continuously running all LEDs inside this device at full power and operating the unit in high environmental temperatures. If improving the lifespan expectancy is a priority, take care of providing for lower operational temperatures. This may include forced external cooling and/or the reduction of overall projection intensity.

■ Unpacking

Please check that the box contains the following items, and contact your dealer immediately for replacement if any part is missing:

Main parts: 1 pc. MULTIWALL-GII-HS3049 / HT3024 main unit
1 pc. operation manual

■ Getting started: changing the connectors (only if required)

Your MULTIWALL-GII-HS3049 / HT3024 has been factory-fitted with connectors for both AC In/out and DMX In/Out. This configuration can be changed with comparatively little effort into an IP65-compliant outdoor version, with PG9 cable glands to hold all connection cables in a waterproof manner.



Reliability risk: Changing the connectors in an inappropriate manner may defeat the waterproof capabilities of the fixture and may void any warranty of the manufacturer if water intrudes into the unit. It is essential to follow the below instructions to maintain the waterproof capabilities of the fixture and its product warranty subsequently.



Safety risk: This procedure requires to open the unit. In case of unintended connection to AC supply, life parts may be exposed and touchable. In case of wrong internal wiring, the safety of the whole installation where this unit is used may be endangered and a risk of fire is possible. This procedure shall hence only be carried out by qualified technicians with relevant experience in safe work methods for electrical equipment service and maintenance. DO NOT attempt to change the connectors by yourself if you do not have the applicable experience. The manufacturer does not take any liability for life and assets if such unqualified attempt is made.



set. The same happens if the color is changed by the left/right arrows, in this case the dimming level mode is left immediately and the dimming level will remain as last set.

Note: This mode is intended to offer more color options than the static color mode. It however is not intended to offer more white shades, which means the white channel is not used in the color scroll mode.

■ SWITCH / STROBE PATTERNS

In this mode you will only find hard switching and strobe patterns. Press the MODE button until the display shows "SPxx" whereas xx stands for numbers 0 until 12. The available patterns are defined as follows:

Pattern	Steps	Pattern	Steps
SP0	red-green	SP7	red-green-blue
SP1	blue-green	SP8	yellow-green-turquoise-blue-candy-red
SP2	blue-red	SP9	Strobe red
SP3	yellow-red	SP10	Strobe green
SP4	candy-lime	SP11	Strobe blue
SP5	candy-blue	SP12	Strobe white
SP6	candy-turquoise		

Use the left/right arrows to change the pattern between any of the 13 presets, the display shows "SP0"... "SP12" accordingly and will remain to show unless the speed function is used. Use the +/- button to change the speed level or activate the Sound-to-Light function. The first touch of the + or - button changes the display, now showing the speed level "SL00"... "SL25" or "S2L" representing the following speed levels:

Setting	Speed	Setting	Speed
S2L	Sound-to-Light	SL13	1 step per second
SL1	1 step per 240 seconds	SL14	1,5 steps per second
SL2	1 step per 120 seconds	SL15	2 steps per second
SL3	1 step per 90 seconds	SL16	2,5 steps per second
SL4	1 step per 60 seconds	SL17	3 steps per second
SL5	1 step per 30 seconds	SL18	4 steps per second
SL6	1 step per 20 seconds	SL19	5 steps per second
SL7	1 step per 10 seconds	SL20	6 steps per second
SL8	1 step per 5 seconds	SL21	7 steps per second
SL9	1 step per 3 seconds	SL22	8 steps per second
SL10	1 step per 2 seconds	SL23	9 steps per second
SL11	1 step per 1,6 seconds	SL24	10 steps per second
SL12	1 step per 1,2 seconds	SL25	11 steps per second

Please note that above speed levels are only applicable to patterns SP0....SP08. For the strobe patterns, the following speed table applies:

Setting	Speed
S2L	Beatflash function: one flash per sound trigger (Strobe-to-Sound)

■ STATIC COLOUR

Press the MODE button until the display shows “STxx” whereas xx stands for numbers 0 until 25.

Use the left/right arrows to change the colour between any of the 26 presets, the display shows “ST0”...“ST25” accordingly and will remain to show unless the dim function is used. Use the +/- button to change the dim level. The first touch of the + or - button changes the display, now showing the dimming level “L000”...“L100” representing the relative dimming level chosen. Now the dimming level can be changed by using the +/- buttons. Pressing the +/- buttons for longer than 1 second accelerates the change rate of the displayed value to 3 times. If no further changes are made to the dimming level by the +/- buttons, the display will automatically return to show “STxx” after 5 seconds, and the dimming level will remain as last set. The same happens if the color preset is changed by the left/right arrows, in this case the dimming level mode is left immediately and the dimming level will remain as last set. Color settings for “ST0” ... “ST25” as follows:

Preset #	Color	Preset #	Color
ST0	all off	ST13	Peach
ST1	Red	ST14	Aqua
ST2	Green	ST15	Leaf
ST3	Blue	ST16	Purple
ST4	Yellow	ST17	Barbie
ST5	Pink	ST18	Breeze
ST6	Turquoise	ST19	White 1 (cold)
ST7	Lime	ST20	White 2
ST8	Orange	ST21	White 3
ST9	Marine	ST22	White 4
ST10	Frog	ST23	White 5 (warm)
ST11	Lavender	ST24	Light Orange
ST12	Candy	ST25	Dark Orange

■ COLOUR SCROLL

Press the MODE button until the display shows “Cxxx” whereas xxx stands for numbers 000 until 225. A touch of the left/right arrow buttons will lead to a change of the Colour. Choose your desired colour. The display shows “C0”...“C225” * accordingly and will remain to show unless the dim function is used. Use the +/- button to change the dim level. The first touch of the + or - button changes the display, now showing the dimming level “L000”...“L100” representing the relative dimming level chosen. Now the dimming level can be changed by using the +/- buttons. Pressing the +/- buttons for longer than 1 second accelerates the change rate of the displayed value to 3 times. If no further changes are made to the dimming level by the +/- buttons, the display will automatically return to show “C0”...“C225” after 5 seconds, and the dimming level will remain as last

Before you start to change the connectors, please make sure that:

- yourself or the person in charge has the relevant experience in safe work methods for electrical equipment service and maintenance.
- the unit is disconnected from any AC source. Please note that this also applies to the unit's AC output, since being connected by the AC output to other units which are still under AC supply, will still supply power to the unit.
- the unit is completely dry, and at room temperature.
- the location chosen to exchange the connectors does not have more than 40% relative humidity and the temperature during the exchange does not exceed 40 degrees Celsius. These parameters are important to avoid later condensation of the water contained in the environmental air when the unit works at lower outside temperatures.
- the screw driver used to dismantle and re-assemble the unit is properly matching the screws to avoid any damage to the screws.
- the screw driver has an in-built torque measurement or you have other torque-measurement devices on hand to make sure that screws are fastened with the right torque during re-assembly.

To expedite the connector change, you will need the matching outdoor conversion kit for this unit, which is available from your distributor. Further, you will also need to have the suitable cable material on hand, which ideally is

- Rubber AC cable of at least 3x1.5sqmm cross-section, with outer diameter of not less than 6mm, and not more than 9mm.
- DMX signal cable, 2-wire+shield, with outer diameter of not less than 6mm, and not more than 9mm.
- Matching wire termination sleeves.



Reliability risk: Using cable material of unsuitable outer diameter or with insufficient flexibility of its outer tubing may defeat the waterproof capabilities of the fixture and may void any warranty.

The conversion kit itself contains:

- The outdoor conversion panels (x2)
- The rubber seals for the outdoor conversion panels (x2)
- The PG9 cable glands made from stainless steel (x4)
- The rubber plain washers as seals for the fitting screws (x4)
- The rubber dummy plugs needed if a cable gland remains without cable (x3)

To start expediting the connector change, please follow the below step-by-step instructions and draw your attention to the illustrations provided. Please note that the unit has two connection panels, and each of them will require to expedite the below procedure. Further please note this refers to a conversion from indoor to outdoor; for the inverse conversion, please reverse the procedure's steps 5-16.

- 1) Loosen the 4pcs. of countersunk screws that hold the indoor connection panel on the main unit, and remove the screws.
- 2) Carefully lift the indoor connection panel with the attached connector assembly from the main unit.
- 3) Detach the indoor connection panel far enough from the main unit to gain access to the internal terminal blocks.
- 4) Unscrew the terminal block screws on the connector side and remove the indoor connection panel.
- 5) Pre-assemble the PG9 cable gland body with the outdoor conversion panels. Make sure that the lower PG cable gland seal is fitted properly and that the nut which holds the gland in the outdoor conversion panel is tightened sufficiently. Do NOT yet fit the upper cover nut and the cable seals.
- 6) Put the cover nuts of the PG glands over the cable end and push the cable seals on the cables.
- 7) Insert the cables into the cable gland bodies mounted to the outdoor conversion panels and loosely fix the cover nuts, so that the cable can still be moved longitudinally.
- 8) Pull the cable stubs far enough out to allow skinning of the leads inside the cables.
- 9) Skin the separate leads of both the DMX and AC cables on the rear side of the outdoor conversion panel and terminate them properly with termination sleeves.
- 10) Pull the cables from the front of the outdoor conversion panels until only the skinned individual leads are visible on the rear side of the outdoor conversion panel. Make sure to however not pull the cables too far out; the outer tubing of the cable must still have full-length traction with the cable gland seals.
- 11) Tighten the cover nuts of the PG glands tight enough to make sure the rubber gland seal adapts properly and tightly to the cable's outer perimeter.
- 12) Place the rubber seal for the outdoor conversion panel around the aperture in the main unit.
- 13) Insert the AC leads into the terminal block as indicated on the internal connections chart, and fix the terminal block screws accordingly.
- 14) Insert the DMX leads into the terminal block as indicated on the internal connections chart, and fix the terminal block screws accordingly.
- 15) Insert the outdoor conversion panel into the main body of the unit, making sure that the screw holes are aligned and the rubber seal is properly aligned to the outside perimeter of the outdoor conversion panel.
- 16) Insert the 4pcs. of countersunk screws that hold the outdoor conversion panel to the main unit, and tighten them with 0.6~0.7Nm torque. Note: Before inserting these screws, make sure that each of the is fitted with the provided rubber plain washers, as without these washers, the unit may not be waterproof.

■ Operation

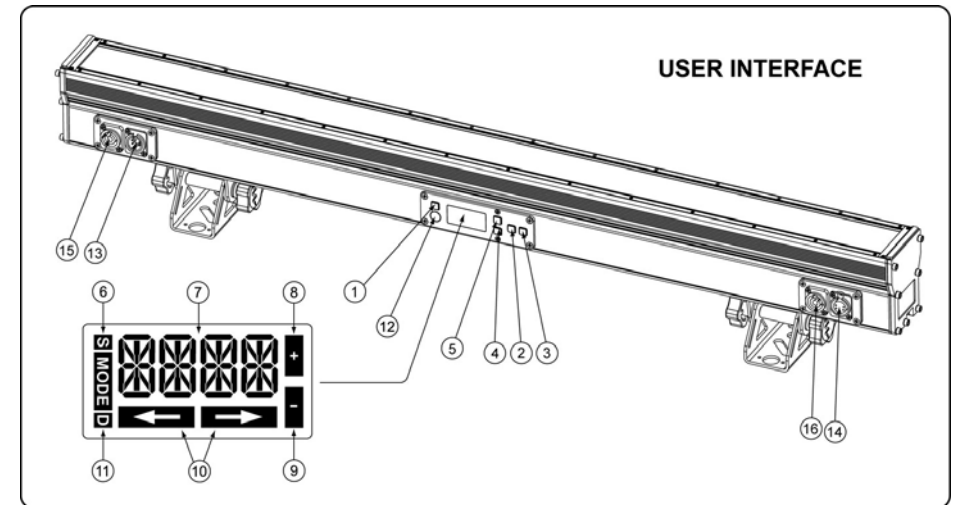

User interface overview:

- 1 MODE selection Button
- 2 LEFT ARROW Button
- 3 RIGHT ARROW Button
- 4 – Button
- 5 + Button
- 6 DISPLAY: Sound-to-Light Indicator
- 7 DISPLAY: 4-Digit Message Display Area
- 8 DISPLAY: + Indicator
- 9 DISPLAY: - Indicator
- 10 DISPLAY: ARROW Indicators
- 11 DISPLAY: DMX Signal Presence Indicator
- 12 Microphone cover membrane
- 13 DMX Input
- 14 DMX Output
- 15 AC Power Input
- 16 AC Power Output
- 17 M6 safety lug mounting thread
- 18 M10 nut insert point

Upon the user's choice, the unit can work in stand-alone automatic mode, or with fixed colors, or it may be controlled by external DMX-controllers. Available modes:

hold 12 times the weight of the device when installing the unit. This secondary safety attachment should be installed in a way that no part of the installation can drop more than 20cm if the main attachment fails.

- Never stand directly below the device when mounting, removing, or servicing the fixture. Make sure the area below the installation place is free from unwanted persons during rigging, de-rigging and servicing.
- The operator has to make sure that the safety-relating and machine-technical installations are approved by an expert before using them for the first time. The installations should be re-inspected every year.
- Make sure to comply with applicable cooling requirements if any.

■ Getting started: making AC supply connections



Risk of fire / Safety risk

- The MULTIWALL-GII-HS3049 / HT3024 requires an AC power source with sufficient power carriage and correct grounding to ensure safe operation. The AC power source must be equipped with a circuit breaker and earth leakage detector. Make sure to only use compliant AC supply lines.
- The MULTIWALL-GII-HS3049 / HT3024 has an AC outlet that is designed to carry loads of no more than 10A. Make sure that all connected devices in a chain fed by the first device do not exceed a maximum of 10A current consumption.

■ Getting started: making DMX control connections

Connect the MULTIWALL-GII-HS3049 / HT3024 to a suitable DMX controller where needed, and interconnect several units by means of their DMX In/Outputs as required. The last unit shall be fitted with a proper 120 Ohm termination resistor-equipped DMX-plug as shown in below drawing. Please make sure that DMX cables comply to below standard:

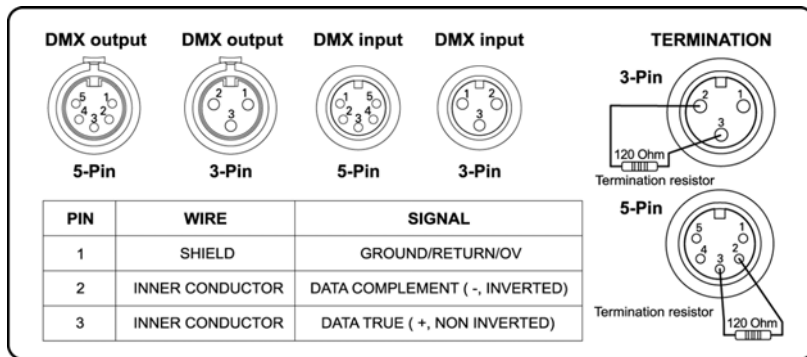

INDOOR/OUTDOOR CONVERSION

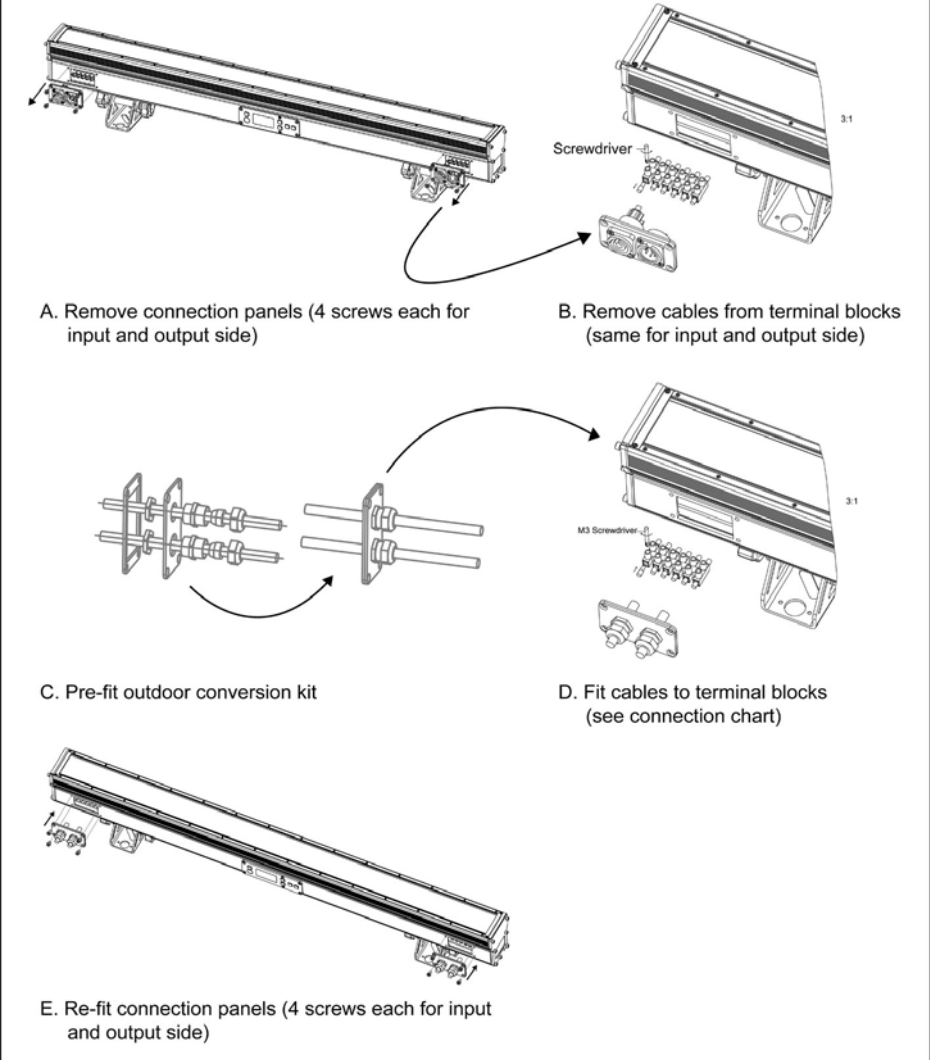

INTERNAL CONNECTIONS

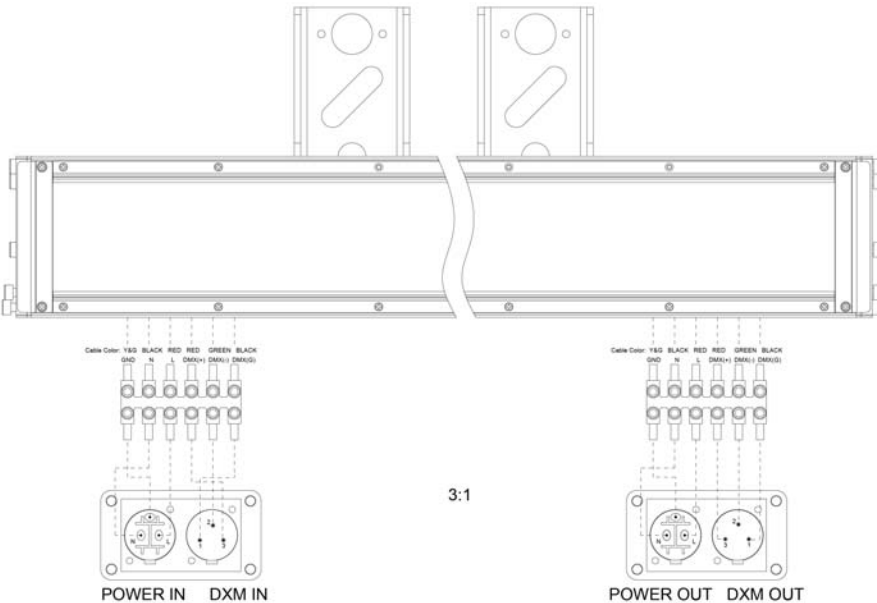

DANGER! Safety hazard.
Risk of severe injury or death.

WARNING! Hazardous voltage.
Risk of lethal or severe electric shock.

NOTE:
Any internal work on this unit shall only be carried out by qualified technicians who are familiar with safe repair techniques. Disconnect AC before opening the unit.

■ Getting started: choosing a location



Risk of fire: The MULTIWALL-GII-HS3049 / HT3024 has been designed for environmental temperatures of up to 40 degrees Celsius. For proper operation, the unit must be operated with unobstructed air convection to its outside metal case.

Do not:

- Operate the MULTIWALL-GII-HS3049 / HT3024 in environments with more than 40 degrees environmental temperature
- Operate the MULTIWALL-GII-HS3049 / HT3024 in any closed environment smaller than 10cbm, unless forced air convection is provided.

■ Getting started: secure mounting

The MULTIWALL-GII-HS3049 / HT3024 can be mounted in various ways:

Floor standing operation

- Turn the brackets on the lower side of the unit in an appropriate position.
- Place the unit in a secure position where it can neither be touched by anyone or could possibly become an objective for anyone to stumble.
- Make sure to comply with cooling requirements if any.

Hanging/Rigging, ceiling/wall-mounted operation



Risk of injury: Overhead or wall-mounting requires extensive experience, including among others calculating working load limits, good knowledge of the installation material being used, and periodic safety inspection of all installation material and the unit. If you lack such qualifications, do not attempt the installation yourself. Improper installation can result in body injury. Be sure to complete all rigging and installation procedures before applying power to the unit.

- Mount appropriate clamps to either the attached brackets or remove the brackets and mount appropriate clamps directly to the M10 screws in the lower nut slot of the unit. Fix the position of the brackets and the clamps tightly. Especially make sure that the M10 screws in the lower nut slot of the unit are fixed tightly so that the unit can not "slide" out of position.
- The unit should be installed out of reach of people and outside areas where persons may walk by or be seated.
- Make sure that the installation area can hold a minimum point load of 10 times the device's weight.
- In fixed installations, fix the unit with self-locking screws/nuts to the mounting point.
- Where required, secure the installation with an appropriate safety cable. Always use a certified safety cable according to EN60598-2-17 Section 17.6.6 that can