

GLAM LASER

PROFESSIONAL LASER

USER MANUAL

Thank you for using our products. For the sake of safety and better operation of this product, please read this manual carefully before using and operating it.

1. GENERAL INSTRUCTIONS

a. UNPACKING

Thank you for purchasing this product. Please read the user guide for safety and operations information before using the product. They contain important information about the security of the facility and on the use and maintenance of equipment.

Keep this manual for future reference. In case of sale of equipment to another user, it is important that this manual is attached to the equipment to the new user has the necessary information to use and can read the warnings on safety.

It is essential that the user duly follows the safety instructions and warnings mentioned in that user manual. The dealer won't be able to be responsible for the defaults or any other problems due to the mishandling from the user and the non following of the instructions included in that user manual.

This product is suitable for creating perfect laser programs and high-quality laser effects.

This unit is designed to produce decorative effect lighting and is used in light show systems.

This product is a so-called show laser emitting radiation with a wavelength spectrum and producing lasers for shows. Please refer to the safety instructions specific for lasers.

Before any first use, unpack the set and make sure there was no damage during transport. Check for missing any part supplied with the laser:

- 1 x GLAM LASER
- 1 x POWER CABLE
- 1 x USER MANUAL

b. GENERAL SAFETY INSTRUCTIONS



This fixture must be earthed to in order to comply with the safety regulations and to avoid any electrical shock.

Before using, please be assure that the voltage is appropriate with the information mentioned at the rear panel of the unit. Ot avoid any shock hazard, do not open or remove the cover.

This unit is designed for indoors use. Do not expose the unit to rain or moisture.

The working temperature of the unit is from 18 to 30°C. Do not use it at higher temperature.

Do not switch on and off many times to avoid reducing the life duration of the fixture.

Do not use the unit for more than 4 hours in order not to decrease the life duration of your fixture.

Always unplug the unit when we do not use it for a long time or before servicing.

Do not place metal objects or spill liquids in/over the unit. If it occurs, please disconnect the unit from the mains at once.

Keep the device away from flammable or hot sources.

The fixture should be placed in a ventilated area and fixed at 50 cm at least from the walls.

Do not cover the ventilation openings as it may result in overheating.

Do not use the unit id dusty environment. Please use soft cloth to remove dust that would be place in the external lens. Clean the unit regularly.

Keep away from children or any non qualified persons.

During the installation of the units, do not let the inexperienced people come around and operate the device.

Make sure that the area below the installation is free from unwanted persons.

The installation should be carried out qualified persons only according to the regulations for safety rules.

Do not remove the stickers placed on the unit. It is forbidden to make any unauthorized modifications to the unit due to safety reasons.

If some parts are visibly damaged (power cord, lens, plug, casing brackets), please do not use the unit and contact your dealer

The unit does not have user serviceable parts inside. Refer to qualified persons or contact your dealer.

Always use parts of same type.

Never repair a fuse or bypass the fuse holder.

Please use the original packaging for transporting the device.

In the event of serious problems, stop using the device contact your dealer. Do not open the cover.

Never look at the light source directly! Do not use the unit effects in the presence of persons suffering from epilepsy.

c. **SAFETY INTRUCTIONS FOR LASERS**

According to EN/IEC 60825-1 regulations, this laser is classified under 3B class. Direct eye exposure can be dangerous



DANGER: LASER RADIATION!

UNIT UNDER 3 B CLASS

AVOID DIRECT EYE EXPOSURE. LASER RADAITION CAN CAUSE EYE DAMAGE AND/OR SKIN DAMAGE

AVOID EXPOSTION TO LASER RADIATION

ALL PROTECTIVE MEASURES MUST BE APPLIED FOR MAKING THE USE OF LASERS SAFE

This product is a so-called show laser emitting radiation with a wavelength spectrum and producing lasers for shows.

A laser (Light Amplification by Stimulated Emission of Radiation) is a device that emits light trough a process of optical amplification and produce electromagnetic radiation of different wavelengths due to the controlled stimulated emissions process.

In addition to the secondary effects due to the operating laser conditions, fire risks or burning hazards, the most important danger comes from the light source. The damages on eyes depend on the laser wavelengths specifications, the eye distance and the elements linked to the eye specifications. This danger is amplifies if the laser beams are focused to tiny spots; that is why the effects on eyes are even more important while using lasers.

3B class can be dangerous under specific conditions

4 class should be ruled under strict safety warnings.

INSTALLATION OF THE UNIT

The units from 3B class and 4 class, exclusively used in open air, should be installed by experienced and qualified professionals, trained to the specific risks of lasers and should handle a user manual.

The area reserved for the public should be limited up to 3 meters above the ground and to 2.5 meters from the public. This zone should be indicated and marked on the ground. In this area, it is not possible to make "pencil beams" (through the output being a narrow beam which is diffraction-limited) in the direction of people, whatever the laser class is, except if a determined area has been defined of 4 meters radius from the public and visibly marked on the ground.

Only laser beams of wavelengths divergence concentrated their power at a large distance are authorized.

OPERATION OF THE UNIT

The use of lasers is out of the reach of people when considering:

- That the unit is situated at 3 meters above the floor at least
- That a safety area is defined within 5 meters radius
- The user takes the responsibility that the units under 3B class or 4 class are mounted by a qualified technician and experienced to the risks of lasers. This technician must stay around during all the time the lasers work and he must be able to stop the units in case some technical problems would occur. While the installation is on, the technician should wear protective glasses.

Please remind the following remarks:

- Laser light is different from any other light source with which you may be familiar. The light from this product can potentially cause eye injury if not set up and used properly.
- Laser light is thousands of times more concentrated than light from any other kind of light source. This concentration can cause instant eye injuries, by burning the retina. Even if you can not feel heat from a laser beam, it can still injure or blind you or the audience.
- Never look at the laser aperture or laser beams.
- Do not direct the laser beam to people.
- Do not leave the device running without the presence of qualified professionals.

EXPELEC can not liable for damages caused by incorrect installations and unskilled operation.

2. SPECIFICATIONS

Voltage : 230V/50Hz

Fuse : 2A/250V

Rated Power : 50W

Scanner : High speed optical scanner, big angle scanning

Laser :

Green 532 nm / 100 mW

Red 650 nm / 200 mW

Purple : 405 nm /200 mw

Working modes : DMX 512 (12 CH), Sound activation, Auto-beam, Auto-animation, Master/Slave, PC control

Graphics & Effects : 256/128 beam show and animated graphics show patterns

Interface 3 pin XLR jack for DMX or Master/Slave linking

Dimensions : 263x 305x 155 mm

Weight : 4.08 kg

3. FEATURES

Animation laser with high optical scanner to create animated graphics, 256/128 beam show and graphics show patterns and with the function of unique blanking, frequently flashing, rotating, moving, split, zoom (+/-), speed and color.

Including 6 working modes as DMX 512, sound active auto-animation, auto-beam, master/slave for different applications

The unit has 14 channels to control in DMX mode. The unit has blackout function. The unit will shut off if no DMX signal.

Design according to performance and security.

Master/Slave mode, DMX 512 mode and PC control mode will shut off laser automatically without trigger signal.

→ FRONT PANEL

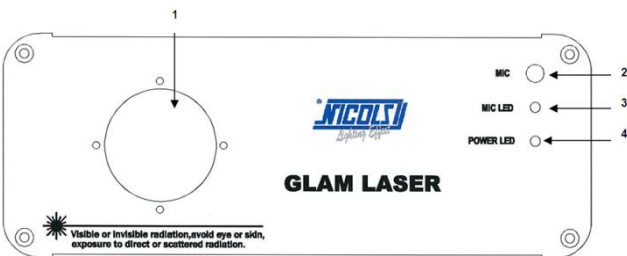

1. Laser aperture
2. Sound active microphone
3. Sound active Indicated : Blue LED
4. Power indicator : Red LED

→ REAR PANEL

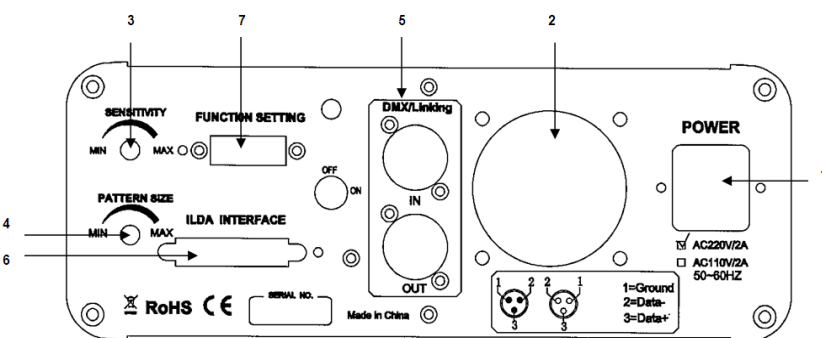

1. Power Jack
2. Cooling Fan
3. Audio sensitivity knob
4. Pattern size knob
5. DMX or linking jack
6. Built-in program or ILDA mode conversion switch
7. Function of built-in program setting dipswitch

4. FUNCTIONS AND SETTINGS

a. FUNCTIONS

i. MUSIC MODE

The change in the shape of the laser is controlled by the music. So, the rhythm of the music controls the effect of changing program of the laser.

ii. AUTO MODE

Auto cycles the built-in programs without being controlled by external sources. It has no laser OFF.

iii. DMX CONTROL

The system only accepts the DMX 512 signal to control the system mode: the laser pattern ON/OFF, the size, the position and the speed.

DMX Control Parameters Chart

Channel	Function	Value	Description
CH1	Mode	0~49	Sound Active mode
		50~99	Auto-Beam mode
		100~149	Auto-Animation mode
		150~199	Manual mode to Auto run
		200~255	Manual mode to Sound Active run
CH2	Dimmer	0~255	AL-100: closed~no blanking~moving blanking~flash blanking~blanking
			AL-600RGY: closed~red~green~yellow~ fixed color~random single color~random three-color~moving three-color~fixed color
CH3	Pattern Select	0~255	256 or 128 patterns
CH4	Moving-Y	0~127	Manual to up to down moving
		128~191	Auto to down moving
		192~255	Auto to up moving
CH5	Moving-X	0~127	Manual to left to right moving
		128~191	Auto to right moving
		192~255	Auto to left moving
CH6	Rolling-X	0~127	Manual rolling
		128~255	Auto rolling
CH7	Rolling-Y	0~127	Manual rolling
		128~255	Auto rolling
CH8	Rotation	0~127	Manual rotation
		128~191	Auto clockwise rotation
		192~255	Auto counter clockwise rotation
CH9	Zoom(+/-)	0~85	Auto zoom(+)
		86~170	Auto zoom(-)
		171~255	Manual zoom(+/-)
CH10	Pattern Size	0~255	0 is Moderate, 1 is small, 255 is big
CH11	Display Dot	0~255	0 is display dot, 255 is best brightness
CH12	Drawing	0~127	Auto drawing mode 1
		128~255	Auto drawing mode 2

FUNCTION SETTINGS

First, setting "Built-in program or ILDA mode switch" to Built-in program or ILDA mode. Second, If it is setting to ILDA mode, then use PC software to control laser light. If the first step setting to Built-in program mode, setting built-in program dipswitches to mode that include SOUND ACTIVE, AUTO, SLAVE mode, see the Built-In Program Function Chart

0 = OFF 1=ON X=OFF or ON

DIPSWITCH CHART										FUNCTION	
#1	#2	#3	#4	#5	#6	#7	#8	#9	#10		
0	0	0	X	X	X	X	X	X	0	SOUND ACTIVE	
1	0	0	X	X	X	X	X	X	0	AUTO-BEAM	
1	1	0	X	X	X	X	X	X	0	AUTO-ANIMATION	
0	0	1	X	X	X	X	X	X	0	SLAVE MODE	
SET DMX ADDRESS										1	DMX MODE

DMX ADDRESS CALCULATION

In DMX mode, the DIP switch from # 1 to # 9 should be set to record a DMX address. The address ranges from 1-511. Each dipswitch represents a binary value. Please refer to table below.

Dipswitch	VALUE	Dipswitch	VALUE
# 1	1	# 6	32
# 2	2	# 7	64
# 3	4	# 8	128
# 4	8	# 9	256
# 5	16	# 10	DMX, on "1"

Each unit has 12 channels. So each product may be receiving a 12-channel DMX address at least. If you assign an address on 16 channels, the DMX address is: $16 * N + 1$, $N=0, 1, 2, 3, \dots$

One loop address=1, two loop address=17, three loop address=33, four loop address=49

Loop	Address	Binary	Dipswitches
1	1	10000000	# 1 (# 1 switch is ON, the others are OFF)
2	17	100010000	# 1+#5 (# 1 and #5 switches are ON)
3	33	100001000	# 1+#6 (# 1 and #6 switches are ON)
4	49	100011000	# 1+#5+#6 (# 1,5,6 switches are ON)

The dipswitches setting for DMX address see the " DMX Address Quick Reference Chart ".

5. OPERATION

a. STAND ALONE OPERATION : Sound activation and AUTO

This mode allows a single device to react to the sound of music.

1. Place the device in a suitable and stable position.
2. Set the dipswitch to select AUTO or Sound active mode.
3. Turn on the unit. The unit resets then it begins to work.
4. The unit will react to low frequencies through the internal microphone. Adjust the sound sensitivity with the appropriate knob located at the rear of the unit. The LED indicates whether the music mode is activated.

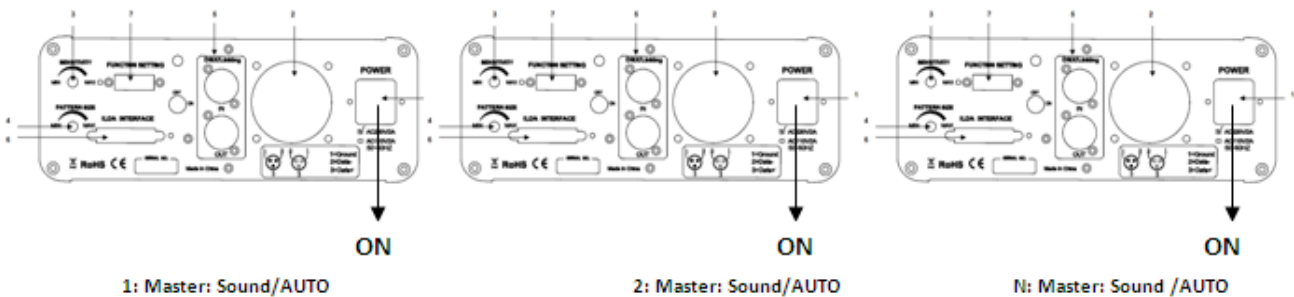

b. MASTER / SLAVE MODE

This mode allows you to connect up to many together without controller.

1. Install the unit in a suitable and stable position.
2. Choose a unit to function as master mode, set dipswitch to select AUTO or Sound active mode. The others must be set in slave mode. Set the DIP switch to slave mode.
3. Use an XLR cable to connect devices together. Taken at the rear of the unit.
4. Turn on all units. The devices reset and then begin to work. The slave units will react the same as the master unit.
5. The units respond to low frequencies through the internal microphone. Adjust the sound sensitivity with the appropriate knob located at the rear of the unit. The LED indicates whether the music mode is activated.

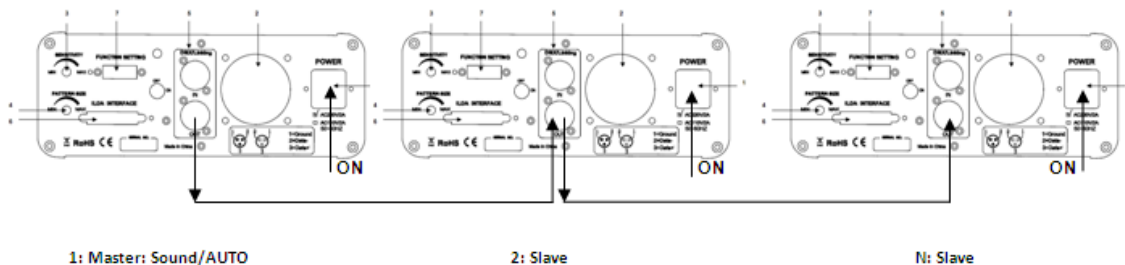

c. UNIVERSAL DMX MODE

This mode allows you to use the DMX 512 console to operate your devices.

1. Install the unit in a suitable and stable position.
2. Use an XLR cable to connect devices together. Taken at the rear of the unit
3. Assign a DMX address for each device using the DIP switch. Please refer to the chart on the last page.
4. Turn on all devices. The units reset, then begin to start working.
5. Use a DMX console to control your devices.

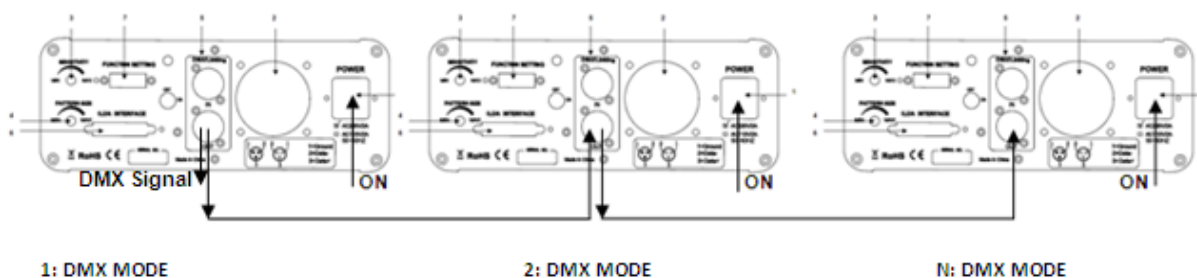

NOTE:

1. DMX console can not be operated in Master / Slave (AUTO / SOUND ACTIVE mode)
2. There must be only 1 single master unit in Master / Slave mode

6. TROUBLESHOOTING

1. If the power indicator does not lit up and the device does not work, please check the power cable is properly connected and if the input voltage is compatible with that of the device.
2. In Stand alone operation, if the power indicator lights up and sound active indicator does not lit up and the light beam does not work.
 - a. The sound is too low. Increase the volume of music or sound sensitivity.
 - b. Check if the device is in slave mode then set up in master mode.
3. In Master / Slave mode, the slave units does not work
 - a. Make sure there is only 1 single unit in the master channel and the other units are set as a slave.
 - b. Make sure you are not using a DMX console
 - c. Make sure the cables are of good quality and the connections are properly made.
4. In DMX mode, the beam does not work and the DMX signal is off.
 - a. Make sure the DMX mode is activated.
 - b. Make sure the cables are of good quality and the connections are properly made.
5. In DMX mode, the laser is not controlled by the DMX console, DMX signal indicator flashes. Make sure the console and the units have the same channel.
6. If the direction of the beam is not correct, restart the machine.
7. If the unit does not work properly, turn the unit off then back on.

If the unit meets other operational problems, we recommend that you contact your dealer.

TABLE SET DMX ADDRESS

DMX:DIPSWITCH SET					#9	0	0	0	0	0	0	0	0	1	1	1	1	1	1	1	1
0=OFF					#8	0	0	0	0	1	1	1	1	0	0	0	0	1	1	1	1
1=ON					#7	0	0	1	1	0	0	1	1	0	0	1	1	0	0	1	1
X=OFF or ON					#6	0	1	0	1	0	1	0	1	0	1	0	1	0	1	0	1
#1	#2	#3	#4	#5																	
0	0	0	0	0		32	64	96	128	160	192	224	256	288	320	352	384	416	448	480	
1	0	0	0	0	1	33	65	97	129	161	193	225	257	289	321	353	385	417	449	481	
0	1	0	0	0	2	34	66	98	130	162	194	226	258	290	322	354	386	418	450	482	
1	1	0	0	0	3	35	67	99	131	163	195	227	259	291	323	355	387	419	451	483	
0	0	1	0	0	4	36	68	100	132	164	196	228	260	292	324	356	388	420	452	484	
1	0	1	0	0	5	37	69	101	133	165	197	229	261	293	325	357	389	421	453	485	
0	1	1	0	0	6	38	70	102	134	166	198	230	262	294	326	358	390	422	454	486	
1	1	1	0	0	7	39	71	103	135	167	199	231	263	295	327	359	391	423	455	487	
0	0	0	1	0	8	40	72	104	136	168	200	232	264	296	328	360	392	424	456	488	
1	0	0	1	0	9	41	73	105	137	169	201	233	265	297	329	361	393	425	457	489	
0	1	0	1	0	10	42	74	106	138	170	202	234	266	298	330	362	394	426	458	490	
1	1	0	1	0	11	43	75	107	139	171	203	235	267	299	331	363	395	427	459	491	
0	0	1	1	0	12	44	76	108	140	172	204	236	268	300	332	364	396	428	460	492	
1	0	1	1	0	13	45	77	109	141	173	205	237	269	301	333	365	397	429	461	493	
0	1	1	1	0	14	46	78	110	142	174	206	238	270	302	334	366	398	430	462	494	
1	1	1	1	0	15	47	79	111	143	175	207	239	271	303	335	367	399	431	463	495	
0	0	0	0	1	16	48	80	112	144	176	208	240	272	304	336	368	400	432	464	496	
1	0	0	0	1	17	49	81	113	145	177	209	241	273	305	337	369	401	433	465	497	
0	1	0	0	1	18	50	82	114	146	178	210	242	274	306	338	370	402	434	466	498	
1	1	0	0	1	19	51	83	115	147	179	211	243	275	307	339	371	403	435	467	499	
0	0	1	0	1	20	52	84	116	148	180	212	244	276	308	340	372	404	436	468	500	
1	0	1	0	1	21	53	85	117	149	181	213	245	277	309	341	373	405	437	469	501	
0	1	1	0	1	22	54	86	118	150	182	214	246	278	310	342	374	406	438	470	502	
1	1	1	0	1	23	55	87	119	151	183	215	247	279	311	343	375	407	439	471	503	
0	0	0	1	1	24	56	88	120	152	184	216	248	280	312	344	376	408	440	472	504	
1	0	0	1	1	25	57	89	121	153	185	217	249	281	313	345	377	409	441	473	505	
0	1	0	1	1	26	58	90	122	154	186	218	250	282	314	346	378	410	442	474	506	
1	1	0	1	1	27	59	91	123	155	187	219	251	283	315	347	379	411	443	475	507	
0	0	1	1	1	28	60	92	124	156	188	220	252	284	316	348	380	412	444	476	508	
1	0	1	1	1	29	61	93	125	157	189	221	253	285	317	349	381	413	445	477	509	
0	1	1	1	1	30	62	94	126	158	190	222	254	286	318	350	382	414	446	478	510	
1	1	1	1	1	31	63	95	127	159	191	223	255	287	319	351	383	415	447	479	511	

