

USER MANUAL

RevA 06-2017

DMP-230 V2

Media Player | FM Tuner | BT Option

Welcome

Thank you for choosing Hill Audio for your sound system. To make sure that this product meets your expectations and provides long-term, reliable performance, please read and follow this instruction manual carefully.

Manual Language

UK	This user manual is written in English. For other languages, visit	www.hill-audio.com
FR	Ce guide est écrit en anglais. Pour les autres langues, visitez:	www.hill-audio.com
DE	Diese Anleitung ist in Englisch verfasst. Für andere Sprachen:	www.hill-audio.com
ES	Este manual está escrito en Inglés. Para otros idiomas, visite:	www.hill-audio.com
PT	Este manual está escrito em Inglês. Para outros idiomas, visite:	www.hill-audio.com
IT	Questo manuale è scritto in inglese. Per altre lingue, visitare:	www.hill-audio.com

Important safety instructions

- Read these instructions and all markings on the product. Keep these instructions.
- Heed all warnings and instructions, both in this manual and on the product.
- Clean only with a dry cloth. Unplug from AC supply before cleaning.
- Do not use this product near water and avoid any exposure to water.
- Before connecting this product to any AC supply, make sure you check whether the AC mains voltage and frequency match the indication on the product and its packaging.
- Only connect this product to an AC supply with sufficient power handling, protective earth connection, ground-fault (earth-fault) protection and overload protection.
- Disconnect the product from the AC supply during thunderstorms. Also disconnect from the mains supply if the product is not being used for long periods.
- Make sure any heat sink or other cooling surface, or any air convection slot, is exposed sufficiently to free air circulation and is not blocked.
- Do not operate this product in environmental temperatures exceeding 35 degrees Celsius and/or 85% relative humidity.
- Position the product in a safe and stable place for operation, out of reach of unauthorized persons.
- Make sure any cable connections to and from the product are neither subject to potentially destructive mechanical impact nor present any risk of stumbling or other accident risk to people.
- Audio equipment may generate sound pressure levels sufficient to cause permanent hearing damage to persons. Always start up at low volume settings and avoid prolonged exposure to sound pressure levels exceeding 90 dB.
- Do not open this product for service purposes. There are no user-serviceable parts inside. Warranty will be void in any case of unauthorized service by the user or other unauthorized persons.
- Take any precaution required by local law, applicable regulations or good business practice to avoid injury to people or material damage by use of this product.

Explanation of symbols used in this manual and on the product:



ATTENTION!
Read manual before installation and operation.



DANGER!
Safety hazard.
Risk of injury or death.



WARNING!
Hazardous voltage.
Risk of severe or fatal electric shock.



WARNING!
Fire hazard.

Description

The DMP-230V2 Media Player + FM Tuner is a music player for background music systems, with Bluetooth available optionally.

Health advice

This unit produces and absorbs electromagnetic radiation. The strength of radiation and the sensitivity for disturbing interference matches the CE and FCC requirements. A corresponding sign is printed on the backside of the unit. Any change or modification may affect the behavior of the unit concerning electromagnetic radiation and it may not then meet CE requirements. The manufacturer takes no responsibility in this case.

Functional advice

This unit is immune to the presence of electromagnetic disturbances – both conducted and radiated - up to a certain level. Under peak conditions, the unit is classified to show a “class C” performance criteria and may encounter temporary degradation or loss of function which may need manual help to recover. In such case, disconnect the AC power from the unit and reconnect it again to recover.

Environmental advice

This unit is built to conform to the ROHS standards and the WEEE directive 2002/96/EC of the European Parliament and of the Council of the European Union. Under these regulations, the product shall not be discarded into regular garbage at the end of its life, but shall be returned to authorized recycling stations.

Unpacking

Please check that the box contains the following items:

- Main parts:
- 1 pc. DMP-230V2 or DMP-230V2B main unit
 - 1 pc. Mains cable
 - 1 pc. FM antenna adaptor
 - 1 pc. Bluetooth antenna (for versions fitted with BT receiver)
 - 1 pc. Operation manual

If any part is missing, please contact your dealer immediately.

Warning

After unpacking, and before plugging the AC cord in the wall outlet, check whether the AC mains voltage and frequency is compatible with this product (see rear panel of product). Whenever the specified voltage or your AC plug should not match the local conditions, do NOT plug the AC cord into the wall outlet and contact your dealer.

AC mains voltage setting

If the AC mains voltage of your power outlet and the setting of the AC supply voltage on your unit do not match, contact your dealer or contractor to change the setting of the AC voltage selector. The AC voltage selector switch is located on the right side panel of the unit, under the plastic side cheek. The side cheeks can be removed after loosening the 4 screws as shown, and pulling the side cheek off.

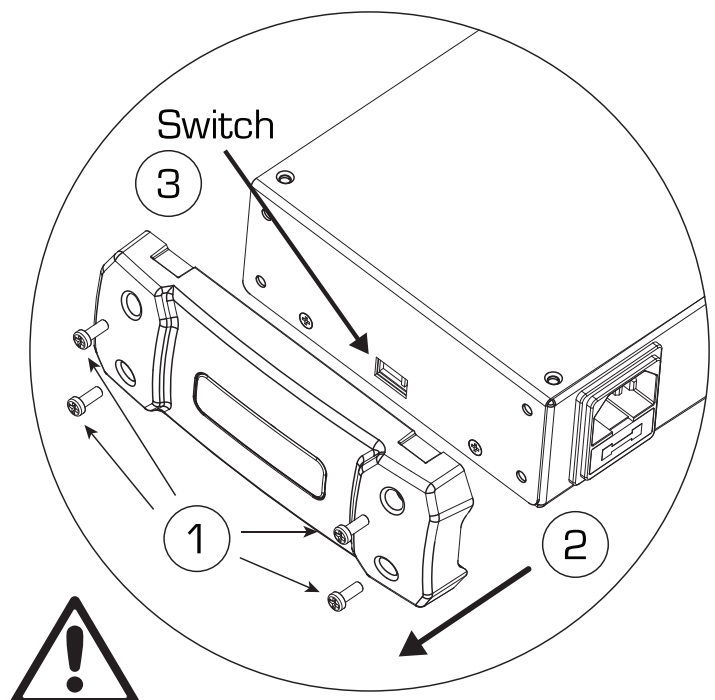

Controls and Connections

Connections - Rear

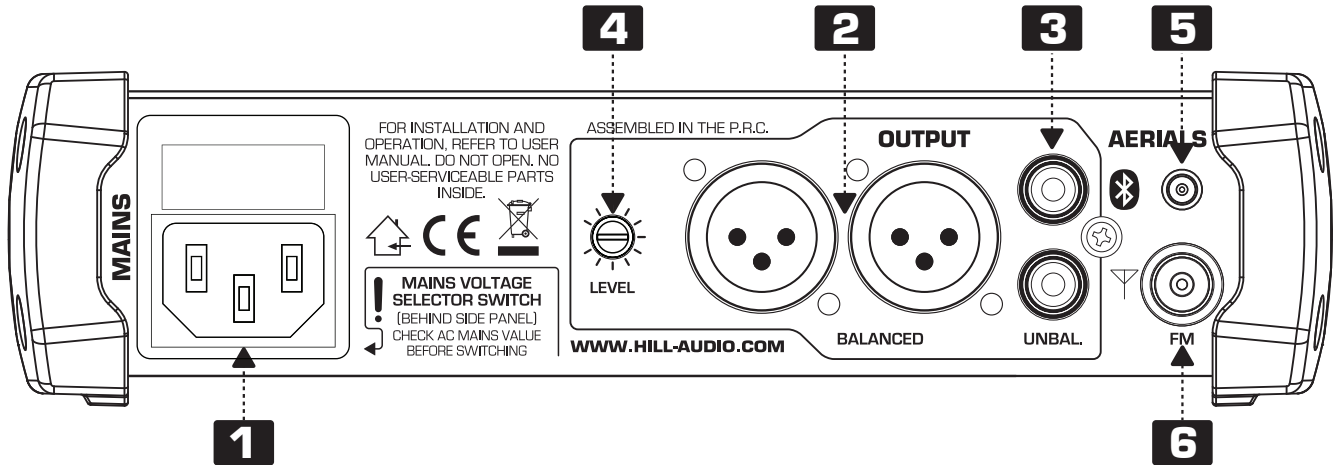

Controls - Front

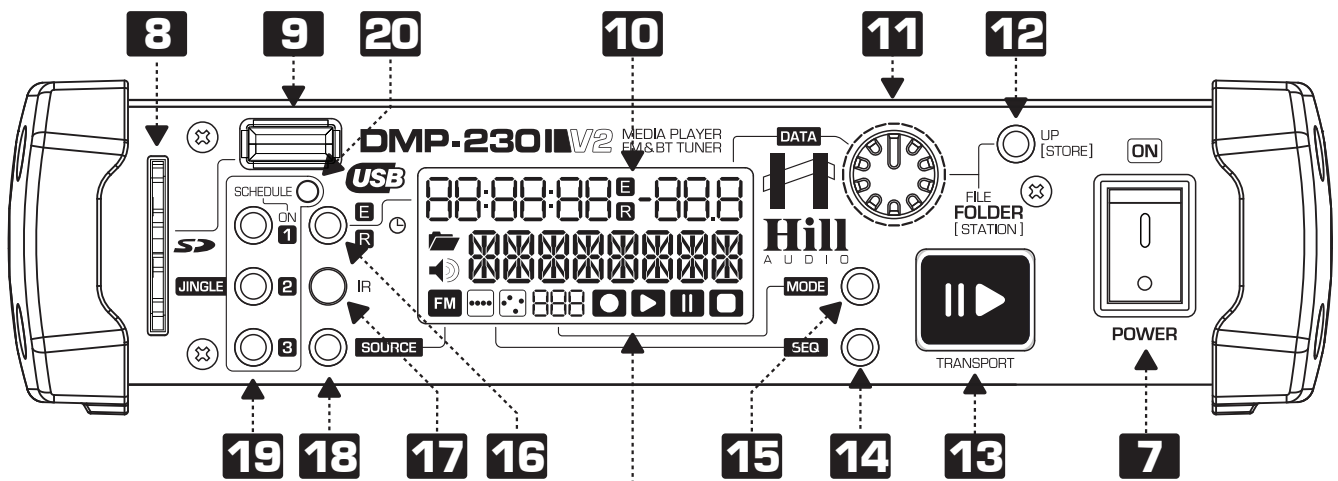

Display - Elements

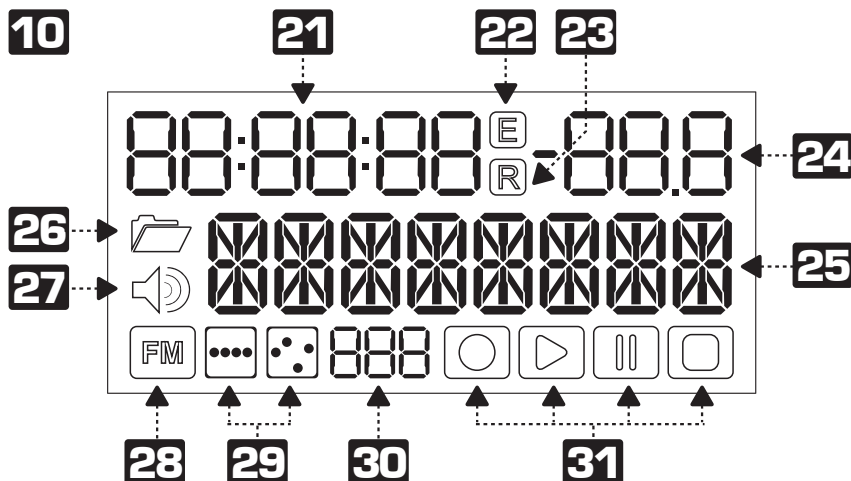

Remote Control - Elements

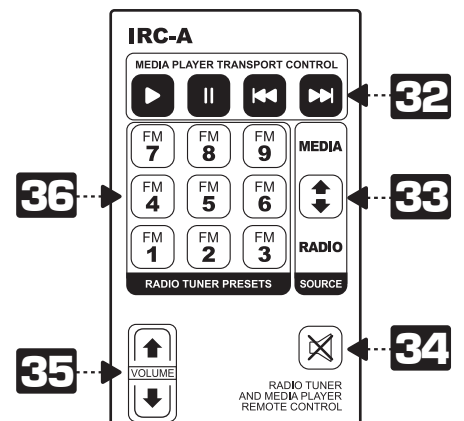

Functional Description

The DMP-230V2 is a media player with built-in FM radio tuner and 3-jingle spot announcer, allowing replay of MP3 files from a solid-state USB memory. Media navigation is facilitated by file name read-out on a clear-text display. As a second source a FM radio tuner with RDS station readout is built in; a Bluetooth receiver is optionally available as a 3rd source. A jingle player / spot announcer allows you to insert jingles or adverts either on the spot or via pre-programmed schedule.

- 1** AC inlet. Use the supplied AC cord to connect the unit to AC mains. Make sure voltage and frequency stated and set on the unit comply with your local AC supply. Note that this unit does not have an exposed AC mains fuse. Replacement of the internal AC mains fuse requires you to hand over the unit to qualified service personnel.
- 2** Stereo Main output. This is a balanced stereo XLR output.
- 3** Stereo Main output. This is an unbalanced RCA output carrying the same signal as output (3).
- 4** Maximum level setting for Stereo Main output. This control allows you to limit the maximum level at the outputs (3)/(4) in order to match the connected sound system. Adjustments shall be made with a small screwdriver. Note that the total angle is 300 degrees; do not apply excessive force with the screwdriver.
- 5** Bluetooth Antenna socket. Plug in the supplied BT antenna here (only versions with optional BT receiver)
- 6** Aerial socket. Plug in a dedicated FM antenna here, or connect any suitable antenna cable of the house installation here (75 Ohms cable).
- 7** Power switch. Switches the unit on and off. Make sure you switch the unit off when not in use.
- 8** SD Card slot. Insert a FAT32-formatted SD card of max 16GB with a one-level folder structure for replay of MP3 files here. If both a USB memory stick is inserted into (9), and an SD card is inserted in (8), the last inserted media will be given priority.
- 9** USB memory socket. Insert a FAT32-formatted USB memory stick of max 16GB with a one-level folder structure for replay of MP3 files here. If both a USB memory stick is inserted into (9), and an SD card is inserted in (8), the last inserted media will be given priority. Note: this socket does NOT support USB hard drives, both for memory size and power requirements.
- 10** Media player display. Shows track/folder information, time information, play status, replay mode settings and play sequence settings. Details are described under items (21...31)
- 11** Data dial. Depending on the chosen source (FM or Media - via control 18), this control has different functionality:
In Media Play mode (Indicator 28 off) | Turn: choose a song/folder, Press: activate the choice.
In FM Mode: (Indicator 28 on) Press: choose between frequency scroll or station preset scroll, Turn: choose frequency or station. The choice is immediately active.
- 12** Folder level (Store) button. Depending on the chosen source (FM or Media - via control 18), this control has different functionality:
In Media Play mode (Indicator 28 off) | Press: go to folder level, then navigate by data dial (11)
In FM Mode: (Indicator 28 on) | Allows you to store a new station preset. Choose frequency scroll mode by pressing (11) if required. Press the Folder Level (Store) button (12) once to display the station preset you wish to store the frequency at. Choose the preset by turning (11) and confirm by pressing the Folder level (Store) button (12) again, the station is now stored at the chosen preset.

- 13** Media PLAY/PAUSE/STOP button. Press briefly to toggle between PLAY (backlight continuously lit) and PAUSE (backlight flashing) mode. Press for longer than 2 seconds to change into STOP status (backlight off). Restart by pressing the button again, this will commence replay from the last known position when having been in PAUSE mode or from the start of the chosen track when being in STOP mode. This control is inactive in FM mode. The selected status is displayed in the display [31]
- 14** Play sequence selector. Selects between
Straight play sequence: The next song is determined by alphanumerical sorting. The left sequence mode indicator is lit in the display [29].
Random play sequence: The next song is determined by random choice. The right sequence mode indicator is lit in the display [29].
This control is inactive in FM mode.
- 15** Play mode selector. Selects between
SPL = Single Play. The player stops after playing the current song once. The next song is manually chosen by [11] and determined by the chosen play sequence.
SLO = Single Loop. The player loops the current song endlessly. The next song is manually chosen by [11] and is determined by the chosen play sequence.
ACO = All Continuous. The player continues after the playing the current song. The next song is determined by the chosen sequence. The player stops after the sequence is executed once.
ALO = All Loop. The player continues after the playing the current song. The next song is determined by the chosen sequence. The player repeats the sequence endlessly.
Those chosen play mode is displayed in the display [30]. This control is inactive in FM mode.
- 16** Time Display selector. Selects between elapsed/remaining time display. The time display choice is shown in the display [22] and is always related to track currently playing. This control is inactive in FM mode.
- 17** IR Receiver sensor. If using the included IR remote control, make sure an unobstructed line of sight is available between the remote control and the IR receiver sensor.
- 18** SOURCE button. Toggles the program source between Media play and FM Tuner. If FM Tuner is chosen as the program source, the display's FM Mode indicator [28] is lit while the media replay related indicators [29/30/31] are disabled. Further the media replay related user interface elements [13/14/15] are disabled and the functional assignment of the navigation controls [11/12] is changed. In versions with built-in Bluetooth receiver, the SOURCE button toggles between MediaPlay / FM Tuner / Bluetooth. The Bluetooth selection is indicated by the display's text section [25] showing "AUX-BT" with all other display elements disabled. See chapter "Bluetooth replay" for further information.
- 19** JINGLE buttons. Provided that the inserted media contains a folder named "Jingles" in its root directory, and that the files in this folder follow certain naming conventions, up to 3 of these files can be activated by the buttons [19]. When a jingle is activated, the current program is muted and the jingle is played instead; however, the program progresses in the background. Jingles can be played both in Media play mode and FM mode. A further scheduled jingle play mode is available by pressing the J1 (jingle 1) button for longer than 2 seconds, the LED [20] will indicate that the scheduled jingle play mode is active. To de-activate the scheduled jingle pay mode, press the J1 button again for more than 2 seconds. For more details, please see the "Jingle player" chapter.
- 20** Scheduled Jingle Play Mode Indicator. This LED is lit when the scheduled jingle play mode has been activated by pressing the J1 button for longer then 2 seconds.

Display Elements

- 21** Time Display. Depending on the chosen source (FM or Media - via control 18), this part of the display shows different content:
In Media Play mode (Indicator 28 off): Either the remaining or elapsed time are displayed in a hh:mm:ss format, depending on the setting made by [16].
In FM Mode: (Indicator 28 on): If the unit works in station scroll mode, the currently chosen station preset number is displayed. If the unit works in frequency scroll mode, this part of the display remains unused (blank).
- 22** Time Mode Display (Elapsed): In Media play mode, this part of the display indicates that the elapsed time of the current track is shown in the time display [21]. The setting can be altered by [16]. This part of the display remains unused in FM mode.
- 23** Time Mode Display (Remaining): In Media play mode, this part of the display indicates that the remaining time of the current track is shown in the time display [21]. The setting can be altered by [16]. This part of the display remains unused in FM mode.
- 24** Numeric data display. This part of the display is not used in this product. This is NOT a malfunction.
- 25** 8-Digit Clear Text Readout. Depending on the chosen source (FM or Media - via control 18), this part of the display shows different content:
In Media Play mode (Indicator 28 off): The file name of the currently playing track is shown, with its first 30 digits scrolling through the display. Letters exceeding 30 digits will be discarded. Note that this is NOT an ID3 tag readout, but a file name readout, so files must be named properly to yield a sensible displayed content. The display will show the file name and alternate with the folder name the current file is located in. Whether at a specific time the file or the folder name is displayed, is indicated by the respective symbols [26/27].
In FM Mode: (Indicator 28 on): The RDS station name (PS section of the RDS signal) is displayed if the received FM signal contains this information. If no RDS station name is available, the currently tuned frequency is displayed. Note that this unit only displays the station name of the RDS signal, no other potentially contained RDS content.
- 26** Folder Name Display Indicator. In Media play mode, this indicator shows that the current content of the Clear text readout [25] is a folder name. This indicator is not used in FM mode.
- 27** File Name Display Indicator. In Media play mode, this indicator shows the current content of the Clear text readout [25] is a file name. This indicator is not used in FM mode.
- 28** Source Mode Indicator. Shows whether unit is in Media play mode (indicator off) or FM mode (indicator on). The mode can be changed via the control [18].
- 29** Play Sequence Indicator. In Media play mode, this indicator shows whether the unit is set to straight sequential or random play sequence. The setting can be altered by control [14]. This indicator is not used in FM mode.
- 30** Play Mode Indicator. Based on the selection made by control [15], this part of the display shows the letters "SPL", "SLO", "ACO" or "ALO". This indicator is not used in FM mode.
- 31** Transport status indicators. In Media play mode, 3 standard symbols indicate whether the unit is in PLAY, PAUSE or STOP status. The 1st (outmost left) indicator is not used in this product; this is NOT a malfunction.

Remote Control Elements

The DMP-230V2 includes an IR (infrared) remote control. For proper operation, a line of sight between the remote control and the sensor on the DMP-230V2 (17) is required. The IR remote does only control the basic functions of the DMP-230V2 and as such adds convenience to the operation, but does not replace the front panel control on the unit itself.

- 32** Transport Controls. In Media play mode, the 4 transport control buttons allow you to start and pause a track, and further skip to the next track or back to the beginning of the current track. These controls are inactive in FM mode.
- 33** Source button. Toggles the program source between Media play and FM Tuner. If FM Tuner is chosen as the program source, the display's FM Mode indicator (28) is lit while the media replay related indicators (29/30/31) are disabled. Further, the media replay related user interface elements (13/14/15) are disabled and the functional assignment of the navigation controls (11/12) is changed.
- 34** Mute button. Toggles between muted and un-muted output of the DMP-230V2.
- 35** Volume control (up/down). Allows you to set the required audio volume.
- 36** FM preset station buttons. Allows to remotely activate the stored FM station presets in the DMP-230V2. These buttons only work in FM mode and are disabled in Media play mode. Note that manual tuning via the IR remote control is not possible,

Notes on files, folders and data conventions

The DMP-230V2 is a hardware player and as such subject to various restrictions, which are useful to be aware of:

- Media Memory types. The DMP-230V2 only works with SD cards and USB sticks up to 16GB of size which are formatted in FAT32 file system and contain a maximum of 2000 files. The DMP-230V2 does NOT support larger memory sizes, external HDD's or media with NTFS formatting.
- Media File types. The DMP-230V2's replay ability from solid state memory media is limited to MP3 files in MPEG 1 Layer 3, MPEG 2 Layer 3, MPEG 2.5 Layer 3 standard, with sample rates of 128/160/192/224/256/320 kbps + VBR. Any other files existing on the solid state memory media will be ignored and are not available for replay.
- File/Folder Structure. The DMP-230V2 only allows a two-layer folder structure on the solid state media memory, meaning a root layer and a folder layer, but not any cascaded folder-in-folder structures. Such subfolders will be ignored and their content is not available for replay. Playable files located in the root layer are displayed in a folder named "ROOT" although this folder does not physically exist on the solid state memory media.
- Folder Sorting. Folders are displayed in the sequence of their creation dates on the solid state memory media. If a specific sequence is needed, then the folder shall be created in this sequence on the memory media before copying any MP3 files into them.
- File Sorting. Files are sorted alphanumerically, but due to file system limitations, the sorting is limited to the first 8 digits. This may in some cases - where the first 8 digits are identical - lead to a random-looking, not alphabetical sorting sequence of files.
- File system cache. In order to allow relatively quick access to the file directory during navigation, the DMP-230V2 loads a copy of the file directory into its own memory upon insertion of the solid state memory media. This loading process requires some time, during which the display shows a countdown. The time required is about 4 seconds per 100 tracks with a maximum of 2000 tracks (meaning Max. 80 seconds loading time).
- Displayed File/Folder names. MP3 files are displayed with the first 30 digits of their file names in a scrolling manner; digits exceeding the first 30 will be ignored. Note that the display data is the file name and NOT the ID3 tag of the file. Folders are displayed with the first 10 digits of their names, any exceeding digits will be ignored.

Jingle Player

The DMP-230V2 contains a Jingle player with a one-shot mode for teasers and a scheduled mode for commercial purposes (like playing advertisements in a certain sequence). To make use of the feature, the user must create a folder named “Jingles” on the solid state memory media. The folder must have exactly this name (with capital J and lower case following letters) and will not be available for choice during normal replay.

The jingle files stored in this folder have to be prepared with specific names as well, and have to follow the structure jx_yy with x from 1...3 and yy from 00 to 99. In this format, x defines the jingle number (with a maximum of 3 jingles allowed) and yy being the number of minutes of background music the jingle is followed by in scheduled jingle play mode. As an example, three jingles could be named j1_01.mp3, j2_04.mp3 and j3_05.mp3. These three jingles will then be available for direct one-shot play on pressing the jingle buttons (19), with each jingle assigned to the relative button.

A scheduled jingle play mode can be activated by pressing the J1 button for longer than 2 seconds, allowing the jingles to be inserted into the program in an automatic sequence with a certain duration of background music in between. The jingle replay would in the above example start immediately with Jingle 1 followed by 1 minute of background music, then Jingle 2 followed by 4 minutes of background music, then jingle 3 followed by 5 minutes of background music; after this, the sequence would loop. If less jingles are stored in the Jingles folder, the loop runs after the last available jingle. As another example, if only one jingle named j1_02 is stored in the Jingles folder, then this would mean the jingle would play every 2 minutes in scheduled jingle play mode.

Bluetooth Replay (only versions with built-in BT receiver)

The DMP-230V2 is optionally available with built-in Bluetooth module (version DMP-230V2B). This module can not be retrofitted and the availability of the Bluetooth-enabled version might be subject to territorial restrictions.

To connect a Bluetooth source like a smartphone or tablet to the DMP-230V2B, follow the below procedure:

- Press the SOURCE button (18) until the display shows “AUX-BT”
- Activate BT on the source device (phone, tablet)
- Search / (Scan) for Devices on the source device
- Select "Bluetooth Board" and confirm connection request
- Wait for single beep from the DMP-230V2B
- The devices are now paired the the DMP-230V2B is ready to receive audio via BT

Note: Only one device can connect - once a device is connected, the BT board will not appear on the device scan of any other device.

To disconnect, simply do the following:

- Tap on existing BT connection in your source device
- Wait for dual-tone beep from the DMP-230V2B
- The devices are now unpaired and the DMP-230V2B is ready to be paired with a different device.

Please note that the maximum distance of operation between your source device and the DMP-230V2B depends on many factors, such as other interfering signals, the position of the DMP-230V2B in the room, the position of the source device in the room, and the antenna/bluetooth hardware design of the source device. While Bluetooth shall work as a rule-of-thumb up to 10m distance, certain hardware combinations, geometrical setups or the presence of interfering signals can reduce this significantly. The manufacturer of this device does not grant any specific operating distance and cannot take any liability for dropouts. For critical applications, we recommend to avoid wireless replay.

Operation

A. Connections

For connecting this unit to AC mains, please note:

- Check whether the AC mains voltage and frequency is the same as this product is specified for (see rear panel of product). Whenever the specified voltage or your AC plug does not match the local conditions, do NOT plug the AC cord into the wall outlet and contact your dealer immediately.
- Do not operate this unit without the line cord earth ground connected. To do so may increase the risk of electric shock and increase line cord conducted emissions.

For making audio signal connections, always remember that good and reliable connections are a basic requirement for good sound and reliable operation. Bad soldering of cables can result in intermittent audio signals or temporarily lost ground connections, hence always use good cables. If you are doubtful about making proper connections, please see check the standard pin assignments required for proper operation in the following section of this manual.

B. Powering up

Following a proper power-up sequence protects your equipment, specifically speakers (and your ears). Follow the below procedure:

- Turn down all output volume controls of any equipment in your audio system.
- Switch on your audio sources first (Tuners, CD Players, PC's with soundcards, Tapedecks, etc.)
- Switch on the audio mixer
- Switch on any audio processor between the mixer and the amplifier(s) [if any].
- Switch on the amplifier(s).
- Turn up the audio level on your sources if such controls are provided.
- Set the audio output of your mixer to a low level.
- Set the audio output of any audio processor between the mixer and the amplifier(s) to a medium level [if any such processors].
- Turn up the volume controls of your amplifier(s) slowly.
- Make adjustments to all volume settings as needed.

For switching off, follow the inverse sequence – always switch off your amplifier(s) first, then any processors between mixer and amplifier(s), then the mixer, then the sources.

D. General Advice

Apart from using good equipment, good sound comes from using it correctly. Level setting mistakes are one of the common reasons why even good equipment may not perform as desired. For setting levels, please be reminded that two guidelines need to be followed:

- Avoid distortion by leaving some headroom. Never overrun any audio-equipment's inputs. Level meters and displays allow you to make sure that signals do not enter critical levels.
- Avoid unnecessary amplification by using as little attenuation as possible.

Obviously, these two requirements are marking a leveling window that the operator must match to achieve a good sound with as little distortion and noise as possible.





WARNING - HEALTH RISK

Excessive volume levels on headphones or other sound systems may cause hearing damage. Always turn the volume control to minimum when you switch the unit on, and avoid prolonged exposure to sound pressure levels exceeding 90dB.

Connections

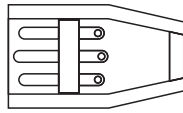
The DMP-230V2 uses the connection types shown below. The pin convention must be followed. Always make sure to use good connectors and cables to ensure proper operation. Balanced connections are to be preferred over unbalanced connections where applicable and feasible. Avoid unbalanced connections exceeding 2m of cable length.

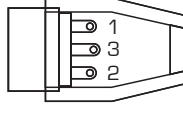
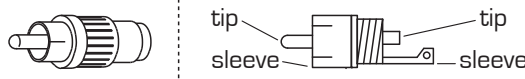
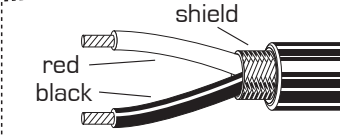
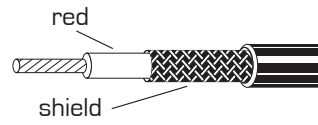
	Structure		Balanced connection	Unbalanced connection
XLR male			red = 2 black = 3 shield = 1	red = 2 shield = 1+3
XLR female			red = 2 black = 3 shield = 1	red = 2 shield = 1+3
RCA			red = tip black = sleeve shield = uncon.	red = tip shield = sleeve
CABLE Types				
	2-conductor shielded cable (for balanced connections)		1-conductor shielded cable (for unbalanced connections)	

Technical Specifications

Audio formats (local replay):.....MP3	Dimensions.....W195.0×H50.0×D131.0mm
AC IN115V/230~ 50/60Hz	(with plastic side cheeks)
Power consumption.....max. 10W	W180.0×H42.0×D114.2mm
	(without plastic side cheeks)
	Weight.....0.90 kg

Maintenance and warranty

While we have chosen the best components to make this product as rugged and reliable as possible, some parts in audio products (potentiometers, faders, switches) are subject to wear which is a matter of operation cycles, and not of time. While providing a full time-based warranty according to the country's of purchase requirements on the function of the electronic circuitry, we hence have to limit the warranty on such electro-mechanical parts to 90 days from the date of purchase.

In many cases, malfunction of electro-mechanical parts occurs due to dust contamination, which may require cleaning of such parts. As the inside of such parts is not accessible, a common practice is to use cleaning fluids in the shape of sprays. Please be reminded that many of such fluids contain chemicals which may wash away the dust but at the same time corrode or damage contact surface and may cause cosmetic damage to other parts. We hence explicitly exclude any claims for exchange of damaged part due to mechanical or chemical impact.

EC Declaration of Conformity

Manufacturer: Adelto Technologies Limited
Address: Unit 2A Springfield Road, Springfield Industrial Estate
Burnham-on-Crouch, Essex CM08UA, England

We declare on our own responsibility, that the equipment

Hill Audio DMP-230V2
Hill Audio DMP-230V2B

is in conformity with the following directives and standards or regulations:

EMC Directive 2014/30/EU
EN55032:2012 (Emissions)
EN55103-2:2009 (Immunity)
EN61000-3-2:2014
EN61000-3-3:2013

LVD Directive 2014/35/EU
EN60065:2014

ROHS2 Directive 2011/65/EU

and is marked as follows:



Burnham-on-Crouch, 30.06.2017
Place and date of issuing

Authorized Signature

www.hill-audio.com



Hill Audio products are developed, manufactured and distributed by
Adelto Technologies

Unit 2A Springfield Road, Springfield Industrial Estate, Burnham-on-Crouch, Essex CM08UA, England
www.adelto.com | sales@adelto.com