

USER MANUAL

RevA 06-2017

RPQ-2150

DUAL 15-BAND EQUALIZER

Welcome

Thank you for choosing Hill Audio for your sound system. To make sure that this product meets your expectations and provides long-term, reliable performance, please read and follow this instruction manual carefully.

Manual Language

| | | |
|----|--|--|
| UK | This user manual is written in English. For other languages, visit | www.hill-audio.com |
| FR | Ce guide est écrit en anglais. Pour les autres langues, visitez: | www.hill-audio.com |
| DE | Diese Anleitung ist in Englisch verfasst. Für andere Sprachen: | www.hill-audio.com |
| ES | Este manual está escrito en Inglés. Para otros idiomas, visite: | www.hill-audio.com |
| PT | Este manual está escrito em Inglês. Para outros idiomas, visite: | www.hill-audio.com |
| IT | Questo manuale è scritto in inglese. Per altre lingue, visitare: | www.hill-audio.com |

Important safety instructions

- Read these instructions and all markings on the product. Keep these instructions.
- Heed all warnings and instructions, both in this manual and on the product.
- Clean only with a dry cloth. Unplug from AC supply before cleaning.
- Do not use this product near water and avoid any exposure to water.
- Before connecting this product to any AC supply, make sure to check whether the AC mains voltage and frequency match the indication on the product and its packaging.
- Only connect this product to an AC supply with sufficient power handling, protective earth connection, ground-fault (earth-fault) protection and overload protection.
- Disconnect the product from the AC supply during thunderstorms or longer periods of being unused.
- Make sure any heat sink or other cooling surface, or any air convection slot, is exposed sufficiently to free air circulation and is not blocked.
- Do not operate this product in environmental temperatures exceeding 35 degrees Celsius and/or 85% relative humidity.
- Position the product in a safe and stable place for operation, out of reach of unauthorized persons.
- Make sure any cable connections to and from the product are neither subject to potentially destructive mechanical impact nor present any risk of stumbling or other accident risk to people.
- Audio equipment may generate sound pressure levels sufficient to cause permanent hearing damage to persons. Always start up at low volume settings and avoid prolonged exposure to sound pressure levels exceeding 90 dB.
- Do not open this product for service purposes. There are no user-serviceable parts inside. Warranty will be void in any case of unauthorized service by the user or other not authorized persons.
- Take any precaution required by local law, applicable regulations or good business practice to avoid injury of people or material damage by use of this product.

Explanation of symbols used in this manual and on the product:



ATTENTION!
Read manual before installation and operation.



DANGER!
Safety hazard.
Risk of injury or death.



WARNING!
Hazardous voltage.
Risk of severe or fatal electric shock.



WARNING!
Fire hazard.

Description

The RPQ-2150 is a stereo 15-band EQ with additional adjustable active subwoofer crossover. It sports a PeakID system helping to identify energy peaks in the audio spectrum, thus facilitating the reduction of feedback danger. Low Cut Filters and level meters for the inputs, as well as a Mute function for the outputs complete the features and make this units a versatile tool for any sound system.

Health advice

This unit produces and absorbs electromagnetic radiation. The strength of radiation and the sensitivity for disturbing interference matches the CE and FCC requirements. A corresponding sign is printed on the backside of the unit. Any change or modification may affect the behavior of the unit concerning electromagnetic radiation, with the CE requirements eventually not to be met any more. The manufacturer takes no responsibility in this case.

Functional advice

This unit is immune to the presence of electromagnetic disturbances – both conducted and radiated - up to a certain level. Under peak conditions, the unit is classified to show a “class C” performance criteria and may encounter temporary degradation or loss of function which may need manual help to recover. In such case, disconnect the AC power from the unit and reconnect it again to recover.

Environmental advice

This unit is built to conform to the ROHS standards and the WEEE directive 2002/96/EC of the European Parliament and of the Council of the European Union. Under these regulations, the product shall not be discarded into regular garbage at the end of its life, but shall be returned to authorized recycling stations.

Unpacking

Please check that the box contains the following items:

Main parts: 1 pc. RPQ-2150 main unit
 1 pc. Mains cable
 1 pc. Operation manual

If any part is missing, please contact your dealer immediately for replacement.

Warning



After unpacking, and before plugging the AC cord in the wall outlet, check whether the AC mains voltage and frequency is the same as this product is specified for (see rear panel of product). Whenever the specified voltage or your AC plug should not match the local conditions, do NOT plug the AC cord into the wall outlet and contact your dealer immediately.

AC mains voltage setting

If the AC mains voltage of your power outlet and the setting of the AC supply voltage on your unit do not match, contact your dealer, contractor or a qualified service workshop to change the setting of the AC voltage selector. The AC voltage selector switch is located on the side panel of the unit, close to the AC inlet.

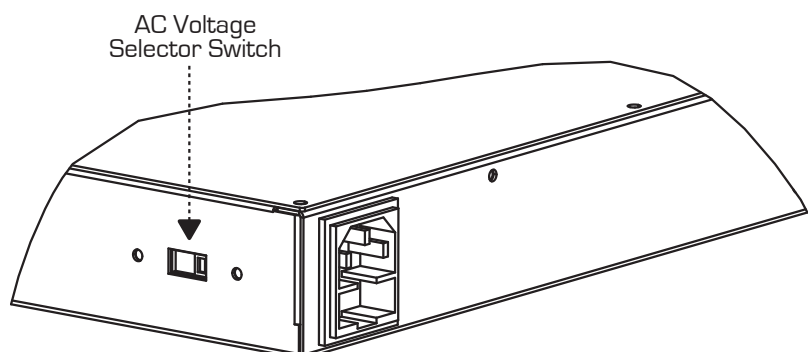

Controls and Connections

Connections - Rear

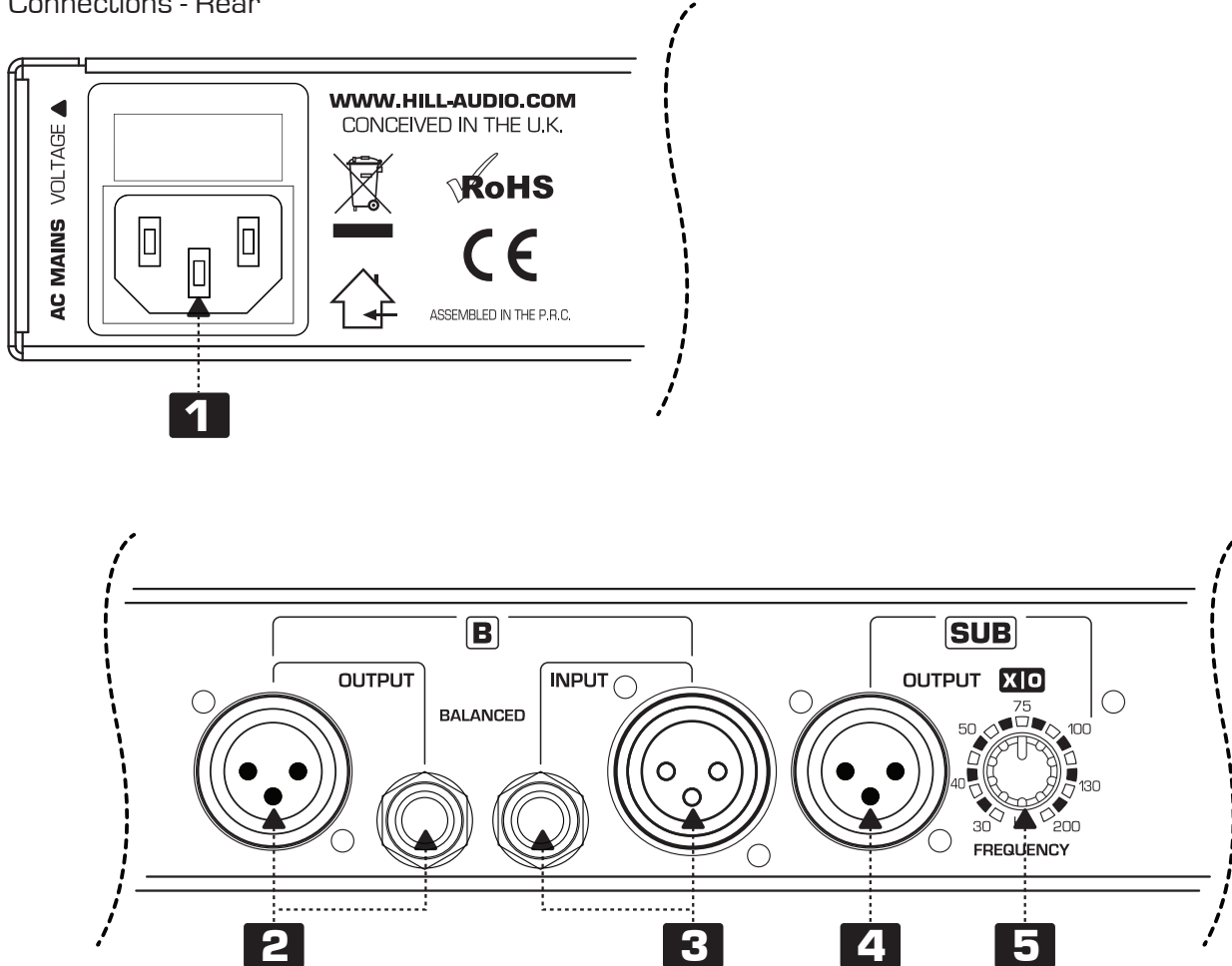

Controls - Front

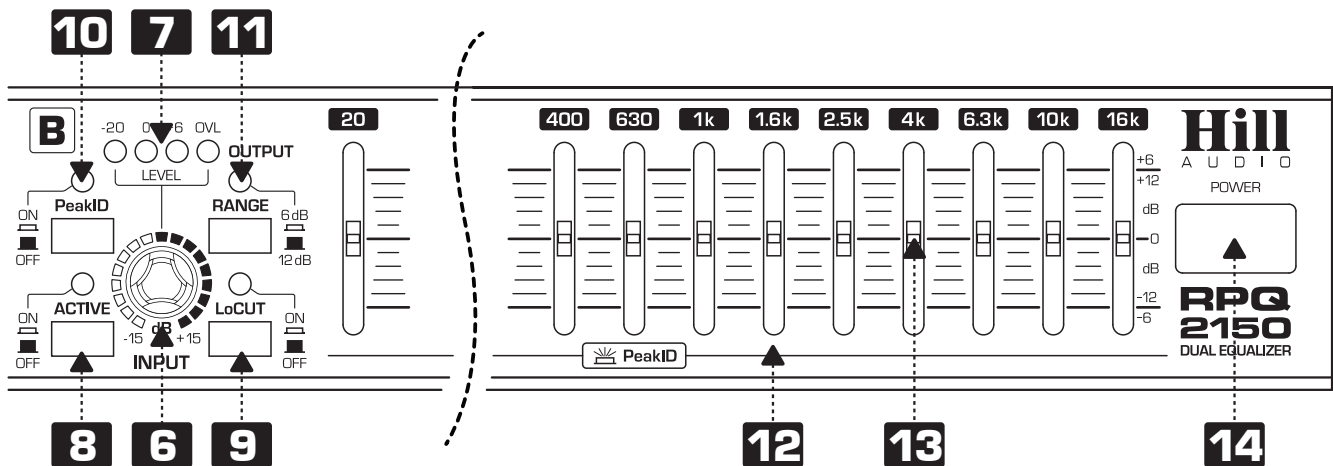



Functional Description

The RPQ-2150 is a 2x15-Band stereo graphic equalizer with additional built-in active subwoofer crossover with adjustable frequency. It sports a switchable 6/12dB range, a PeakID system for feedback alert, switchable 25Hz Low-Cut filters and individual output level meters for each channel.

- 1** AC inlet and fuse holder. Use the supplied AC cord to connect the unit to AC mains. Make sure voltage and frequency stated and set on the unit comply with your local AC supply. The fuse can be accessed by the small drawer at the AC inlet. To change the fuse, unplug the AC cord first, pull out the fuse drawer and replace the fuse **ONLY** with a fuse of **SAME** voltage and rating. If the fuse blows again after replacement, hand over the unit to qualified service personnel.
- 2** OUTPUT connectors (channel A and B). These are both balanced XLR and TRS connectors in parallel. Connect following devices of your sound system (amplifiers, etc) here.
- 3** INPUT connectors (channel A and B). These are both balanced XLR and TRS connectors in parallel. Connect preceding devices of your sound system (mixers, etc) here.
- 4** SUBWOOFER OUTPUT connector. This is a balanced XLR output for the mono subwoofer signal. The crossover frequency is determined by the rear-panel frequency control [5].
- 5** SUBWOOFER XOVER FREQUENCY control (for both channel A and B). This control sets the crossover frequency between the mono subwoofer and the stereo mid/high frequency outputs of channel A and B [2]. The frequency can be adjusted from 30 to 200Hz.
- 6** INPUT control. This adjusts the input signal level in a range of +15 to -15 dB. A LED indicates the status.
- 7** LEVEL meter. Displays the output level at connectors [2] in 3 steps from -20 to +6dB. An overload LED indicates when the +18dB limit is reached.
- 8** ACTIVE switch. This enables or disables the entire equalizer section. As long as the switch is not depressed or while the equalizer is not powered up, the EQ circuit is bypassed. This can also help to compare the original unprocessed signal with the processed signal. A LED indicates the status.
- 9** LoCUT switch. This switch activates the 25 Hz high-pass filter with a 12 dB/Octave slope for protection against infrasonic signals. A LED indicates the status.
- 10** PeakID switch. Pressing this switch activates the PeakID system, which shows by means of LEDs in the relative frequency band's fader shaft where the acoustic energy is located in the audio spectrum. An illuminated fader LED hence indicates a peak in energy, and can help to identify a feedback and reduce the same by lowering this fader. A LED indicates the status.
- 11** RANGE switch. This alternates between the maximum value of boosting/attenuating of individual frequencies from 12 dB to 6 dB (switch depressed).
- 12** FREQUENCY CONTROLS. These are 15 sliding controls per channel for individual frequency bands. In the middle position, the particular frequency range is not processed; moving upwards creates a boost, moving downwards attenuation. While boosting frequencies, observe the output level [7] to avoid clipping.
- 13** PeakID LEDs. These indicate the signal level of their particular frequency ranges through their varying illumination intensity, helping to identify energy peaks and thus possible feedback.
- 14** POWER switch. Switches the unit on and off. Make sure to switch the unit off when not in use.

Connections

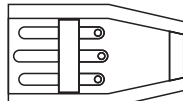
The RPQ-2150 uses the below connector types, for which the pin assignment must comply with the following specification. Always make sure to use good connectors and cables to ensure proper operation. Balanced connections are to be preferred over unbalanced connections where applicable and feasible. Avoid unbalanced connections exceeding 2m of cable length.

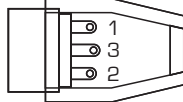
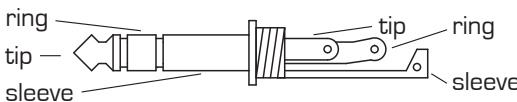
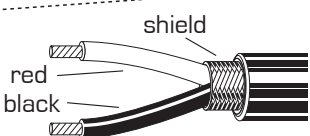
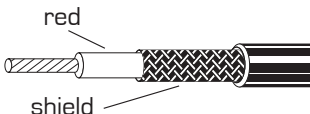
| | Structure | | Balanced connection | Unbalanced connection |
|--------------------------|--|---|---|-----------------------------------|
| XLR male |  |  | red = 2 black = 3 shield = 1 | red = 2 shield = 1+3 |
| XLR female |  |  | red = 2 black = 3 shield = 1 | red = 2 shield = 1+3 |
| 6.35mm TRS-stereo |  | | red = tip black = ring shield = sleeve | red = tip shield = sleeve+ring |
| CABLE Types |  | |  | |
| | 2-conductor shielded cable (for balanced connections) | | 1-conductor shielded cable (for unbalanced connections) | |

Technical Specifications

Signal/Noise.....>92dB (unwgt'd 22Hz-22KHz)
 Crosstalk Damping.....>65dB
 THD.....<0.01% (Line)
 Frequency response.....20Hz – 20 kHz
 AC IN.....AC115V/230V~ 50/60Hz

Power consumption.....max. 20W
 Dimensions.....W483(427)xH44.5xD162.0mm
 (parentheses = without rack ears)
 Weight.....2.30kg

Maintenance and warranty

While we have chosen the best components to make this product as rugged and reliable as possible, some parts in audio products (potentiometers, faders, switches) are subject to wear which is a matter of operation cycles, and not of time. While providing a full time-based warranty according to the country's of purchase requirements on the function of the electronic circuitry, we hence have to limit the warranty on such electro-mechanical parts to 90 days from the date of purchase.

In many cases, malfunction of electro-mechanical parts occurs due to dust contamination, which may require cleaning of such parts. As the inside of such parts is not accessible, a common practice is to use cleaning fluids in the shape of sprays. Please be reminded that many of such fluids contain chemicals which may wash away the dust but at the same time corrode or damage contact surface and may cause cosmetic damage to other parts. We hence explicitly exclude any claims for exchange of damaged part due to mechanical or chemical impact.

Operation

A. Connections

For connecting this unit to AC mains, please note:

- Check whether the AC mains voltage and frequency is the same as this product is specified for (see rear panel of product). Whenever the specified voltage or your AC plug should not match the local conditions, do NOT plug the AC cord into the wall outlet and contact your dealer immediately.
- Do not operate this unit without the line cord earth ground connected. To do so may increase the risk of electric shock and increase line cord conducted emissions.

For making audio signal connections, always remember that good and reliable connections are a basic requirement for good sound and reliable operation. Bad soldering of cables can result in intermittent audio signals or temporarily lost ground connections, hence always use good cables. In case of doubt about making proper connections, please see check the standard pin assignments required for proper operation in the following section of this manual.

B. Powering up

Following a proper power-up sequence protects your equipment – specifically speakers – and your ears. Follow the below procedure:

- Turn down all output volume controls of any equipment in your audio system.
- Switch on your audio sources first (Tuners, CD Players, PC's with soundcards, Tapedecks, etc.)
- Switch on the audio mixer
- Switch on any audio processor between the mixer and the amplifier(s) [if any].
- Switch on the amplifier(s).
- Turn up the audio level on your sources if such controls are provided.
- Set the audio output of your mixer to a low level.
- Set the audio output of any audio processor between the mixer and the amplifier(s) to a medium level [if any such processors].
- Turn up the volume controls of your amplifier(s) slowly.
- Make adjustments to all volume settings as needed.

For switching off, follow the inverse sequence – always switch off your amplifier(s) first, then any processors between mixer and amplifier(s), then the mixer, then the sources.

C. Use

Apart from using good equipment, good sound comes from using it correctly. Level setting mistakes are one of the common reasons why even good equipment may not perform as desired. For setting levels, please be reminded that two guidelines need to be followed:

- Avoid distortion by leaving some headroom. Never overrun any audio-equipment's inputs. Level meters and displays allow you to make sure that signals do not enter critical levels.
- Avoid unnecessary amplification by using as little attenuation as possible. For example, if you turn down the input gain of a mixer to minimum, and then increase the main output of the mixer to maximum to drive your amplifier properly, you will create unnecessary noise, as you first dispose of some already existing signal level, and then later apply amplification (tainted with noise) to make it up.

Obviously, these two requirements are marking a levelling window that the operator must match to achieve a good sound with as little distortion and noise as possible.



WARNING - HEALTH RISK

Excessive volume levels on headphones or other sound systems may cause hearing damage. Always turn the volume control to minimum when you switch the unit on, and avoid prolonged exposure to sound pressure levels exceeding 90dB.

EC Declaration of Conformity

Manufacturer: Adelto Technologies Limited
Address: Unit 2A Springfield Road, Springfield Industrial Estate
Burnham-on-Crouch, Essex CM08UA, England

We declare on our own responsibility, that the equipment

Hill Audio RPQ-2150

is in conformity with the following directives and standards or regulations:

EMC Directive 2014/30/EU
EN55032:2012 (Emissions)
EN55103-2:2009 (Immunity)
EN61000-3-2:2014
EN61000-3-3:2013

LVD Directive 2014/35/EU
EN60065:2014

ROHS2 Directive 2011/65/EU

and is marked as follows:



Burnham-on-Crouch, 30.06.2017
Place and date of issuing

Authorized Signature

www.hill-audio.com



Hill Audio products are developed, manufactured and distributed by
Adelto Technologies

Unit 2A Springfield Road, Springfield Industrial Estate, Burnham-on-Crouch, Essex CM08UA, England
www.adelto.com | sales@adelto.com