

AMERICAN AUDIO®

UCD-200

Professional Dual CD/USB Player

USER MANUAL

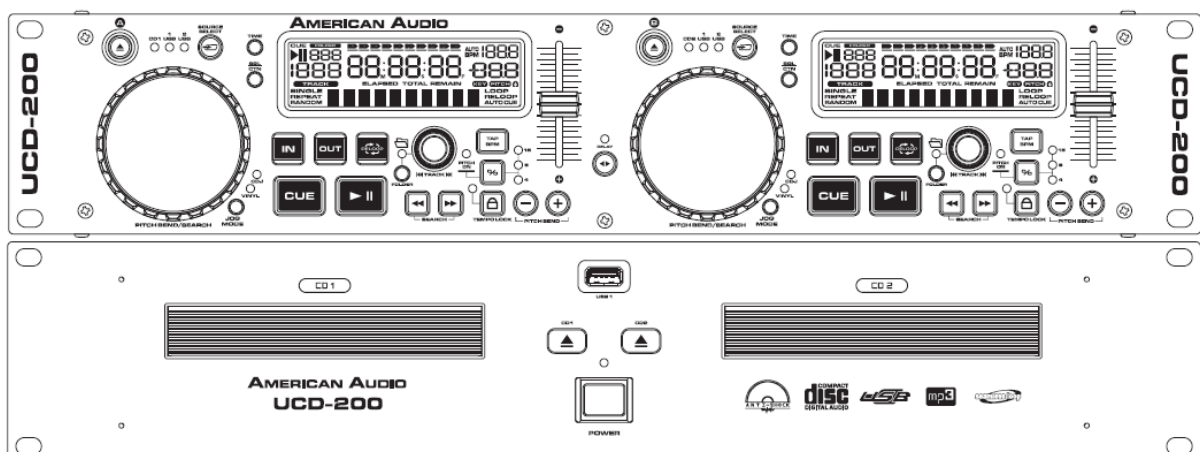

FOR BEST CD-R DISC PLAYBACK RESULTS IN THIS CD PLAYER PLEASE FOLLOW THESE GUIDE LINES:

1. High quality CD-R Audio discs (should conform to the standards of the Orange Book 2).
2. Use a high quality bit rate when recording discs. (At least 160kbps)
3. Record discs in the slowest speed possible. (i.e. 2x or 4x speed)

***Please Note:** All specifications and improvements to and in the design of this unit and this manual are subject to change at any time without any prior written or published noticed.*

For service parts visit <http://parts.americandj.com>

AMERICAN AUDIO®
6122 S. Eastern Ave
Los Angeles Ca. 90040
www.americanaudio.eu

TABLE OF CONTENT

Safety Precautions	6
Important Safety Instructions	9
Product Information	12
General Information	12
Cleaning Information	12
Customer Support	13
Set-Up	14
Checking the Contents	14
Installing the Units	14
Connections	14
Main Features	15
SD CARD Information	16
USB Information	16
Functions and Controls	17
Remote Control – Front Controls	17
Remote Control – Rear Controls	20
Player Unit – Face	21
Player Unit – Rear	22
Liquid Crystal Display (LCD)	22
Internal Menu	25
Basic Operation	27
Opening and Closing the Disc Tray	27
Loading Discs	27
Loading USB Device	28
Selecting Your Audio Source	28

Selecting Tracks	28
Starting Playback	28
Stopping Playback.....	29
Setting Cue Points.....	29
Changing the Time Display (37) / Timebar (36).....	29
Time Bar Indicator	29
Pitch Adjustments.....	30
Using the Pitch Slider Percentage Selector (8).....	30
Activating the Pitch Slider (5)	30
Using the Pitch Slider (5)	31
Pitch Bend.....	31
(+) Pitch Bend button (13)	31
(-) Pitch Bend button (13).....	31
Jog Wheel (19).....	32
Creating and Playing a Loop	32
Loop Editing	33
Flip-Flop (Relay) Connection and Setup	34
RELAY (FLIP-FLOP™).....	34
Database Builder (PC Only)	35
Minimum Hardware Requirements.....	35
Installation.....	35
Open Database Builder.....	36
How to format your memory device	37
How to create a database file.....	38
Possible Errors	38
Set Up	39

Troubleshooting	40
Disc Read Error	40
USB device not reading	40
Music files not found in USB device or Database.....	40
File Error when building DB file.....	40
Before Switching off the Power.....	41
Compact Disc.....	42
Precautions on Handling Compact Discs.....	42
Precaution on Storage	42
ROHS – A Great Contribution to the Conservation of Environment	43
WEEE – Waste of Electrical and Electronic Equipment	44
Specifications.....	45
General	45
Audio Section.....	45
Audio Characteristics.....	46
Searching Time	46
Playability	47
Pick-Up.....	47
MP3 Format.....	47

SAFETY PRECAUTIONS



The lightning flash with an arrow triangular symbol is intended to alert the user to the presence of non-insulated “dangerous voltage” within the product’s enclosure, and may be of sufficient magnitude to constitute a risk of electric shock.



The exclamation point triangular symbol is intended to alert the user to the presence of important operating and maintenance (servicing) instructions in the user manual accompanying the unit.



	<p style="text-align: center;">CAUTION</p> <p style="text-align: center;">RISK OF ELECTRIC SHOCK! DO NOT OPEN!</p> <p style="text-align: center;">TO REDUCE THE RISK OF ELECTRIC SHOCK, DO NOT REMOVE THE COVER (OR BACK). THERE ARE NO USER SERVICEABLE PARTS INSIDE. REFER SERVICE TO YOUR AUTHORIZED AMERICAN AUDIO® SERVICE TECHNICIAN.</p>	
--	---	--

	<p>Please carefully read and understand the instructions in this manual thoroughly before attempting to operate this unit. These instructions contain important safety information regarding the use and maintenance of this unit. Take special care to follow all warning symbols and labels both on the unit and printed in this manual. Also, Please keep this manual with the unit, for future reference.</p>
--	---

CAUTION:

- Handle the power supply cord carefully. Do not damage or deform; it may cause electric shock or malfunction when used. Hold plug attachment when removing from wall outlet. Do not pull on the cord.
- To avoid electric shock, do not open the top cover when the unit is plugged in. If problems occur with the unit, call your local American Audio® dealer.

- Do not place metal objects or spill liquid inside the unit. Electric shock or malfunction may occur.
- The serial and model number for this unit is located on the rear panel. Please write down the numbers here and retain for future reference.
 - Model No. _____
 - Serial No. _____

	<p>CAUTION:</p> <p>TO PREVENT ELECTRIC SHOCK DO NOT USE THIS (POLARIZED) PLUG WITH AN EXTENSION CORD, RECEPTACLE OR OTHER OUTLET UNLESS THE BLADES CAN BE CAREFULLY INSERTED TO PREVENT BLADE EXPOSURE!</p>	
---	--	---

CAUTION:

- USE OF CONTROLS OR ADJUSTMENTS OTHER THAN THOSE SPECIFIED HEREIN MAY RESULT IN HAZARDOUS RADIATION EXPOSURE
- THE DEVICE SHOULD NOT BE ADJUSTED OR REPAIRED BY ANYONE EXCEPT PROPERLY QUALIFIED SERVICE PERSONNEL.

<p>NOTE:</p> <p>This product satisfies FCC regulations when shielded cables and connectors are used to connect the unit to other equipment. To prevent electromagnetic interference with electrical appliances such as radios and televisions, use shielded cables and connectors for connections.</p>	<p>NOTE:</p> <p>This device uses a semiconductor laser. It is recommended for use in a room at the following temperature: 41° - 95°F or 5°C - 35°C.</p>
---	--

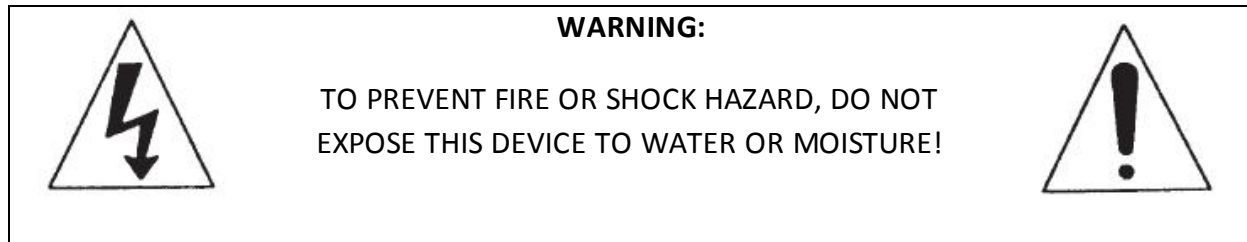

NOTE:

This equipment has been tested and found to comply with the limits for a Class B digital device, pursuant to Part 15 of the FCC Rules. These limits are designed to provide reasonable protection against harmful interference in a residential installation. This equipment generates, uses, and can radiate radio frequency energy and, if not installed and used in accordance with the instructions, may cause harmful interference to radio communications. However, there is no guarantee that interference will not occur in a particular installation. If this equipment does cause harmful interference to radio or television reception, which can be determined by turning the equipment off and on, the user is encouraged to try to correct the interference by one or more of the following measures:

- Reorient or relocate the receiving antenna.
- Increase the separation between the equipment and receiver.
- Connect the unit into an electrical outlet on a circuit different from that to which the receiver is connected.
- Consult the dealer or an experienced radio/TV technician for help.

IMPORTANT SAFETY INSTRUCTIONS

Read Instructions – All the safety and operating instructions should be read before the product is operated.

Retain Instructions – The safety and operating instructions should be retained for future reference.

Heed Warnings – All warnings on the product and in the operating instructions should be adhered to.

Follow Instructions – All operating and use instructions should be followed.

Cleaning – The product should be cleaned only with a polishing cloth or a soft dry cloth. Never clean with furniture wax, benzene, insecticides or other volatile liquids since they may corrode the cabinet.

Attachments – Do not use attachments not recommended by the product manufacturer as they may cause hazards.

Water and Moisture – Do not use this product near water — for example, near a bathtub, wash bowl, kitchen sink, or laundry tub; in a wet basement; or near a swimming pool; and the like.

Accessories – Do not place this product on an unstable cart, stand, tripod, bracket, or table. The product may fall, causing serious injury to a child or adult and serious damage to the product. Use only with a cart, stand, tripod, bracket, or table recommended by the manufacturer, or sold with the product. Any mounting of the product should follow the manufacturer's instructions, and should use a mounting accessory recommended by the manufacturer.

Cart – A product and cart combination should be moved with care. Quick stops, excessive force, and uneven surfaces may cause the product and cart combination to overturn.



Ventilation – Slots and openings in the cabinet are provided for ventilation and to ensure reliable operation of the product and to protect it from overheating, and these openings must not be blocked or covered. The openings should never be blocked by placing the product on a bed, sofa, rug, or other similar surface. This product should not be placed in a built-in installation such as a bookcase or rack unless proper ventilation is provided or the manufacturer's instructions have been adhered to.

Power Sources – This product should be operated only from the type of power source indicated on the marking label. If you are not sure of the type of power supply to your home, consult your product dealer or local power company.

Location – The appliance should be installed in a stable location.

Nonuse Periods – The power cord of the appliance should be unplugged from the outlet when left un- used for a long period of time.

Grounding or Polarization

- If this product is equipped with a polarized alternating current line plug (a plug having one blade wider than the other), it will fit into the outlet only one way. This is a safety feature. If you are unable to insert the plug fully into the outlet, try reversing the plug. If the plug should still fail to fit, contact your electrician to replace your obsolete outlet. Do not defeat the safety purpose of the polarized plug.
- If this product is equipped with a three-wire grounding type plug, a plug having a third (grounding) pin, it will only fit into a grounding type power outlet. This is a safety feature. If you are unable to insert the plug into the outlet, contact your electrician to replace your obsolete outlet. Do not defeat the safety purpose of the grounding type plug.

Outdoor Antenna Grounding – If an outside antenna or cable system is connected to the product, be sure the antenna or cable system is grounded so as to provide some protection against voltage surges and built-up static charges.

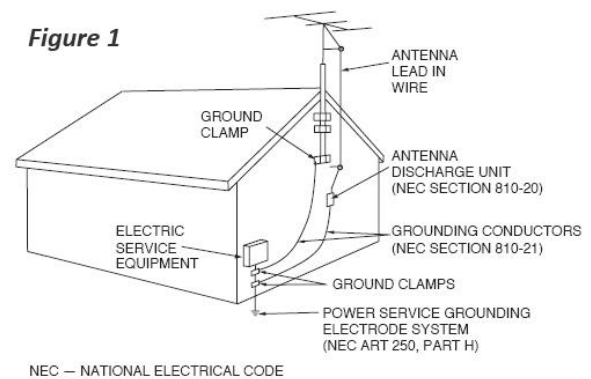

Article 810 of the National Electrical Code, ANSI/NFPA 70, provides information with regard to proper grounding of the mast and supporting structure, grounding of the lead-in wire to an antenna discharge unit, size of grounding conductors, location of antenna-discharge unit, connection to grounding electrodes, and requirements for the grounding electrode.

See **Figure 1**.

Power Cord Protection – Power-supply cords should be routed so that they are not likely to be walked on or pinched by items placed upon or against them, paying particular attention to cords at plugs, convenience receptacles, and the point where they exit from the product.

Lightning – For added protection for this product during a lightning storm, or when it is left unattended and unused for long periods of time, unplug it from the wall outlet and disconnect the antenna or cable system. This will prevent damage to the product due to lightning and power-line surges.

Power Lines – An outside antenna system should not be located in the vicinity of overhead power lines or other electric light or power circuits, or where it can fall into such power lines or circuits. When installing an outside antenna system, extreme care should be taken to keep from touching such power lines or circuits as contact with them might be fatal.

Overloading – Do not overload wall outlets, extension cords, or integral convenience receptacles as this can result in a risk of fire or electric shock.

Object and Liquid Entry – Never push objects of any kind into this product through openings as they may touch dangerous voltage points or short-out parts that could result in a fire or electric shock. Never spill liquid of any kind on the product.

Servicing – Do not attempt to service this product yourself as opening or removing covers may expose you to dangerous voltage or other hazards. Refer all servicing to qualified service personnel.

Damage Requiring Service – Unplug this product from the wall outlet and refer servicing to qualified service personnel under the following conditions:

- When the power supply cord or plug is damaged.
- If liquid has been spilled, or objects have fallen into the product.
- If the product has been exposed to rain or water.
- If the product does not operate normally by following the operating instructions. Adjust only those controls that are covered by the operating instructions as an improper adjustment of other controls may result in damage and will often require extensive work by a qualified technician to restore the product to its normal operation.
- If the product has been dropped or damaged in any way.
- When the product exhibits a distinct change in performance - this indicates a need for service.

Replacement Parts – When replacement parts are required, be sure the service technician has used replacement parts specified by the manufacturer or have the same characteristics as the original part. Unauthorized substitutions may result in fire, electric shock, or other hazards.

Safety Check – Upon completion of any service or repairs to this product, ask the service technician to perform safety checks to determine that the product is in proper operating condition.

Wall or Ceiling Mounting – The product should not be mounted to a wall or ceiling.

Heat – The product should be situated away from heat sources such as radiators, heat registers, stoves, or other products (including amplifiers) that produce heat.

PRODUCT INFORMATION

GENERAL INFORMATION

- The device should be situated away from heat sources such as radiators, heat registers, stoves, or other appliances (including amplifiers) that produce heat.
- Do not let insecticides, benzene, or thinner come in contact with the surface of the unit.
- Never disassemble or modify your unit in any way, doing so will void your manufacturer's warranty.
- Never plug this unit in to a dimmer pack.
- Do not attempt to operate this unit if it becomes damaged in any way.
- This unit is intended for indoor use only, use of this product outdoors voids all warranties.
- Always mount this unit in a safe and stable manner.
- Disconnect from main power before making any type of connection.

This unit has been thoroughly tested and has been shipped in perfect operating condition. Carefully check the shipping carton for damage that may have occurred during shipping. If the carton appears to be damaged, carefully inspect your unit for any damage. Be sure all accessories needed to operate the unit have arrived intact. In the event damage has been found or parts are missing, please contact our toll free customer support number for further instructions. Please do not return the unit to your dealer without first contacting customer support.

CLEANING INFORMATION

The CD player should be cleaned only as recommended by the manufacturer. Use a soft cloth to wipe down the outside of the unit. For stubborn stains moisten a soft cloth with glass cleaner or other mild detergent to wipe away any stains. Use a soft cloth to wipe any residual cleaner. Never use volatile cleaners such as benzene, solvent, or thinner to clean your unit, these cleaners will damage the unit's surface.

The pick-up lens should not become dirty under normal usage. If the lens does become dirty, contact American Audio Technical Support for further instructions. Third party lens cleaners are available but not highly recommended. Use of some of these cleaners may damage the pick-up lens, be sure to follow extreme caution when using these types of cleaners.

CUSTOMER SUPPORT

American Audio® provides a toll free customer support line, to provide set up help and to answer any question should you encounter problems during your set up or initial operation.

You may also visit us on the web at www.americanaudio.eu for any comments or suggestions.

For service related issue please contact American Audio®.

Service Hours are Monday through Friday 9:00 a.m. to 5:00 p.m. Pacific Standard Time.

Voice: (800) 322-6337

Fax: (323) 582-2941

E-mail: support@americanaudio.eu

Warning! To prevent or reduce the risk of electrical shock or fire, do not expose this unit to rain or moisture.

Caution! There are no user serviceable parts inside this unit. Do not attempt any repairs yourself; doing so will void your manufactures warranty. In the unlikely event your unit may require service please contact customer support. Please do not return to your dealer without first contacting customer support.

SET-UP

CHECKING THE CONTENTS

Be sure your UCD-200 package was shipped with the following:

- UCD-200 Dual CD/USB player unit
- User Manual (this booklet)
- UCD-200 Controller Head Unit
- Dual Male to Male RCA cable

INSTALLING THE UNITS

- Place your unit on a flat surface or mount it in a secure rack mount case.
- Be sure the player is mounted in a well-ventilated area where it will not be exposed to direct sunlight, high temperatures, or high humidity.
- Try to place the unit as far as possible from TVs and tuners, as the unit may cause undesirable interference.

CONNECTIONS

- Be sure main power is connected last to prevent any electrical damage.
- **AUDIO CONNECTIONS:** Use the included RCA cable to connect the UCD-200 outputs to the line inputs of a mixer. Never connect a CD player's output to a mixer's "phono" inputs.

CAUTION: Be sure to use the supplied control cables. Using a different type of cable may result in unit damage. To avoid severe unit damage, be sure main power is off when connecting the control cables.

CAUTION

To avoid severe damage to the unit, be sure the power is off when making connections to the unit.

CAUTION

The player will work normally when the main unit is mounted with the front panel within 15 degrees of the vertical plane. If the unit is tilted excessively, disks may not be loaded or unloaded properly.

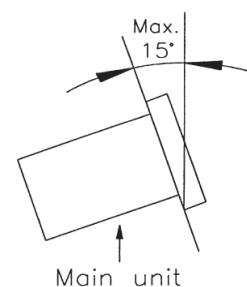

MAIN FEATURES

- 8 times over sampling 1 bit D/A converter
- Auto Cue
- 60 Second Transport Protection (*)
- Pitch Control and Bend (+/-4%, +/-8%, +/-16%, or +/-100% [+/-100 CD Only])
- Jog Wheel Pitch Bend (**)
- Single or Continuous Play
- Selectable Time Display
- Flip Flop™ (Relay Playback) (***)
- Dual USB Slots for MP3 Playback
- Pitch Display
- Reads CD and CD-R Media
- Repeat in Single Mode
- 4 Speed Search
- Database Builder

(*) 60 Second Transport Protection: The CD transport tray will automatically close if left open for more than 60 seconds. If a CD is left in the tray it will immediately cue.

(**) Jog Wheel Pitch Bend: During normal playback, the jog wheel acts as a momentary pitch bend. Turning the wheel in a clockwise direction will increase the speed and turning the wheel in a counter-clockwise direction will decrease the speed.

(***) Flip-Flop™: For FLIP-FLOP™ results you must use both drives. Connect your UCD-200 as described in the set-up section of this manual. This feature will start the next player side once one player side has ended. For example, if drive one is playing and it ends, drive two will instantly begin to play. You may set FLIP-FLOP™ to play track to track or music source device to music source device.

SD CARD INFORMATION

- Make sure your SD Card only has MP3 files on it.
- Do not have any other file type on your SD Card; no photo files, etc...
- American Audio SD Players can read SD HC (High Capacity) Cards up to 32GB

Note: For higher quality MP3 files (more than 128 kbps) American Audio recommends “High Speed” SD Cards. Using high speed cards will ensure the best performance with your American Audio SD Player.

USB INFORMATION

- Make sure your USB device has only MP3 files on it. There cannot be any other type of files on your device, NO photo files, etc...
- If you are using a SD Card via SD Card reader, you must remove the SD Card reader first to change SD Card's. Please do not remove the SD Card from the SD Card reader while the card reader is still connected to the unit.
- Only supports FAT/FAT32 formatted devices.

FUNCTIONS AND CONTROLS

REMOTE CONTROL – FRONT CONTROLS

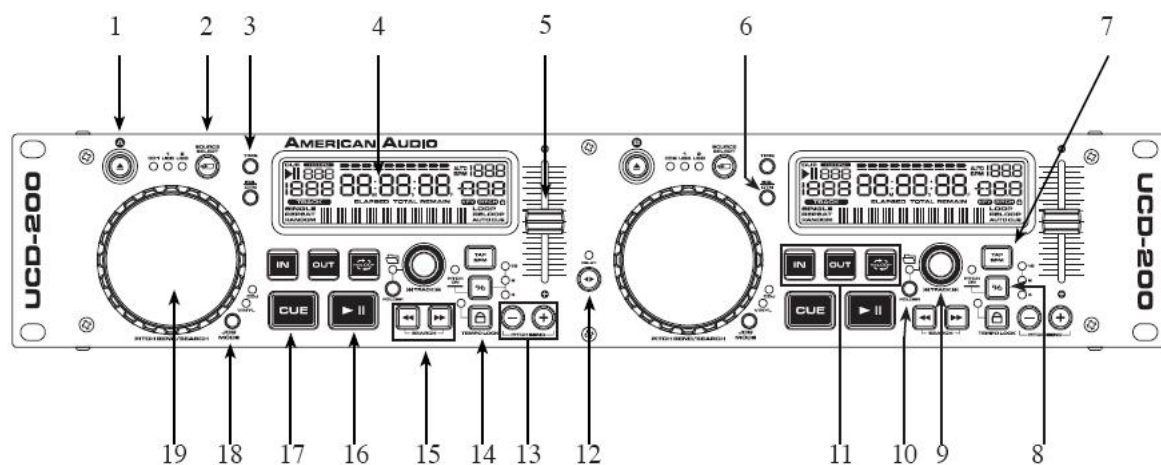

Figure 3

(1) OPEN/CLOSE (Disc Tray Open/Close) – This button is used to open and close the disc transport tray door. **NOTE:** When a disc is loaded, the tray will not open unless the unit is in pause or cue mode.

(2) SOURCE SELECTOR – Press this button to select your desired playback source. Select CD player, USB 1, or USB 2. The source indicator LED will light when the selected source is activated.

(3) TIME – The TIME button is used to change the displayed time values. Time can be displayed as *Elapsed Track Time*, *Remaining Track Time*, and *Total Disc Remaining Time*. *Total Disc Remaining Time* can only be displayed for standard CDs.

(4) LIQUID CRYSTAL DISPLAY (LCD) – This high quality LCD indicates all the functions (play, pause, cue, etc.), as they occur. This display is viewable at several comfortable angles as described later. The LCD icons will be described in the next section.

(5) PITCH SLIDER – This slider is used to adjust the playback pitch percentage when the Pitch **(8)** function is activated. The slider is a set adjustment and will remain set until the pitch slider is moved or the Pitch **(8)** function has been turned off. The maximum pitch range of the slider is +/-100%. This adjustment can be made with or without a music source. The pitch adjustment will remain even if a music source has been removed, and will reflect on any other music source that is loaded into the unit. That is to say, if you set a +2% pitch on one music source, remove it and insert another, that music source will also have a +2% pitch. The amount of pitch being applied will be displayed in the LCD **(4)**. Use this slider to match the BPM's of this unit to that of another music source. By changing the pitch of one music source with respect to the other in this way, the beats can be matched.

(6) SGL/CTN – This button allows the unit's play mode to change between *Single* and *Continuous* mode. In single mode the unit will play a single track and return to cue mode. In continuous mode the unit continues to play track by track.

(7) TAP/BPM BUTTON – Press this button to switch between manual BPM and Auto BPM. When in manual BPM mode, tap this button to the beat of the current track.

(8) PITCH BUTTON / PITCH PERCENTAGE SELECTOR – This button is used to turn the pitch function on and off and choose the pitch percentage. The pitch percentages to choose from are 4%, 8%, 16%, and 100%. To activate the pitch slider, press the button for at least 3 seconds. The pitch functions of the Pitch Slider **(5)** will not function without this function being activated. The pitch slider and "+" and "-" pitch bend buttons have a maximum range of +/-100%. (100% Pitch Bend/Pitch Slider works with CD only)

(9) TRACK/FOLDER SEARCH KNOB – This knob is used to search/scroll through the tracks or folders on an active audio source. The search feature depends on the setting of the *Folder* button. If you press the knob in and turn it while in track mode, you can skip ahead 10 tracks. **Example:** *if you are at Track #1, pressing the knob and turning it clockwise will skip you to Track #11. If you press the knob and turn it clockwise again, it will skip to Track #21. If there are not that many tracks, it will go back to Track #1.*

(10) FOLDER/TRACK BUTTON – This button is used to toggle between folders and tracks. When the LED of the *Folder* button is lit, the player is in Folder Search mode. Hold the *Folder* button down for at least 2 seconds to activate and deactivate the repeat function.

- **REPEAT ON:** All the track in the current folder will play track by track until the *Repeat* function is deactivated.
- **REPEAT OFF:** All the tracks in the device will play in the normal mode.
- **SINGLE REPEAT:** The current playing track will play continuously.

(11) IN, OUT, & RELOOP



- **IN BUTTON** – “CUE ON THE FLY” - This function allows you to set a Cue Point without music interruption (“on the fly”). This button also sets the starting point of a loop.
- **OUT BUTTON** – This button is used to set the ending point of a loop. A loop is started by pressing the *IN* button, pressing the *OUT* button sets the loop ending point. The loop will continue to play until the *OUT* button is pressed once again.
- **RELOOP BUTTON** – If a loop has been made, but the player is not actively in loop mode (a loop is not playing), pressing the *Reloop* button will instantly reactivate the loop mode. To exit the loop, press the *Loop Out* button.

(12) RELAY BUTTON – This button activates Flip-Flop™ mode.

(13) PITCH BEND BUTTONS

- **(-) PITCH BEND** – The (-) pitch bend function creates a momentary “Slow Down” in the pitch speed (Beats per minute - BPM) when the Pitch **(8)** function is activated. This function allows the beats between two CD’s or any other music source to match. This is a momentary function. When the button is depressed the pitch speed will automatically return to the Pitch Slider's **(5)** selected pitch. Holding down this button will give a maximum of -100% pitch. Be sure to remember that this function is a momentary pitch adjustment, for a more precise adjustment use the Pitch Slider **(5)** to match the BPM’s with another playing music source.
- **(+) PITCH BEND** – The (+) pitch bend function creates a momentary “BUMP” in the pitch speed (Beats per minute - BPM) when the Pitch **(8)** function is activated. This function allows the beats between two CD’s or any other music source to match. This is a momentary function. When the button is depressed the pitch speed will automatically return to the Pitch Slider's **(5)** selected pitch. Holding down this button will give a maximum of +100% pitch. Be sure to remember that this function is a momentary pitch adjustment, for a more precise adjustment use the Pitch slider **(5)** to match the BPM’s with another playing music source.
- **(14) TEMPO LOCK FUNCTION** – This button activates the Tempo Lock function. This function allows you to use the Pitch Slider to speed up or slow down playback speed without altering the tonal pitch of the track. When this function is not engaged the original tonal pitch of the track will be altered giving you the "chipmunk" effect when a track is played at a high rate of speed or the "James Earl Jones" effect when a track is slowed too much.

(15) SEARCH BUTTONS

-  This search button allows you to quickly scan backwards through a track.
-  This search button allows you to quickly scan forwards through a track.

(16) PLAY/PAUSE BUTTON – Each press of the Play/Pause button causes the operation to change from play to pause or from pause to play. While in play mode, the green play LED will glow, and while in pause mode, the green play LED will flash.

(17) CUE – Pressing the CUE button during playback immediately pauses playback and returns the track to the last set cue point. The red Cue Button LED will glow when the unit is in cue mode. The LED will also flash every time a new Cue Point is set. The CUE button can also be held down to momentarily play music. When you release the CUE button it instantly returns to the last set Cue Point.

(18) JOG WHEEL MODE BUTTON

- **VINYL MODE** – In this mode the scratch effect is active. Use the jog wheel to simulate the scratch effect.
- **CDJ MODE** – In this mode the scratch effect is deactivated the jog wheel can be used to pitch bend during playback and frame search in pause mode.

(19) JOG WHEEL – The jog wheel serves three functions depending on the current operating mode:

1. The jog wheel will act as a slow frame search control when the unit is in pause or cue mode allowing you to set a specific cue point or find a particular starting point.
2. The jog wheel also works as a momentary pitch bend during playback. Turning the wheel clockwise will increase the pitch percentage up to 100%, and turning the wheel in the counter-clockwise direction will decrease the pitch percentage up to -100%. The pitch bend will be determined on how fast you turn the wheel.
3. The jog wheel is also used to simulate the scratch effect.

REMOTE CONTROL – REAR CONTROLS

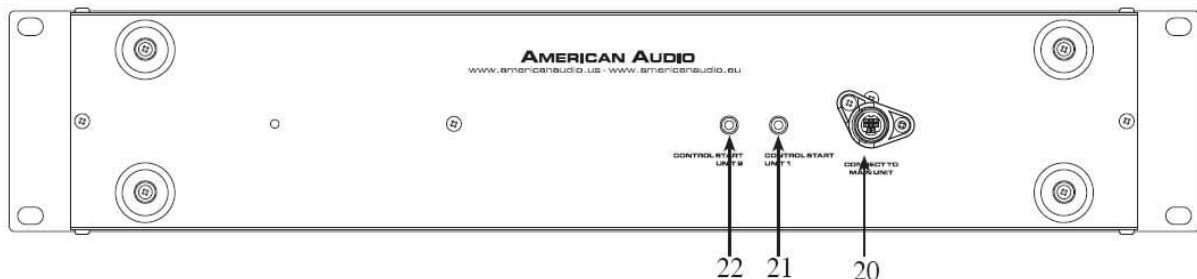

Figure 4

(20) REMOTE JACK – Connect the supplied 8 pin din cable from this jack to the player's remote connector. This will allow you to control the player functions.

(21) UNIT 1 CONTROL START JACK – Connect the supplied mini-plug from the control start jack on the rear of the unit to the control out jack of a compatible mixer. This will enable the "Q-Start" function.

(22) UNIT 2 CONTROL START JACK – Connect the supplied mini-plug from the control start jack on the rear of the unit to the control out jack of a compatible mixer. This will enable the "Q-Start" function.

PLAYER UNIT – FACE

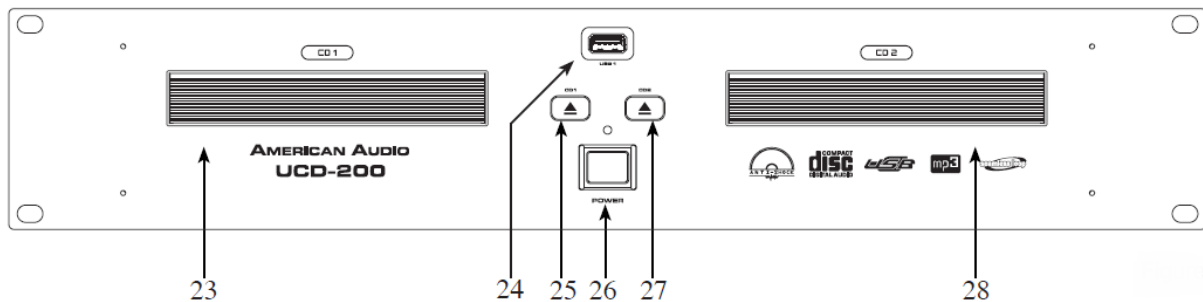

(23) DRIVE 1 Transport Tray - This tray is used to load and unload a compact disc into the drive 1 mechanism. The tray is opened and closed by pressing the Drive 1 OPEN/CLOSE button **(25)**. Never attempt to force the transport tray open or close when the power is turned off.

(24) USB PORT - This is the USB port where you can insert a USB stick, USB SD Card reader, or a compatible external hard drive for playback. **Very Important:** Please read earlier chapters for details regarding using USB devices.

(25) DRIVE 1 OPEN/CLOSE (Transport Tray Open/Close) - This button is used to open and close the Drive 1 transport tray. **NOTE:** When a disc is already loaded in the transport tray, the tray will not open unless the unit is in pause or cue mode.

(26) POWER SWITCH - This switch is used to control the unit's main power. A red LED directly above the power switch will glow to indicate main power is active.

(27) DRIVE 2 OPEN/CLOSE (Transport Tray Open/Close) - This button is used to open and close the Drive 2 transport tray. **NOTE:** When a disc is already loaded in the transport tray, the tray will not open unless the unit is in pause or cue mode.

(28) DRIVE 2 Transport Tray - This tray is used to load and unload a compact disc into the Drive 2 mechanism. The tray is opened and closed by pressing the Drive 2 OPEN/CLOSE button **(27)**. Never attempt to force the transport tray open or close when the power is turned off.

PLAYER UNIT – REAR

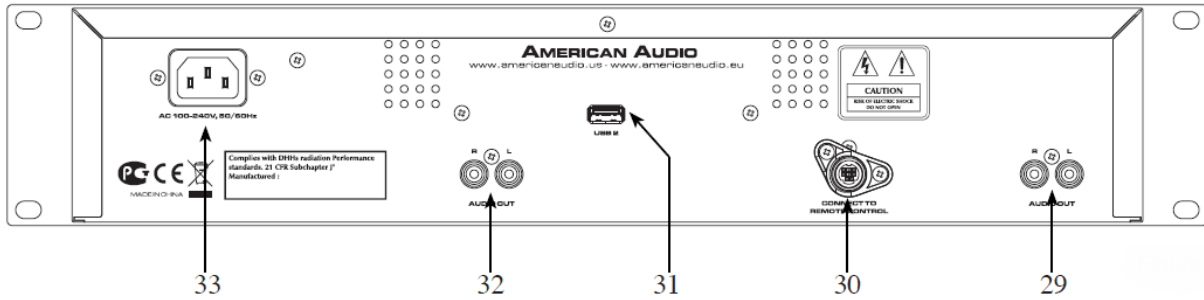

(29) DRIVE 1 AUDIO OUT R & L - These jacks send a left and right analog mono output signal. Use these jacks to send standard audio to a mixer or receiver. The red colored jack represents the right channel output and the white jack represents the left channel's output.

(30) REMOTE JACK - Connect the supplied 8 pin cable from this jack to the remote control's connector. This will allow you to control the player functions with the remote unit.

(31) USB PORT - This is the USB port where you can insert a USB stick, USB SD Card reader, or compatible external hard drive for playback

(32) DRIVE 2 AUDIO OUT R & L - These jacks send a left and right analog mono output signal. Use these jacks to send standard audio to a mixer or receiver. The red colored jack represents the right channel output and the white jack represents the left channels output.

(33) POWER CONNECTOR - This is the main power connection. Only use the supplied polarized power cord. Use of any other power may result in severe damage to the unit. Be sure the local power matches the unit's required power.

LIQUID CRYSTAL DISPLAY (LCD)

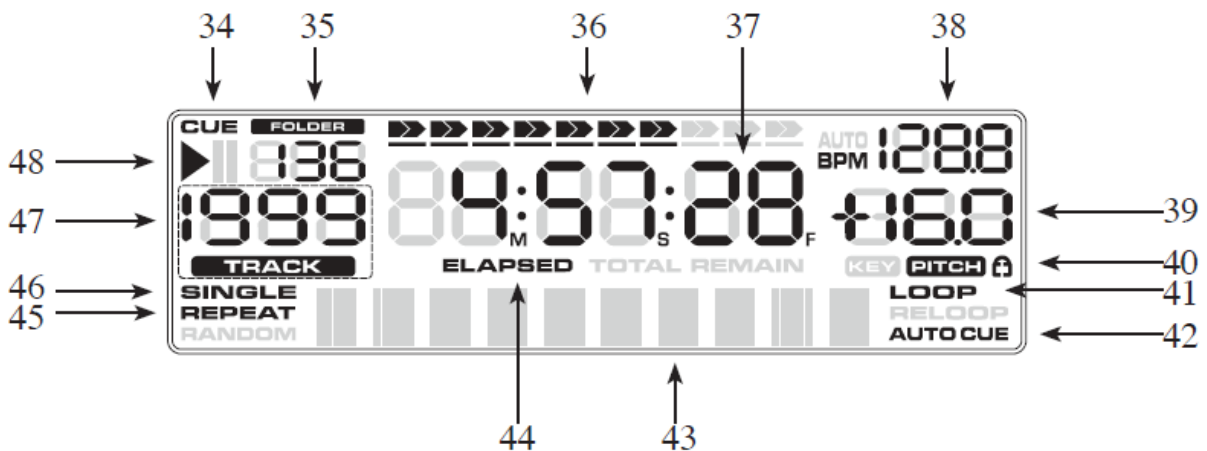

(34) CUE Indicator – This indicator will glow when the unit is in CUE mode and will flash every time a new CUE POINT is set.

(35) FOLDER Display – Indicates which folder you are in.

(36) Time Bar Indicator – This bar visually details the time defined in the Time Meter **(37)**. As with the Time Meter **(37)**, this bar is also dependent on the selected time function *Remain*, *Elapsed*, or *Total Remain*. The bar will begin to flash when 15 seconds of a track remain and will begin to rapidly flash when three seconds of a track remain. The flashing bar is a great visual reminder if a track is about to end. The flashing bar will function regardless of which time mode the unit is in.

(37) TIME METER – These indicators will detail the current minutes, seconds, and frames. The meter will display either the elapsed, total, or remaining time of a track or the entire disc. The display time will depend on the selected time function. The selected time function will be displayed above the Time Meter as *Total Remaining*, *Remaining Track Time* or *Elapsed Track Time*.

(38) BPM Meter – This meter will display the BPM's of the current track.

(39) Pitch Meter – This meter displays the pitch percentage being applied to playback by the Pitch Slider **(5)**. If the meter reads zero regardless of the Pitch Slider's **(5)** position, the Pitch **(8)** function is not activated.

(40) TEMPO LOCK –  This will indicate the Tempo Lock function is active.

(41) LOOP/RELOOP – The *Loop* indicator will appear when a loop is ready to be engaged. The *ReLoop* indicator will flash when a loop is engaged.

(42) AUTOCUE – This will indicate if the *Autocue* is on or off. Press and hold the SGL/CTN **(12)** button for 1 sec. to turn the *Autocue* function on and off. The unit's *Autocue* function will automatically set the cue point at the beginning of each track.

(43) CHARACTER DISPLAY – This will display the name of the track and/or folder when either a CD with text information or an MP3 disc with compatible ID3 tags is loaded into the unit.

(44) TOTAL/REMAIN/ELAPSED – When *Total Remain* is indicated in the LCD Display **(4)** the time meter will show the total disc remaining time. When *Remain* is indicated the time meter will show the current track's remaining time. When *Elapsed* is indicated the time meter will show the current track's elapsed time.

(45) REPEAT INDICATOR – This indicates the unit is in repeat play mode; the unit will continue to play all tracks in a selected folder until the mode is deactivated. To activate *Repeat* mode, press the Folder Button **(10)** for at least 2 seconds to activate and deactivate.

(46) SINGLE INDICATOR – This indicates the unit is in single play mode; the unit will play a single track and return to *Cue* mode. If the *Single* indicator is not displayed the unit is in continuous mode.

(47) TRACK INDICATOR – This double digit indicator details a current track. The number displayed in the track indicator is a direct reference to a track being selected for programming or a track in play, pause, or cue mode.

(38) PLAY INDICATOR – The *Play* indicator will glow when the unit is in play mode.

INTERNAL MENU

Use the internal menu as follows:

1. Hold the *Time* button for 3 seconds to enter the internal menu.
2. Turn the *Track Knob* to scroll through the different menus.
3. Press the *Track Knob* to enter the corresponding submenu.
4. Turn the *Track Knob* to change the submenus.
5. Press the *Time Button* to memorize your settings in any operating mode and exit the menu.

Playlist – Normal / Title / Artist / Album / Genre

Normally the unit will read your USB devices in order of folder names and file names in folders. Title, Artist, Album and Genre will use your last built database file when scrolling through the selected database in alphabetical order. When new files are added, it is necessary to build a new database for the MP3 files to read in any mode described.

Sensitivity – Touch Wheel Sensitivity Adjustment

Increase or decrease the sensitivity of the jog wheels touch sensor. The adjustment range is -20 ~ +20.

Sleep Time – No sleep, 5 ~ 120 min

Set the time the player takes to enter sleep mode. When in sleep mode, the player will either read *Sleep* or *ZZZZZ* on the LCD screen.

Line Setup – MODE= 1 ~ 3 (Line mode)

- Dis=0.5 ~ 12.0 sec. (LINE NAME start/stop time adjustment)
- Run=50 ~ 2000 msec. (LINE NAME move time adjustment)

Bit Rate – Display ON/OFF

Displays the bit rate of MP3 files.

Version – CON:XX (Control version)

Displays the firmware version.

- DSP:XX (DSP version)
- SER:XX (Servo version)

Load Default – Press Track Knob to enter Load Defaults. (LCD displays “Load OK”.)

Will reset all settings to factory default except for firmware version.

Exit & Save – Exit & Save Setting to Next Power On (LCD displays “Saving”.)

This will save all changes; if changes are not saved the unit will revert to last saved changes on power off.

Press the *Track Knob* to fast exit & save in any operating mode.

NOTE:

- **SLEEP TIME:** The CD player automatically shuts off the transport and laser after about 15 minutes when in pause or cue mode. This extends the life of your motor drive and laser. During sleep mode the display shows the word *Sleep*. To wake up the player, just press the Cue or Play button, the display turns to normal and is ready to receive instructions. You can enter the Sleep Time menu to adjust sleep time, range is 5 ~ 120 minutes.
- **SAVE:** PITCH ON/OFF, PITCH RANGE, SGL/CTN, AUTOCUE, TIME MODE, KEY LOCK, DISPLAY/SCROLL, TIME/JOG MODE.
- **DEFAULTS:** PITCH (ON), PITCH RANGE (8%), PLAY MODE (CTN), AUTO CUE (ON), TIME MODE (REMAIN), KEY LOCK (OFF), BITRATE (Disp. ON), REPEAT MODE (OFF), PLAYLIST (NORMAL), SLEEP (15 min), LINE SETUP (Model 1), DISPLAY (1 sec), RUNTIME (150msec).

BASIC OPERATION

OPENING AND CLOSING THE DISC TRAY

This is an electronic operation and can only work when the power is on. Press the Open/Close button (1) to open or close the disc tray. Pressing the Play/Pause button (16), will also automatically close the tray if it is open and immediately cue any CD that is in it. If the transport tray is left open for more than 60 seconds it will close automatically to prevent accidental damage to the transport. Again if a CD is left in the transport tray it will immediately cue to the first song. The disc tray cannot be opened during playback to prevent playback from being interrupted if the Open/Close button (1) is pressed accidentally. Stop playback, then press the Open/Close button (1).

LOADING DISCS

The UCD-200 can play both 3 inch (8 cm) and 5 inch (12 cm) compact discs (CDs). Odd shaped and oval CD's are not compatible. When loading a CD into the unit, always hold the disc by its edges and place it in the disc tray. Never touch the signal surface (the glossy side).

When using 5 inch/12 cm discs, place the disc in the outer tray guides (Figure 8), and when using 3 inch/8 cm discs, place them securely in the inner guides (Figure 9).

Caution:

- Never insert any foreign objects in the disc tray.
- Never attempt to insert more than one disc in the disc tray at a time. Doing so may result in severe damage to the unit.
- Never force the transport tray open or closed when the power is off, as this may result in malfunction and damage the transport system.

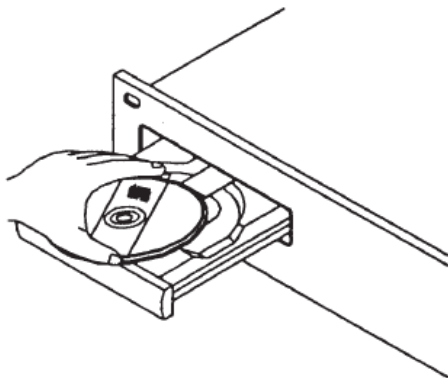

Figure 8 (5 inch / 12 cm disk)

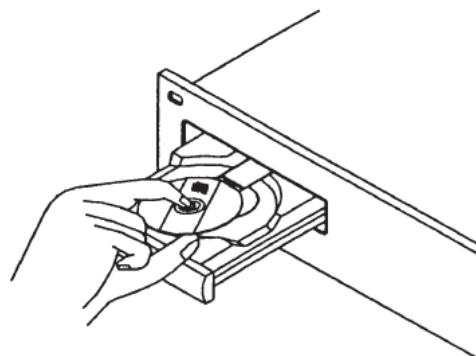

Figure 9 (3 inch / 8 cm disk)

LOADING USB DEVICE

The UCD-100 can only read SDHC (High Capacity) Cards up to 32GB. The file format is MP3 only. When connecting a USB stick, USB card reader, or external hard drive, make sure you are correctly lined up with the USB port and gently insert the USB connection. To disconnect a USB drive, stop playback and “pull out” the USB connection.

CAUTION: *Never remove a USB device while in PLAY mode.*

SELECTING YOUR AUDIO SOURCE

Select your desired audio source using the Source Selector button **(2)**. This button lets you toggle between the CD player, USB port 1 and USB port 2. The LED's will verify which source is active.

The different sources can only be selected while in Pause mode.

SELECTING TRACKS

Select a desired track by using the Track knob **(9)**. Rotate the Folder/Track button **(9)** clockwise to select the next track, or rotate the knob counter-clockwise to select the previous track. You may turn and hold the Track knob **(9)** to change tracks continuously at a higher speed.

When you are using the knob to select a new track during playback (a track already playing) the new track you selected will immediately begin playback as soon as the search operation is completed.

STARTING PLAYBACK

Pressing the Play/Pause button **(16)** with a music source device activated will immediately start playback. The point at which playback starts (cue point) will automatically be stored in the memory as cue point. The unit will return to this cue point (the point at which playback started) when the Cue button **(17)** is pressed.

Pausing temporarily stops playback. Pressing the Play/Pause button **(16)** changes the operating mode between play and pause.

STOPPING PLAYBACK

Stopping playback will not stop the drive mechanism, but merely pause or cue the track. There are two ways to stop playback:

1. Press the Play/Pause button **(16)** during playback to pause at that point.
2. Press the Cue button **(17)** during playback to return the track to its last cue point.

SETTING CUE POINTS

“Cueing” is the action of preparing for playback. The unit is designed to automatically cue at the first audible signal on the first track of a disc when a disc is inserted. If a track is selected before a disc is inserted, the unit will automatically cue to the first audible signal for the selected track.

You may press the IN button **(11)** on the fly (while the disc is playing). This will set a Cue Point without music interruption.

Pressing the Cue button **(17)** will now return you to this exact point.

CHANGING THE TIME DISPLAY **(37)** / TIMEBAR **(36)**

The time may be displayed in three different modes; *Total Remain*, *Remain*, and *Elapsed*. During normal playback, pressing the Time button **(3)** will change the time display information **(17)** in the LCD **(4)**. The following is a breakdown of the time settings and their definitions:

- **Total Remain** - details the time in the LCD as the current CDs' total remaining time.
- **Remain** - details the time in the LCD as the current tracks' remaining running time.
- **Elapsed** - details the time in the LCD as the current tracks' elapsed running time.

TIME BAR INDICATOR

The time bar in the LCD **(4)** visually details the time defined in the Time Meter **(37)**. This bar is also dependent on the selected time function; *Remain*, *Elapsed* or *Total Remain*. This bar will begin to flash when 15 seconds of a track remain and will begin to rapidly flash when three seconds of a track remain. The flashing bar is a great visual reminder a track is about to end. The flashing bar will function regardless of which time mode the unit is in.

PITCH ADJUSTMENTS

This function will increase or decrease a track's playback speed or "pitch", this is not a momentary change as in "Pitch Bending". The maximum pitch percentage of the Pitch Slider is +/-100%. The Pitch Slider (5) is used to decrease or increase the playback pitch. If the slider is moved up (towards the top of the unit), the pitch will decrease, if the slider is moved down (towards the bottom of the unit) the pitch will increase.

USING THE PITCH SLIDER PERCENTAGE SELECTOR (8)

You may choose a pitch operating range at any time. To change the operating range be sure the pitch function is turned on, see *Figure 10*.

The pitch percentage can be changed between +/-4%, +/-8%, +/-16%, and 100%. 4% will allow the least amount of pitch manipulation and 100% will allow the most amount of pitch manipulation.

To adjust the different values, press the Pitch ON/Off Button (8) and tap on the % button (8) until your desired value is reached.

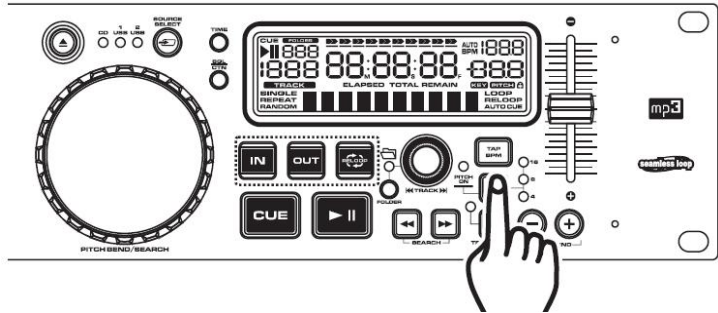

Figure 10

The LED of the % button (8) is glowing red for 4%, glowing yellow for 8%, or glowing amber for 16%, and all LEDs glowing for 100%.

ACTIVATING THE PITCH SLIDER (5)

To activate the Pitch Slider (5), you must turn the pitch function on.

Press the Pitch button (8) to turn on the pitch function, when the pitch function is activated LED will begin to glow.

If the pitch function is not activated the Pitch Slider (5) will not function.

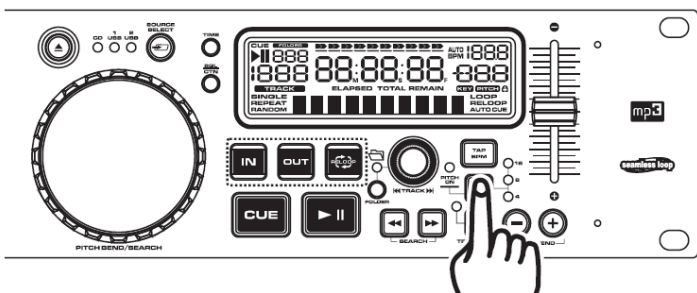

Figure 11

USING THE PITCH SLIDER (5)

To use the Pitch Slider (5), move the slider up and down.

Down will increase the pitch and up will decrease the pitch.

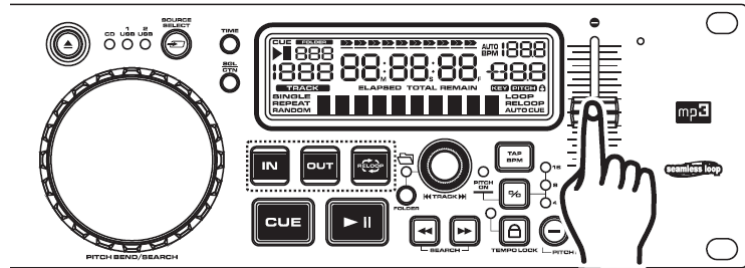

Figure 12

PITCH BEND

This function will momentarily increase or decrease a tracks playback speed. There are two ways to operate this function with the (-) & (+) Pitch Buttons (13) or with the Jog Wheel (19). The maximum pitch bend percentage allowed is +/-16%. The pitch bend function will work in conjunction with the Pitch Slider (5) pitch setting.

Pitch Bend Buttons (14)

The (+) Pitch Bend button (13) will provide a speed bump and the (-) Pitch Bend button (13) will provide a slowdown. The maximum range of the Pitch Bend buttons is 100%. The extent to which the speed changes are proportionate to the amount of time the button is pressed. For example, if the (+) Pitch Bend button (13) is held down continuously, the disc speed will increase and will continue to increase until it reaches a maximum of 100% speed gain. When you release the (+) Pitch Bend button (13) the disc speed will automatically return to its previous speed.

(+) PITCH BEND BUTTON (13)

Holding down or tapping on the (+) Pitch Bend button (13) will provide a speed bump in the playback pitch.

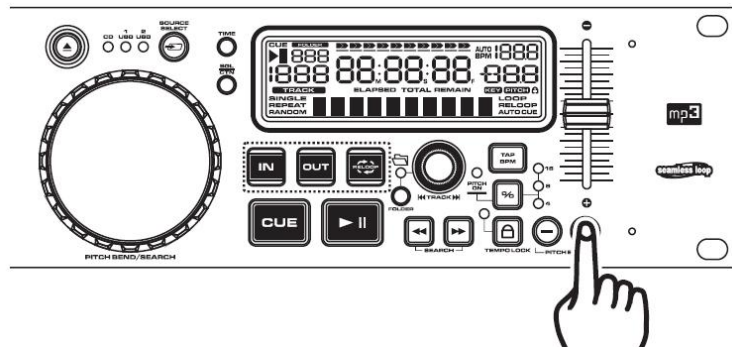

Figure 13

(-) PITCH BEND BUTTON (13)

Holding down or tapping on the (-) Pitch Bend button (13) will provide a slowdown in the playback pitch.

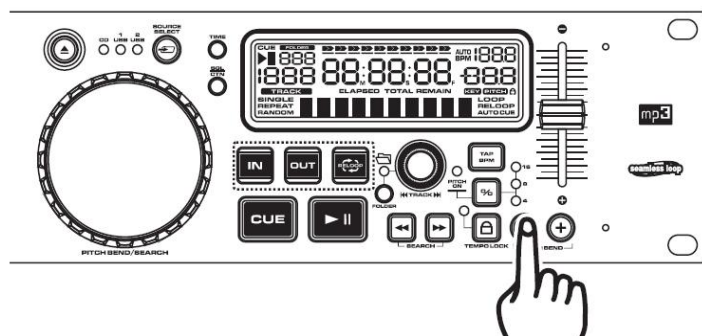

Figure 14

JOG WHEEL (19)

The Jog Wheel (19) will temporarily bend the pitch if a track is in play mode.

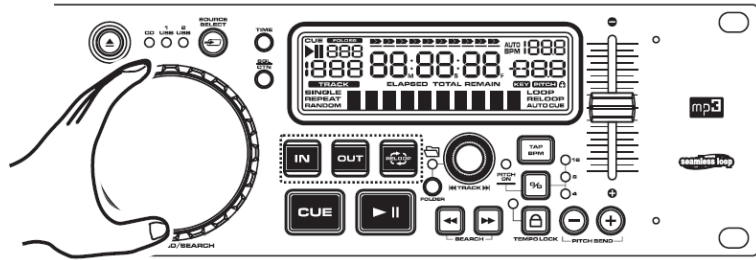

Figure 15

Turning the wheel in a clockwise direction will increase your track pitch and turning the wheel in a counter-clockwise direction will slow your track pitch.

The speed you rotate the Jog Wheel (19) will determine pitch bend percentage, to a maximum of +/-100%.

CREATING AND PLAYING A LOOP

A loop is a sound loop that plays continuously. You can use this loop to create a dramatic effect in your mixing. This loop has no time limit and you could actually loop the entire length of disc.

Press Play/Pause button (16) to activate playback mode.

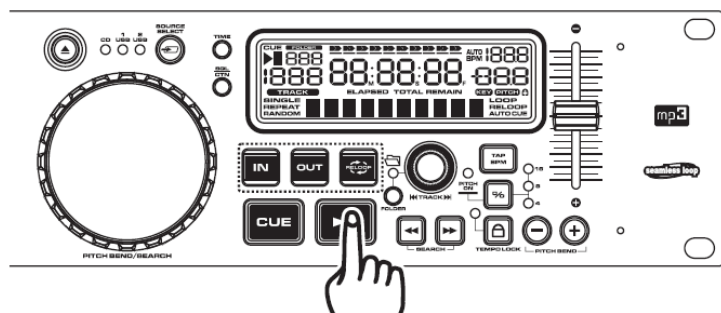

Figure 16

Press the IN button (11). This will set the starting point of the Seamless Loop (Figure 17).

The IN button (17) will blink.

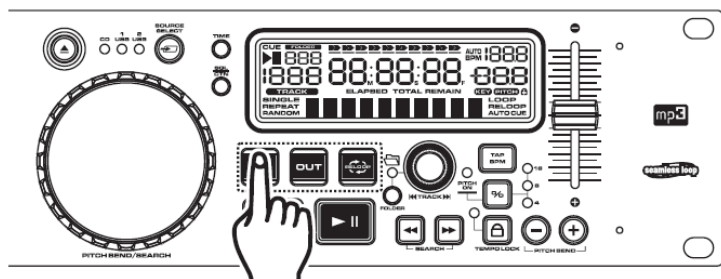

Figure 17

Press the OUT button **(11)** to set the ending point for your LOOP **(Figure 18)**. The IN and OUT buttons will stay lit indicating a LOOP is playing. Press the OUT button again to cancel the Loop.

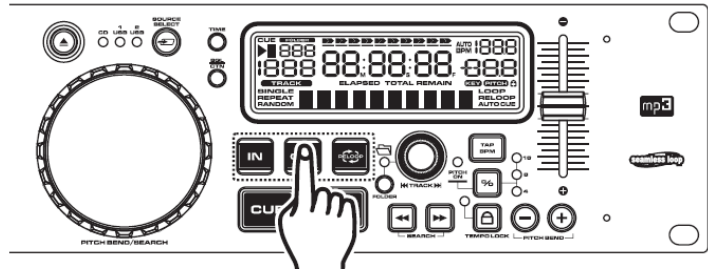

Figure 18

Press the Reloop button **(11)** to reactivate the loop. Press the OUT button **(11)** to deactivate the loop.

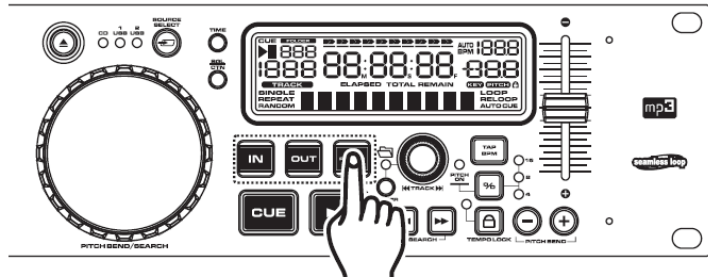

Figure 19

Press the OUT button **(11)** again when you reach your new ending point **(Figure 18)**.

- **For a shorter Loop:** Press the OUT button **(11)** at sooner point in the track **(Figure 18)**.
- **For a longer Loop:** Press the OUT button **(11)** at later point in the track **(Figure 18)**.

LOOP EDITING

The UCD-200 allows you to edit loops on the fly by pressing the IN and OUT buttons. By pressing the IN button at your desired point you can move your loop "in" point forward. Pressing the OUT button will exit the loop.

You can also edit the loop by pressing the Reloop button. Press this button for about 2 seconds, the LCD screen will display the time of your "out" point. You can now use the Jog Wheel to fine tune your loop and "out" point. Turning the Jog Wheel clockwise will move your "out" point forward, lengthening your loop. Turning the Jog Wheel counter-clockwise will move your "out" point backwards, shorting your loop.

RELAY (FLIP-FLOP™)

This feature is a kind of “auto pilot”. Flip-Flop™ mode can only function with the both drives of the UCD-200. With Flip-Flop™ you can have one drive begin playback when the other ends. You can Flip Flop™ single tracks, or an entire music source device.

- Load disc drives with audio discs or connect USB.
- Press the Relay button (12), the LED above the Relay button will light up letting you know that Flip-Flop™ mode has been activated. Press the SGL/CTN button (6) to choose between Single mode or Continuous mode.
- After they have both cued, press the Play/Pause button(16) on one of your drives to begin playback.
- If you have the player set to *Single* mode, the first single track will play and after it has ended the second track will immediately begin playback. If the player is set to *Continuous* mode, the first music source will play all the way through, and then after it has ended the second music source will start.
- FLIP FLOP™ will continue until you stop it or power is interrupted.
- To deactivate Flip-Flop™ mode, press the Relay button again.

DATABASE BUILDER (PC ONLY)

MINIMUM HARDWARE REQUIREMENTS

- **CPU:** Intel Pentium 4, 1GHz processor or above, Intel Centrino Mobile Technology 1.6 GHz
- **RAM:** 512MB RAM
- **DISC SPACE:** 100MB of free disc space needed
- **OS:** Microsoft Windows XP SP3, Vista SP2

Note: The device includes a database management software that enables you to search for your files by Title, Artist, Album, and Genre.

INSTALLATION

Refer to the following figures for installing the database management software on your computer.

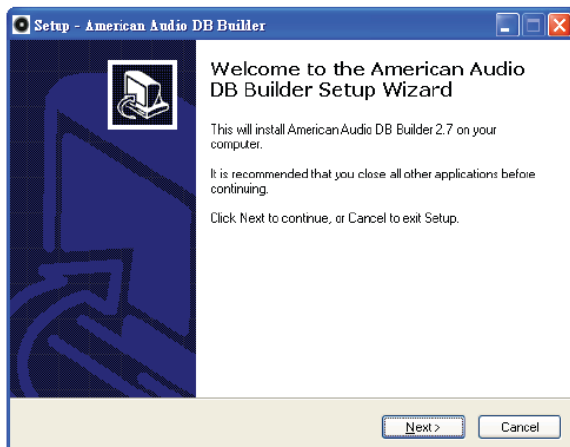

Step 1: Click Next >

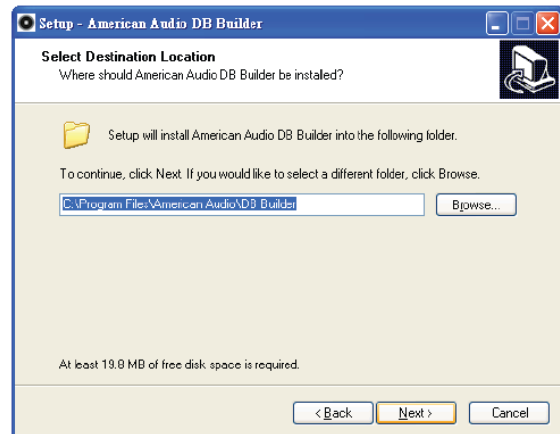

Step 2: Click Next >

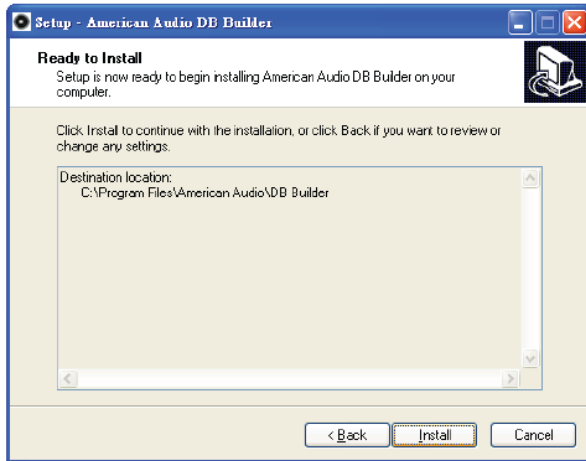

Step 3: Click *Install*

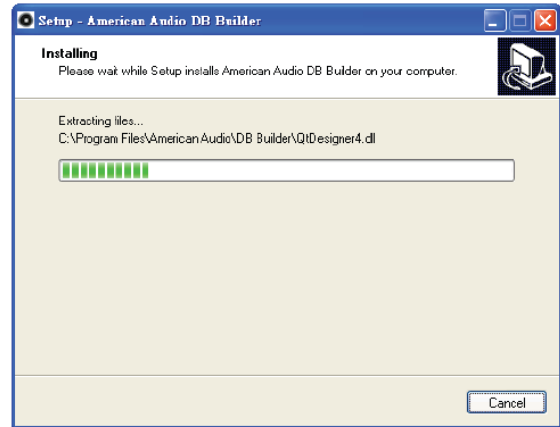

Step 4: Processing

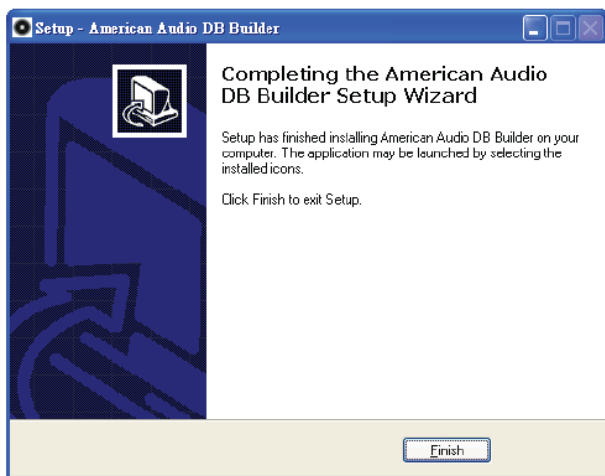

Step 5: Click *Finish*

The database builder will scan your USB hard drive and create database files so that you may locate the files in your music library to your liking.

OPEN DATABASE BUILDER

To open the database builder, click **Start Menu > Programs > American Audio > Database Builder**.

To build a database your hard drive must be FAT formatted.

Build Database file on memory device.

Format the selected source.

Note: Make sure that all files are backed up prior to formatting your device.

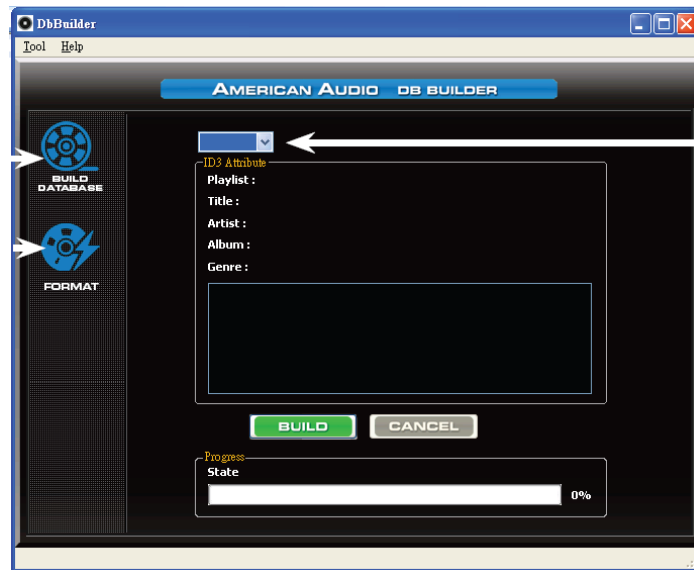

Drive Selector: Select your desired drive to format or build a database file.

HOW TO FORMAT YOUR MEMORY DEVICE

1. Select your desired device in the drop down menu.
2. Click *Format*, on the modes in the left column.
3. Click *Format*. For best results set the cluster size to *Auto*.

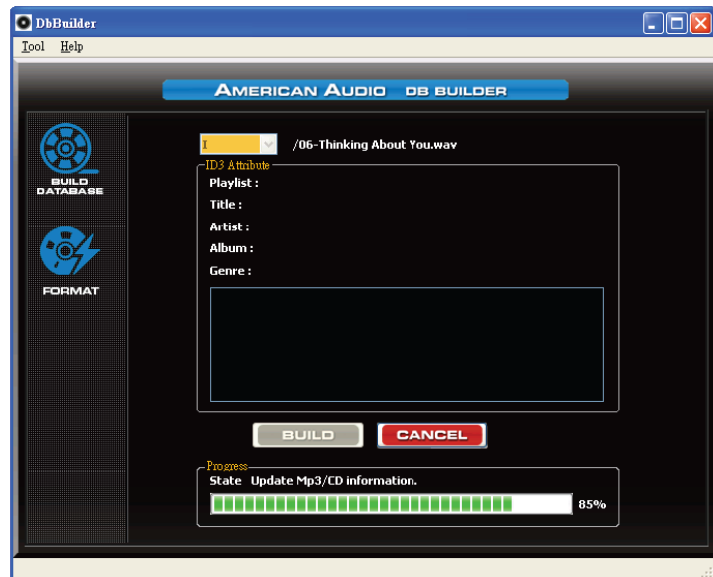

HOW TO CREATE A DATABASE FILE

1. Select your desired device.
2. Select *Build Database* in the left column.
3. Click *Build*.

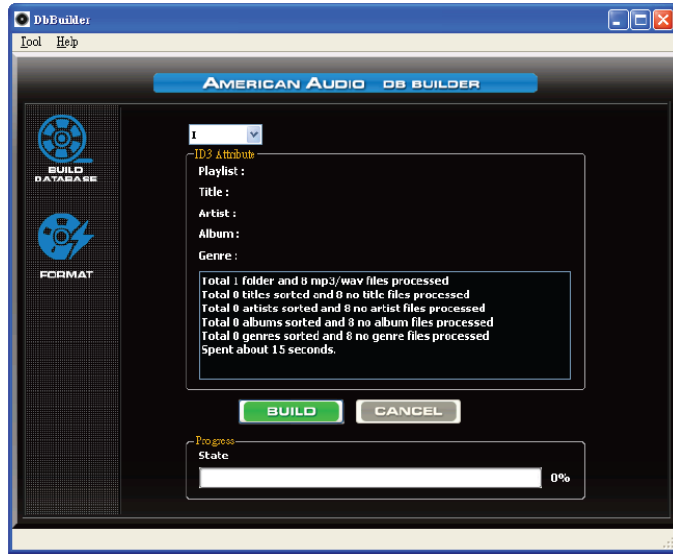

POSSIBLE ERRORS

- **Failed to Open Device:** Your drive is a non-supported format.
- **File Error:** This is due to MP3 file not have an identified ID3 tag.

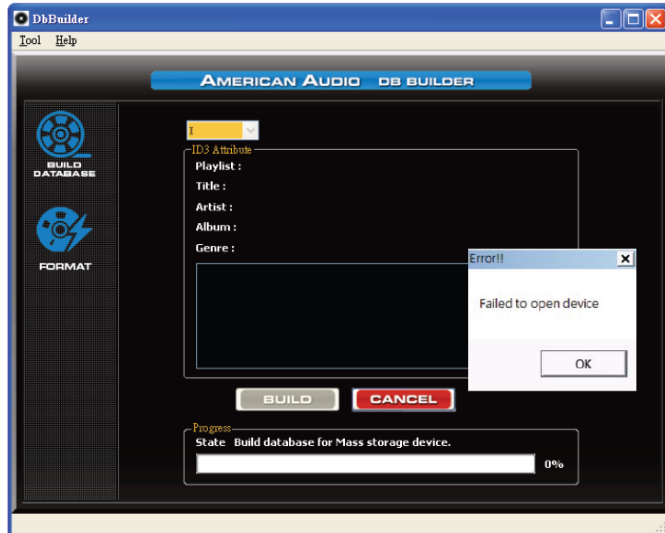

Windows 7/Vista may warn you according to your security settings.

Select *Allow* if you wish to install the database builder program.

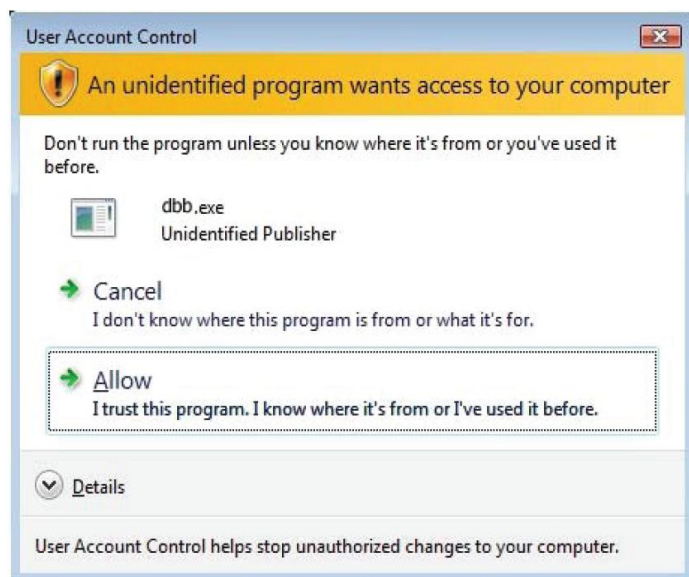

SET UP

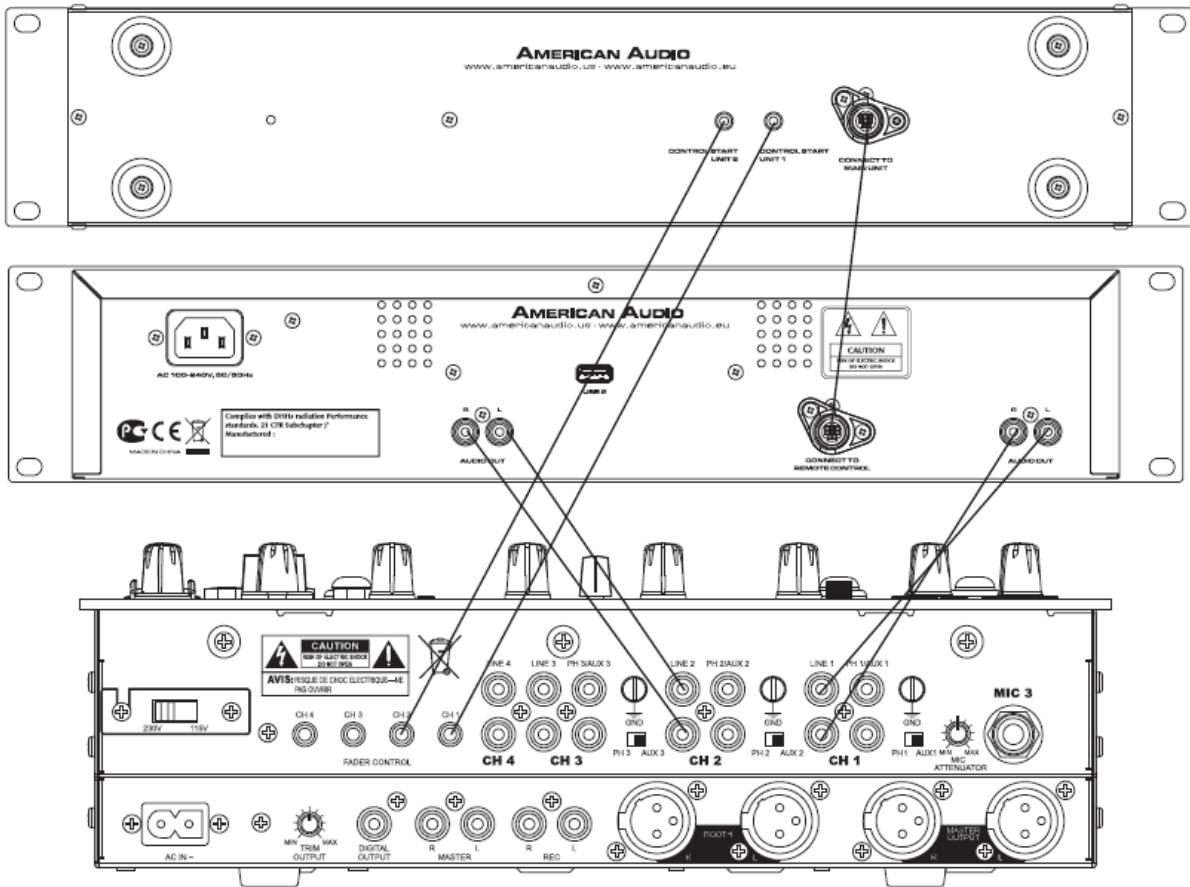

TROUBLESHOOTING

DISC READ ERROR

The disc is unable to read in the CD drive.

- Make sure that the disc is clean and not scratched. If the problem continues, try a different CD.
- Make sure that the CD is CDA or MP3 format.

If the disk takes over 20 seconds or more to read the CD lens will stop reading, this means the disc TOC was unreadable. Try another disk or clean the troubled disc. If problems continue with CD drives call American DJ service.

USB DEVICE NOT READING

When using Hard Drives, it is recommended that you use a hard drive with an external power supply or one that does not exceed 5 volt power consumption. If your hard drive resets itself when plugged into the USB ports on the UCD-100/200, you may need an external power supply. Contact your device manufacturer for accessory information. If the drive doesn't read the device, make sure that your device is formatted to a compatible FAT format.

WARNING — *DO NOT FORMAT YOUR DEVICE WITH OUT BACKING UP YOUR FILES.*

MUSIC FILES NOT FOUND IN USB DEVICE OR DATABASE

- Make sure that the file is an MP3 file.
- If it does not show up on the database modes (Album; Artist; etc.) use the database builder to update you library.

FILE ERROR WHEN BUILDING DB FILE

Remove the file that causes the database builder to stop and try again, if problem continues remove the folder and try again.

BEFORE SWITCHING OFF THE POWER

- When you have finished using the CD unit, and before switching off the power, be sure that the disc holder has been closed with the OPEN/CLOSE button.
- Tray Protection: If tray is not closed after 60 seconds, it will close automatically and pause.

CAUTION: Do not forcibly close the disc holder when the power is off.

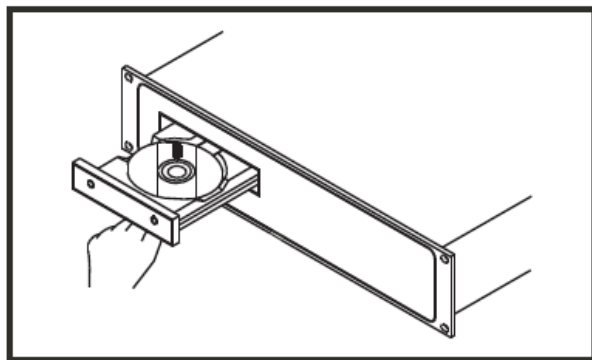

Do not switch off the power when the disc holder is open.

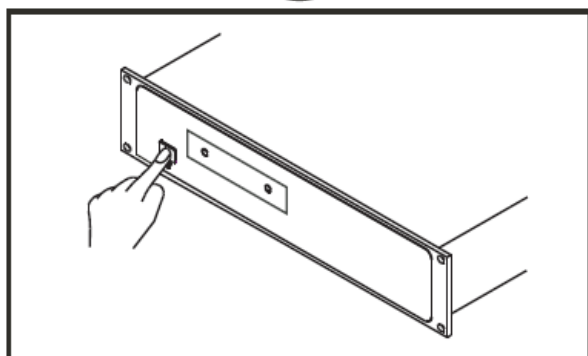

Switch off the power after the disc holder has been closed with the OPEN/CLOSE button.

Note: To avoid damage, please don't switch off the power until "no disc" or "time code" is showed on the LCD after the disc holder has been closed with the OPEN/CLOSE button.

COMPACT DISC

PRECAUTIONS ON HANDLING COMPACT DISCS

Compact discs are constructed of the same types of plastic records are. To avoid severe damage to your valuable discs please observe the following guide lines. Following these guide lines will ensure long disc life.

- Do not allow fingerprints, oil or dust to get on the surface of the disc. If the disc is dirty, wipe it off with a soft dry cloth.
- Do not use benzene, thinner, water, record spray, electrostatic-proof chemicals, or silicone-treated cloths to clean discs.
- Always handle discs carefully to prevent damaging the surface; in particular when removing a disc from its edges.
- Do not bend the disc.
- Do not apply heat.
- Do not enlarge the hole in the center of the disc.
- Do not write on the label (printed side) with a hard tipped implement such as a pencil or ball point pen.
- Condensation will form if a disc is brought into a warm area from a colder one, such as outdoors in winter. Do not attempt to dry the disc with a hair dryer, etc.

PRECAUTION ON STORAGE

- After playing a disc, always unload it from the unit.
- Always store the compact disc in the jewel case, protecting from dirt or damage.

Do not place discs in the following areas:

- Areas exposed to direct sunlight for a considerable time.
- Areas subject to accumulation of dust or high humidity.
- Areas affected by heat from indoor heaters, etc.

ROHS – A GREAT CONTRIBUTION TO THE CONSERVATION OF ENVIRONMENT

The European Union has adopted a directive on the restriction / prohibition of the use of hazardous substances. This directive, referred to as ROHS, is a frequently discussed topic in the electronic industry.

It restricts, among other things, six materials: Lead (Pb), Mercury (Hg), hexavalent chromium (CR VI), cadmium (Cd), polybrominated biphenyls as flame retardant (PBB), polybrominated diphenyl, also a flame retardant (PBDE). The directive applies to nearly all electronic and electrical devices whose mode of operation involves electric or electromagnetic fields – in short: each kind of electronics we have around us in our households or at work.

As manufacturers of products of the brands of AMERICAN AUDIO, AMERICAN DJ, ELATION Professional and ACCLAIM Lighting, we are obligated to comply with the RoHS directive. Therefore, as early as two years prior to the directive coming into force, we started our search for alternative environmentally friendly materials and manufacturing processes.

Well before the RoHS directive took effect, all of our products were manufactured meeting the standards of the European Union. With regular audits and material tests we can still assure that the components we use are always RoHS-compliant and that the manufacturing process, as far as the state of technology allows, is environmentally friendly.

The ROHS directive is an important step to the protection of our environment. We, as manufacturers, feel obligated to make our contribution in this respect.

WEEE – WASTE OF ELECTRICAL AND ELECTRONIC EQUIPMENT

Every year thousands of tonnes of electronic components, which are harmful to the environment, end up at the waste disposals around the world. To ensure the best possible disposal or recovery of electronic components, the European Union has adopted the WEEE directive.

The WEEE-system (Waste of Electrical and Electronic Equipment) can be compared with the system of the “Green Spot”, which has been in use for several years. The manufactures have to make their contribution to the utilization of waste at the time they release the product. Money resources obtained by doing so will be applied to develop a common system of waste management. Thereby we can ensure professional and environmentally friendly scraping and recycling program.

As manufactures, we are part of the German system of EAR and we make our contribution towards it.

(Registration in Germany: DE41027552)

That means that products of AMERICAN DJ and AMERICAN AUDIO can be left in the collection points free of charge and they will be used in the recycling program. Products of ELATION Professional, which are used only by professionals, shall be handled by us. Please send Elation products directly to us at the end of their lifetime so that we can professionally dispose of them.

Like the above ROHS, the WEEE directive is an important contribution to the environment protection and we are glad to help to clean the environment with this disposal system.

We are happy to answer any of your inquiries and welcome your suggestions at:
info@americandj.eu

SPECIFICATIONS

GENERAL

Model:	American Audio® UCD-200 - Professional Compact Disc/USB Player
System:	Dual, CD Tray Loading, Digital Compact Disc Audio Player.
Disc Type:	Standard compact discs (5 in / 12 cm and 3 in / 8 cm discs)
Dimensions:	Player unit: 19" (W) x 3.49" (H) x 10.5" (D) 482mm (W) x 88.8mm (H) x 267mm (D) (without feet) Control unit: 19" (W) x 3.7" (H) x 3.5" (D) 482mm (W) x 94mm (H) x 91.2mm (D) (without feet)
Installation:	Place on flat surface or mount in flat case
Weight:	Player unit: 10.14 Lbs. / 4.6kgs Control unit: 3.75 Lbs. / 1.7kgs
Power Supply:	AC 100~240V, 50/60Hz
Power Consumption:	16W
Pitch Control Range:	+/-4%, +/-8%, +/-16%, +/-100% (100% only applies to Standard CD's)
Pitch Bend:	+/-4%, +/-8%, +/-16%, +/-100% (100% only applies to Standard CD's)
Pitch Accuracy:	0.1%
Environmental Conditions:	Operational temperature: 5 to 35°C (41 to 95°F)
Operational Humidity:	25 to 85% RH (non-condensation)
Storage Temperature:	-20 to 60°C (4 to 140°F) Control 1/8" miniplug type (3 feet)
Accessories:	Dual RCA Cable (for left and right channels)

AUDIO SECTION

Quantization:	16 bit linear per channel
Sampling Rate:	44.1 kHz at normal pitch
Over Sampling Rate:	8 times over sampling 1 bit D/A converter

D/A Conversion	16 bit
Frequency Response:	20Hz to 20KHz +/-0.4dB for CDDA
Output Level:	2.0V +/- 0.5dB
Load Impedance:	47k ohm or more

AUDIO CHARACTERISTICS

(Test disc: TCD-782 & 781; USB FORMAT: MP3, 128KBPS; LOAD=100Kohm):

Item	Nominal	Limit	Condition
Output level (CD)	2Vrms +/-0.5dB	2Vrms +/-1dB	1KHz,0dB
Output level (USB)	1.85Vrms +/-0.5dB	1.85Vrms +/-1dB	1KHz,0dB
Channel balance	Within 0.2dB	Within 1dB	1KHz,0dB
Freq. Response (CD)	17-20KHZ +/-0.4dB	17-20KHZ +/-1dB	0 dB Output (TCD782, TRK2/3/7)
Freq. Response (USB)	17-16KHZ +/-0.2dB	17-16FKHZ +/-1dB	0 dB Output (TCD781, TRK1/4/16)
De-emph. Response (CD)	-20dB +/-0.2dB	-20dB +/-0.2dB	16KHz, -20dB
Ch. Sep.*2 (CD/USB) (*2)	93dB	85dB	1KHz,0dB
T.H.D. + NOISE (CD) (*1)	0.008%	0.015%	1KHz,0dB
T.H.D. + NOISE (USB) (*1)	0.007%	0.015%	1KHz,0dB
S/N ratio (CD) (IHF-A) (*2)	126dB	90dB	1KHz,0dB
S/N ratio (USB)(IHF-A) (*2)	85dB	80dB	1KHz,0dB
Dynamic Range (CD) (*2)	92dB	88dB	1KHz.-60dB

Note: (*1) With 20 kHz low pass filter. (*2) With 20KHz low pass filter and "IHF-A" Weighted.

SEARCHING TIME

(Test disk: TCD-792)

Item	Nominal	Limit	Condition
Short access time	2 sec	4 sec	Play next track
Long access time	4 sec	6 sec	Track 1 => Track 20 / Track
CD recover time	1 sec	2 sec	CD play interrupted by mechanical shock

PLAYABILITY

Item	Nominal	Limit	Condition
Interruption	1mm	0.7mm	TCD-725
Black dot	1mm	0.6mm	TCD-725
Finger prints	75um	65um	TCD-725
Eccentricity	140um	140um	TCD- 712, W/O TRACK JUMP
Vertical deviation	1mm	0.5mm	TCD- 731R
Scratch	2mm	1.2mm	TCD- 721, W/O TRACK JUMP

PICK-UP

System: Object lens drive system optical pick-up

Object Lens Drive System: 2 dimensional parallel drive

Tracking Detection: 3 spot beam detection

Optical Source: Semiconductor laser

Wave Length: 780nm

Note:

*These specifications are subject to change to any improvement by negotiations in advance.
These parts are subject to change to any improvement within the range of the specifications.*

MP3 FORMAT

Disc Format	Applicable file extensions	mp3. MP3. mP3. Mp3
	ISO9660	Max. 63 characters
	Joliet	Max. 63 characters
	CD-ROM sector format	mode-1 only
	Max. number of Folders	255
	Max. number of files	Max. 999 files (see Note #1)
USB Format	File System	FAT 12/16/32
	Applicable file extensions	mp3. MP3. mP3. Mp3
	Max. number of Folders	999
	Max. number of files	Max. 999 files
MP3 Format	MPEG 1 Layer 3 standard (ISO/IEC 11172-3), which	32/40/48/56/80/96/112/128/160/192/22

	provides for single channel ('mono') and two-channel ('stereo') coding at sampling rates of 32, 44.1 and 48kHz.	4/256/320 kbps Xing/VBRI VBR
	MPEG 2 Layer 3 standard (ISO/IEC 13818-3), which provides for similar coding at sampling rates of 16, 22.05 and 24 kHz.	32/40/48/56/64/80/96/112/144/160 KbpsXing/VBRI VBR
	MPEG 2.5 Layer 3 standard, which provides for similar coding at sampling rates of 8, 11.025 and 12 kHz.	32/40/48/56/64/80/96/112/144/160 KbpsXing/VBRI VBR
Disc Writing Method	Disc at Once and Track at Once	
	Multi Session	If the 1st session is CDDA, you can playback Only CDDA track, If the 1stsession is MP3, you can playback only MP3 file.

Note #1: Max.255 files each folder



©American Audio® World Headquarters:
6122 S. Eastern Ave., Los Angeles, CA 90040 USA
Tel: 323-582-3322 Fax: 323-582-3311
Web: www.americanaudio.us E-mail: info@americanaudio.us