

elumen8

Evora 500 Spot User Manual



Order codes: ELUM022

WARNING

FOR YOUR OWN SAFETY, PLEASE READ THIS USER MANUAL CAREFULLY BEFORE YOUR INITIAL START-UP!

- Before your initial start-up, please make sure that there is no damage caused during transportation.
- Should there be any damage, consult your dealer and do not use the equipment.
- To maintain the equipment in good working condition and to ensure safe operation, it is necessary for the user to follow the safety instructions and warning notes written in this manual.
- Please note that damages caused by user modifications to this equipment are not subject to warranty.



IMPORTANT:

The manufacturer will not accept liability for any resulting damages caused by the non-observance of this manual or any unauthorised modification to the equipment.

- Never let the power cable come into contact with other cables. Handle the power cable and all mains voltage connections with particular caution!
- Never remove warning or informative labels from the unit.
- Do not open the equipment and do not modify the unit.
- Do not connect this equipment to a dimmer pack.
- Do not switch the equipment on and off in short intervals, as this will reduce the system's life.
- Only use the equipment indoors.
- Do not expose to flammable sources, liquids or gases.
- Always disconnect the power from the mains when equipment is not in use or before cleaning! Only handle the power-cable by the plug. Never pull out the plug by pulling the power-cable.
- Make sure that the available mains supply voltage is between 100~240V AC, 50/60Hz.
- Make sure that the power cable is never crimped or damaged. Check the equipment and the power cable periodically.
- If the equipment is dropped or damaged, disconnect the mains power supply immediately and have a qualified engineer inspect the equipment before operating again.
- If the equipment has been exposed to drastic temperature fluctuation (e.g. after transportation), do not connect power or switch it on immediately. The arising condensation might damage the equipment. Leave the equipment switched off until it has reached room temperature.
- If your product fails to function correctly, stop use immediately. Pack the unit securely (preferably in the original packing material), and return it to your Pro Light dealer for service.
- Only use fuses of same type and rating.
- Repairs, servicing and power connection must only be carried out by a qualified technician. THIS UNIT CONTAINS NO USER SERVICEABLE PARTS.
- This lighting fixture is for professional use only - it is not designed for or suitable for household use. The product must be installed by a qualified technician in accordance with local territory regulations. The safety of the installation is the responsibility of the installer. The fixture presents risks of severe injury or death due to fire hazards, electric shock and falls.
- Warning! Risk Group 2 LED product according to EN 62471. Do not view the light output with optical instruments or any device that may concentrate the beam.
- WARRANTY: Two years from date of purchase.

OPERATING DETERMINATIONS

If this equipment is operated in any other way, than those described in this manual, the product may suffer damage and the warranty becomes void. Incorrect operation may lead to danger e.g: short-circuit, burns and electric shocks etc.

Do not endanger your own safety and the safety of others!

Incorrect installation or use can cause serious damage to people and/or property.

Evora 500 Spot

The Evora 500 Spot features a 100W LED and sports a host of features inside its compact shell. A 3 facet, indexable rotating prism, remote focus and manual zoom combined with rich vibrant colours and 2 gobo wheels result in stunning light shows to fill any venue. 16 bit resolution and pan and tilt auto correction make this little mover ideal for rental and installations alike.

- 1 x 100W white LED
- Adjustable beam angle: 12° - 16°
- 12° - 26,000 Lux @ 2m, 16° - 14,000 Lux @ 2m
- 3.6kHz refresh rate
- Motorised focus
- 3 facet rotating indexable prism
- Gobo wheel 1: 6 rotating, indexable, replaceable gobos + open
- Gobo wheel 2: 8 static gobos + open
- Colour wheel: 8 colours + open
- DMX channels: 15
- RDM (Remote Device Management)
- Auto, sound active and master/slave modes
- Pan/tilt auto correction
- 16-Bit pan/tilt positioning
- Pan: 540°, Tilt: 270°
- 0-100% dimming and variable strobe
- Supplied with quick release omega clamp
- 6 push button menu with 1.8" LCD display
- PowerCON input/output
- 3-Pin XLR input/output
- 5-Pin XLR input/output
- Fan cooled

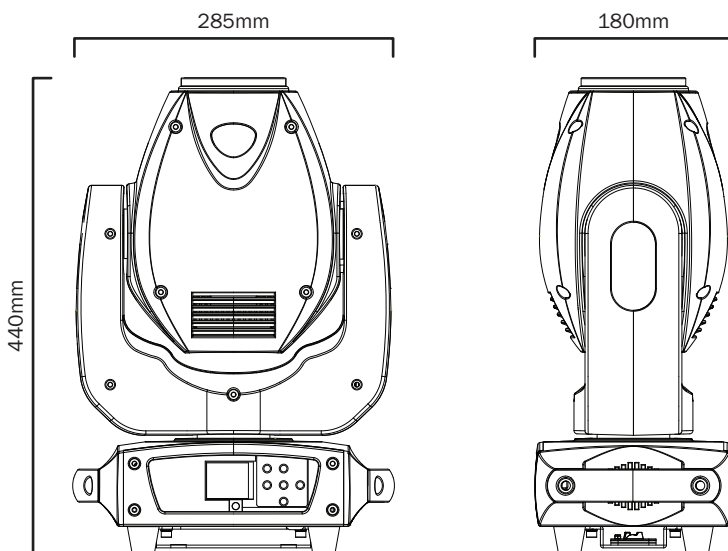

Specifications	Evora 500 Spot
Power consumption	175W
Fuse	T2A 250V
Power supply	100~240V, 50/60Hz
Dimensions	440 x 285 x 180mm
Weight	8.6kg
Order code	ELUM022

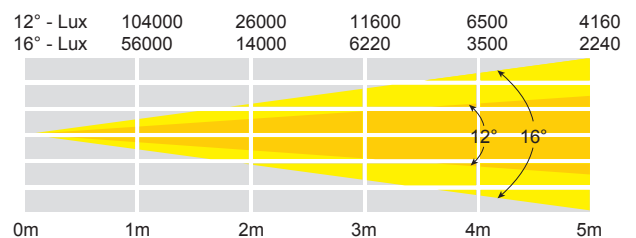

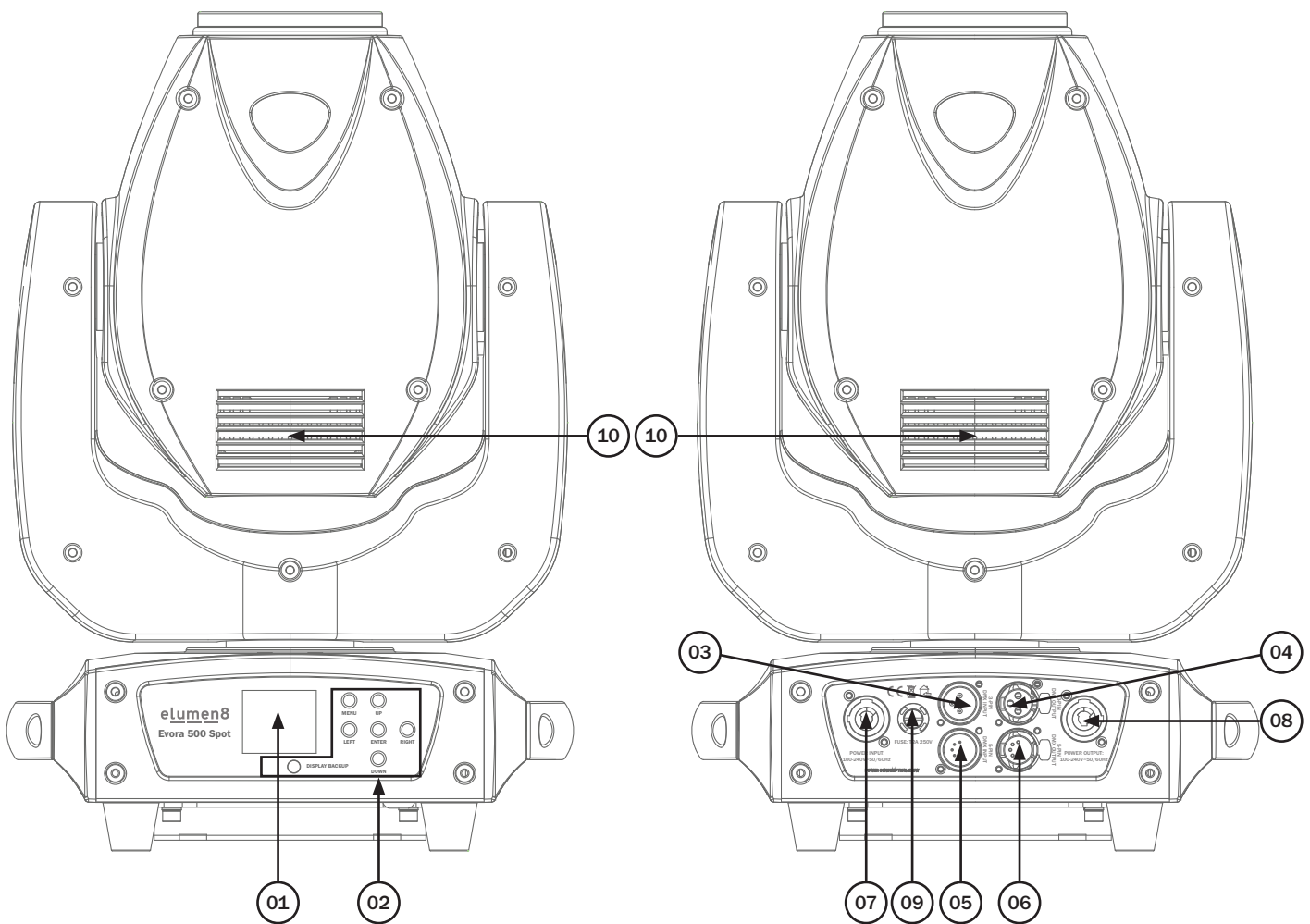

01 - LCD display
 02 - Function buttons
 03 - 3-Pin DMX input
 04 - 3-Pin DMX output

05 - 5-Pin DMX input
 06 - 5-Pin DMX output
 07 - PowerCON input
 08 - PowerCON output

09 - Fuse T2A 250V
 10 - Fans

In the box: **1 x fixture,**
1 x omega clamp,
1 x power cable
& 1 x user manual

Control Panel Menu:

The LCD control panel situated on the front of the fixture allows the user to access the menu system to adjust the fixtures settings.

When the unit has been powered on it will show “**Software Update Please Wait...**” followed by “**Motor Reset Please Wait...**” and “**eLumen8 Evora 500 Spot**”. The fixture will then return to its home screen.

Pressing the “**MENU**” button once will take the user to the fixtures main menu. Using the “**UP**” and “**DOWN**” buttons you can then navigate between the different options in the main menu. Pressing the “**ENTER**” button on one of these options allows you to access the sub menu where you can use the “**LEFT**” and “**RIGHT**” buttons to select option/value required. Once the option/value has been selected press the “**ENTER**” button once more to confirm the setting.

To exit out of any of the above options, press and hold the “**MENU**” button.

The LCD control panel can be used via the internal battery. To access this press and hold the “**DISPLAY BACKUP**” button for 5 seconds until the fixtures home screen is displayed. The LCD display will automatically shut off after 20 seconds of inactivity.

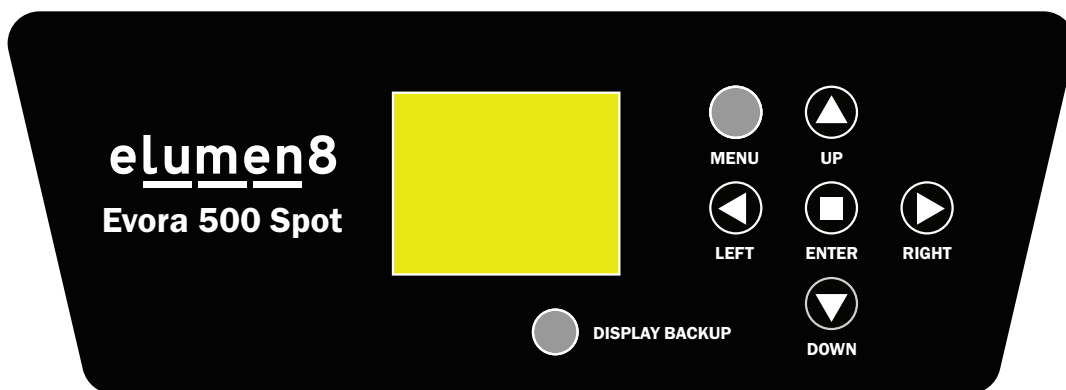

Error Codes:

When the unit is powered on the unit will automatically perform a motor reset. If there is a problem with one or more of the motors the display will flash 5 times and display “**pan/tilt error**” on the LCD control panel. Please power the unit off and on to reset the motors again.

Offset Menu:

To access the units offset menu press the “**MENU**” button once to display “**DMX Address**” on the LCD display. Press and hold the “**ENTER**” button until the offset menu is displayed.

Offset Menu	Options/Values (Default Settings in BOLD)	Description
Pan Offset	-128-127 (000)	Pan Offset
Tilt Offset	-128-127 (000)	Tilt Offset
Color Offset	-128-127 (000)	Color Offset
Gobo1 Offset	-128-127 (000)	Gobo Wheel 1 Offset
RGobo1 Offset	-128-127 (000)	Gobo Wheel 1 Rotation Offset
Gobo2 Offset	-128-127 (000)	Gobo Wheel 2 Offset
Prism Offset	000-255 (000)	Prism Offset
RPrism Offset	-128-127 (000)	Prism Rotation Offset
Focus Offset	000-255 (000)	Focus Offset

Main Menu	Sub Menu	Options/Values (Default Settings in BOLD)	Description
DMX Address		001 -512	DMX Address Setting
Channel Mode		15Chan (15 channel mode)	DMX Channel Setting
Show Mode		Show 1 Show 2 Show 3 Show 4	Show Modes
Split Color		No (AUTO def.) Yes (PRO def.)	Split Colour Setting
Slave Mode		Slave 1 (PRO & AUTO def.) Slave 2	Slave Mode
Black out		No (AUTO def.) Yes (PRO def.)	Blackout
Sound State		On (AUTO def.) Off (PRO def.)	Sound Setting
Sound Sense		000-100 (090) (PRO & AUTO def.)	Sound Sensitivity Setting
Pan Inverse		No (PRO & AUTO def.) Yes	Pan Inverse Setting
Tilt Inverse		No (PRO & AUTO def.) Yes	Tilt Inverse Setting
Back Light		On (AUTO def.) Off (PRO def.)	Back Light Setting
Focus Adjust		000-255 (016)	Gobo Wheel 1 Focus Setting
Focus2 Adjust		000-255 (061)	Gobo Wheel 2 Focus Setting
FunctionDelay		No Delay (AUTO def.) 1S Delay 2S Delay 3S Delay (PRO def.)	Function Delay Setting
DimmerCalibr.		050- 100	Dimmer Calibration
Auto Test		Testing	Auto Test
Temp.		---C	Fixture Temperature
Fixture Time		--h	Fixture Run Time
Firmware Ver.		V0.01F	Software Version
Defaults	No Yes	PRO def. AUTO def.	Default Settings
Reset		No Yes	Motor Reset

15 channel mode:

Channel	Value	Function
CH1	000-255	Pan adjustment 0-540°
CH2	000-255	Pan fine adjustment
CH3	000-255	Tilt adjustment 0-270°
CH4	000-255	Tilt fine adjustment
CH5	000-255	Pan/tilt speed
CH6	000-255	Master dimmer (0-100%)
CH7	000-007	LED off
	008-015	LED on
	016-131	Strobe (slow-fast)
	132-139	LED on
	140-181	Strobe ramp up (slow-fast)
	182-189	LED on
	190-231	Strobe ramp down (slow-fast)
	232-239	LED on
	240-247	Random strobe (slow-fast)
	248-255	LED on
CH8 (when split colour is disabled in the menu - see page 6)	000-014	Open (white)
	015-028	Red
	029-042	Orange
	043-056	Yellow
	057-070	Green
	071-084	Cyan
	085-098	Blue
	099-112	Purple
	113-127	Hot Pink
	128-189	Colour scroll CW (fast-slow)
190-193	Colour scroll stop	
194-255	Colour scroll CCW (slow-fast)	

Channel	Value	Function
CH8 (when split colour is enabled in the menu - see page 6)	000-007	Open (white)
	008-014	Split colour (Open/Red)
	015-022	Red
	023-029	Split colour (Red/Orange)
	030-037	Orange
	038-044	Split colour (Orange/Yellow)
	045-052	Yellow
	053-059	Split colour (Yellow/Green)
	060-067	Green
	068-074	Split colour (Green/Cyan)
	075-082	Cyan
	083-089	Split colour (Cyan/Blue)
	090-097	Blue
	098-104	Split colour (Blue/Purple)
	105-112	Purple
	113-119	Split colour (Purple/Hot Pink)
	120-127	Hot Pink
	128-189	Colour scroll CW (fast-slow)
	190-193	Colour scroll stop
	194-255	Colour scroll CCW (slow-fast)
CH9	000-007	Open
	008-015	Rotating gobo 1
	016-023	Rotating gobo 2
	024-031	Rotating gobo 3
	032-039	Rotating gobo 4
	040-047	Rotating gobo 5
	048-063	Rotating gobo 6
	064-073	Gobo 1 shake (slow-fast)
	074-082	Gobo 2 shake (slow-fast)
	083-091	Gobo 3 shake (slow-fast)
	092-100	Gobo 4 shake (slow-fast)
	101-109	Gobo 5 shake (slow-fast)
	110-127	Gobo 6 shake (slow-fast)
	128-189	Gobo wheel scroll CW (fast-slow)
	190-193	Gobo scroll stop
	194-255	Gobo wheel scroll CCW (slow-fast)

15 channel mode cont.:

Channel	Value	Function
CH10	000-127	Gobo rotation index
	128-189	Gobo rotation CW (fast-slow)
	190-193	Rotation stop
	194-255	Gobo rotation CCW (slow-fast)
CH11	000-007	Open
	008-014	Static gobo 1
	015-021	Static gobo 2
	022-028	Static gobo 3
	029-035	Static gobo 4
	036-042	Static gobo 5
	043-049	Static gobo 6
	050-056	Static gobo 7
	057-063	Static gobo 8
	064-071	Gobo 1 shake (slow-fast)
	072-079	Gobo 2 shake (slow-fast)
	080-087	Gobo 3 shake (slow-fast)
	088-095	Gobo 4 shake (slow-fast)
	096-103	Gobo 5 shake (slow-fast)
	104-111	Gobo 6 shake (slow-fast)
	112-119	Gobo 7 shake (slow-fast)
	120-127	Gobo 8 shake (slow-fast)
	128-189	Gobo wheel scroll CW (fast-slow)
	190-193	Gobo scroll stop
	194-255	Gobo wheel scroll CCW (slow-fast)
CH12	000-007	Open
	008-255	3 facet prism
CH13	000-127	Prism indexing
	128-189	Prism rotation CCW (fast-slow)
	190-193	Prism rotation stop
	194-255	Prism rotation CW (slow-fast)
CH14	000-255	Focus

Channel	Value	Function
CH15	000-069	Disable all
	070-079	Enable blackout whilst pan/tilt
	080-089	Disable blackout whilst pan/tilt
	090-099	Enable blackout whilst colour changing
	100-109	Disable blackout whilst colour changing
	110-119	Enable blackout whilst gobo changing
	120-129	Disable blackout whilst gobo changing
	130-199	No function
	200-209	Reset motors
	210-249	No function
	250-255	Sound active (CH6 and CH7 must be at 255)

Rotating gobos:

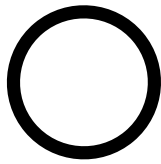

Open

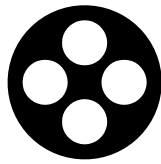

Gobo 1



Gobo 2

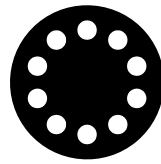

Gobo 3



Gobo 4



Gobo 5



Gobo 6

Static gobos:

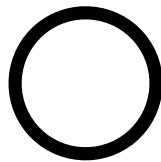

Open

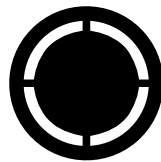

Gobo 1

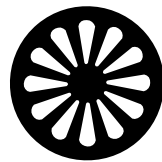

Gobo 2

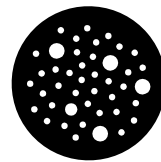

Gobo 3



Gobo 4



Gobo 5



Gobo 6

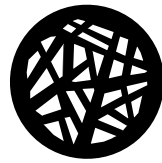

Gobo 7



Gobo 8

Setting the DMX address:

The DMX mode enables the use of a universal DMX controller. Each fixture requires a “start address” from 1- 511. A fixture requiring one or more channels for control begins to read the data on the channel indicated by the start address. For example, a fixture that occupies or uses 7 channels of DMX and was addressed to start on DMX channel 100, would read data from channels: 100,101,102,103,104,105 and 106. Choose a start address so that the channels used do not overlap. E.g. the next unit in the chain starts at 107.

DMX 512:

DMX (Digital Multiplex) is a universal protocol used as a form of communication between intelligent fixtures and controllers. A DMX controller sends DMX data instructions from the controller to the fixture. DMX data is sent as serial data that travels from fixture to fixture via the DATA “IN” and DATA “OUT” XLR terminals located on all DMX fixtures (most controllers only have a data “out” terminal).

DMX linking:

DMX is a language allowing all makes and models of different manufactures to be linked together and operate from a single controller, as long as all fixtures and the controller are DMX compliant. To ensure proper DMX data transmission, when using several DMX fixtures try to use the shortest cable path possible. The order in which fixtures are connected in a DMX line does not influence the DMX addressing. For example; a fixture assigned to a DMX address of 1 may be placed anywhere in a DMX line, at the beginning, at the end, or anywhere in the middle. When a fixture is assigned a DMX address of 1, the DMX controller knows to send DATA assigned to address 1 to that unit, no matter where it is located in the DMX chain.

DATA cable (DMX cable) requirements (for DMX operation):

This fixture can be controlled via DMX-512 protocol. The DMX address is set on the back of the unit. Your unit and your DMX controller require a standard 3-pin XLR connector for data input/output, see image below.



Further DMX cables can be purchased from all good sound and lighting suppliers or Pro Light Concepts dealers.

Please quote:

CABL10 – 2m

CABL11 – 5m

CABL12 – 10m

Note: DMX cable must be daisy chained and cannot be split.

Notice:

Be sure to follow the diagrams below when making your own cables. Do not connect the cables shield conductor to the ground lug or allow the shield conductor to come in contact with the XLRs outer casing. Grounding the shield could cause a short circuit and erratic behaviour.

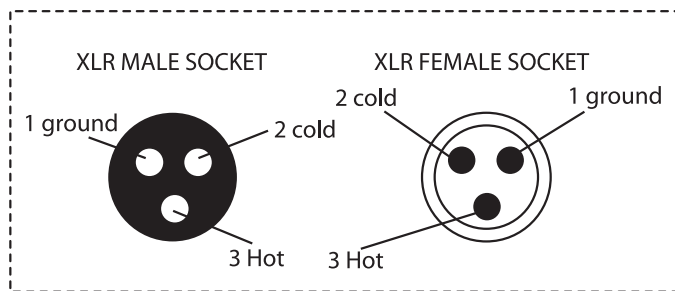
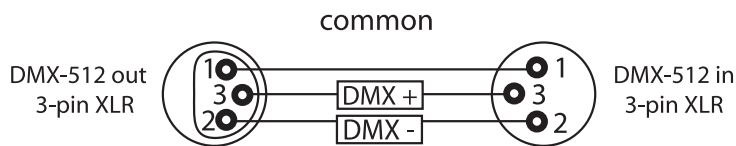

XLR Pin Configuration
Pin 1 = Ground
Pin 2 = Negative
Pin 3 = Positive

Special note:

Line termination:

When longer runs of cable are used, you may need to use a terminator on the last unit to avoid erratic behaviour.

Using a cable terminator will decrease the possibilities of erratic behaviour.

(3-pin - Order ref: CABL90, 5-pin - Order ref: CABL89)

Termination reduces signal transmission problems and interference. It is always advisable to connect a DMX terminal, (resistance 120 Ohm 1/4 W) between pin 2 (DMX-) and pin 3 (DMX+) of the last fixture.

5-pin XLR DMX connectors:

Some manufactures use 5-pin XLR connectors for data transmission in place of 3-pin. 5-pin XLR fixtures may be implemented in a 3-pin XLR DMX line. When inserting standard 5-pin XLR connectors in to a 3-pin line a cable adaptor must be used. The diagram below details the correct cable conversion.

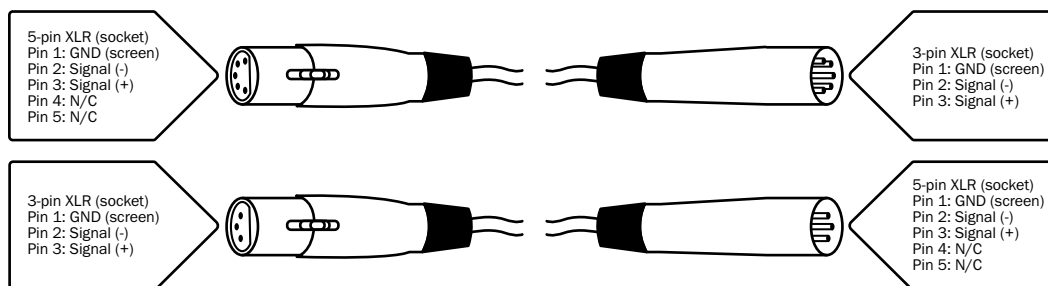



***Correct Disposal of this Product
(Waste Electrical & Electronic Equipment)***

(Applicable in the European Union and other European countries with separate collection systems)

This marking shown on the product or its literature, indicates that it should not be disposed with other household wastes at the end of its working life. To prevent possible harm to the environment or human health from uncontrolled waste disposal, please separate this from other types of wastes and recycle it responsibly to promote the sustainable reuse of material resources.

Household users should contact either the retailer where they purchased this product, or their local government office, for details of where and how they can take this item for environmentally safe recycling.

Business users should contact their supplier and check the terms and conditions of the purchase contract. This product should not be mixed with other commercial wastes for disposal.

