

# **USER MANUAL**

## **MULTISPOT G-II-HS5034**

High-Power DMX-Controlled LED light source

For firmware 50-010-0088-00113-1-03 MS GII HS5034 RevN



Updated versions of this document may be available at  
**[WWW.MULTIFORM-LIGHTING.COM](http://WWW.MULTIFORM-LIGHTING.COM)**

RevB 08/2013 Order code: 12-010-0083-80101-1-01

## ■ Introduction

Dear customer,

congratulations on the purchase of a Multiform-branded item and the trust having been put in us with this decision. Multiform is one of the leading global manufacturers of professional lighting equipment and has decades of experience in design, production and quality assurance.

To meet your requirements, this unit has been designed and built to the highest standards, so that we can assure you that you have made a good and satisfying investment. To take full advantage of all possibilities and for your own safety and the safety of your environment, please read these operating instructions carefully before you start using the unit.

## ■ Description

The Multispot GII is a high-power DMX-controlled LED light source for both indoor and outdoor applications, which range from architectural illumination to stage lighting. Available in various LED configurations, this fixture has been designed for flexibility and reliability, which includes various connection options and an advanced cooling system allowing for longer LED lifetime.

## SAFETY INFORMATION



**Read the safety precautions in this chapter before installing, powering up, operating or servicing this device. Failure to do so may void the product warranty, and releases the manufacturer from all product liability.**

## ■ Symbols used in this manual

The following symbols are used to identify important safety information on the product and in this manual:



**WARNING!** Read manual before installation, operation or servicing.



**WARNING!** Safety hazard. Risk of injury or death.



**WARNING!** Hazardous voltage. Risk of severe or fatal electric shock.

■ **Maintenance**

This device does not need regular maintenance. It is protected by an internal fuse located on the power supply PCB. If this fuse fails, this usually indicates an internal fault requiring servicing by a qualified engineer. The fuse shall only be replaced by a fuse of same specification, and the replacement has to be made by qualified personnel obeying applicable safety rules.

■ **Technical data MULTISPOT-GII-HS5034**

Panels/Output.....	1 panel, 2600 lmLEDs per panel: 34×1/3W 1-chip
Arrangement.....	8×1W red 6×3W green 6×3W blue 8×1W amber 6×3W white chip
Optics.....	Secondary, 25 degrees
DMX Control.....	3-7 Channels
IP Rating.....	20 (indoor)/65 (outdoor)
Mains Input.....	AC90-250V~ 50/60Hz
Power supply type.....	switch mode
Power consumption.....	75W
Fuse.....	internal (see service manual)
DMX connections.....	3 pin XLR (Male / Female)
Modulation Type.....	Pulse Density Modulation (PDM)
Control protocol.....	DMX 512 (1990)
Dimensions (with straight bracket) WxHxD.....	330.0 x327.0 x151.5mm
Weight.....	7.1kg

■ **Standards**

This product complies with the following standards:

EU electrical safety.....	EN60598-1:2008, EN60598-2-1:1989
EU general safety.....	EN60598-2-17
EU photobiological safety.....	EN 62471:2008
EU EMC.....	EN55015: 2006 + A1:2007, EN61547:1995 + A1:2000
EU Harmonics .....	EN61000-3-2:2006
EU Flicker .....	EN61000-3-3:2008
US safety .....	UL60065
US EMC.....	FCC Part 15

This product meets both the EMC Directive 2004/108/EC and the Low Voltage Directive 2006/95/EC.



**WARNING!** Shock hazard. Equipment must be properly grounded.



**WARNING!** Hot surface. Risk of skin burn or skin irritation.



**WARNING!** Fire hazard.



**WARNING!** Laser radiation. Risk of surface damage.



**WARNING!** LED light emission. Risk of eye injury.

■ **Security advice before use**



**General advice:**

1. Read this manual completely before using the product.
2. Keep this manual in your records for future reference.
3. Follow all instruction printed in this manual.
4. Follow all printed security advice on the product itself.
5. Take care of enough distance between this product and sources of hum and noise like electric motors and transformers.
6. Carry this product with greatest care. Punches, big forces and heavy vibration may damage this product mechanically.



**Protection from eye injury**

1. Warning: Depending on the configuration of the device, this device may reach or exceed the limits of EN62471, risk group 2, and may hence reach to risk group 3.
2. To avoid eye injury, do not look into the beam from a distance of less than 8.5 m (27 ft. 11 ins) from the front surface of the fixture without protective eyewear such as shade-5 welding goggles. At larger distances, light output is harmless to the naked eye provided that the eye's natural aversion response is not affected.
3. Do not view the beam directly with optical instruments such as magnifiers, telescopes, binoculars or similar optical instruments that may concentrate the light output.
4. Ensure that during setup and DMX programming, no persons are inside a 8.50m (27 ft. 11 ins) vicinity of the device's front surface, to avoid that they may accidentally be exposed to the light beam.

**Protection from electric shock:**

1. Only connect this unit to a mains socket outlet with protective earth connection, ground-fault (earth-fault) and overload protection.
2. Where the mains plug or an appliance coupler is used as a disconnect device, such device shall remain readily operable.
3. To pull the AC Cord out of the wall outlet or the unit's AC socket, never pull the cable itself, but only the AC plug.
4. Disconnect the unit from AC supply before any kind of cleaning on the product. Use smooth and dry cloth only for cleaning.
5. Do not expose this unit to any dripping or splashing liquids, and do not place objects filled with liquids, such as vases, on the unit.
6. Do not operate this unit near to open water or in high humidity.
7. Choose the position of the AC cord according to the lowest risk of damage by foot steps or by squeezing it.
8. Do not open the unit for service, there are no user-serviceable parts inside. Warranty will be void in any case of unauthorized service by the user or other not authorized persons.

**Protection from fire:**

1. Take care of not placing the unit near sources of heat (e.g. powerful amplifiers, fog machines).
2. Allow at least about 0.15m (6 ins.) between this unit and other devices or a wall to allow for proper cooling.
3. Take always care of sufficient air convection in the unit's environment to avoid overheating. Make sure air convection slots are not blocked. Do not operate this unit in environmental temperatures exceeding 40 degrees Celsius.
4. Be sure this fixture is kept at least 0.75m (30ins.) away from any flammable materials (decoration etc.).
5. Do not stick filters, masks or other materials directly on the LEDs or the LED cover screen.
6. Check the total maximum power of your AC wall outlet if you connect several units to one wall outlet and avoid any overloading.
7. If the device itself has an AC outlet for providing power to other units, make sure to not exceed the specified maximum load.

**Protection from injury and damage:**

1. Never use any accessories or modifications not authorized by the manufacturer of this unit.
2. Choose a location for operation where the unit is protected from vibration and where a fixed mounting position is provided. In case of overhead-mounting, follow applicable rigging requirements.
3. Before plugging the AC cord in the wall outlet, check whether the AC plug, the mains voltage and frequency are the same as this product is specified for. If not, contact you dealer immediately.

used together to do not exhibit different color behaviour, please make sure that all fixtures used together are calibrated to the same color behaviour.

**■ EDIT**

**Automatic DMX addressing.** This allows to use the first device in a row of units connected via DMX to be used as a master unit and set all subsequent units' DMX address automatically. On the first (master) unit, in EDIT menu, use the left/right arrows until the display shows "ADMX". You can now decide to either address all subsequent units in GDMX mode with the same channel scheme as on the master unit, but consecutive DMX addresses for individual control; or to set all subsequent units to SLAVE mode for mutual control. To enable GDMX auto addressing, press the + button to start the auto addressing process and keep it pressed; the display will show "GDMX" when done. To enable SLAVE auto addressing, press the - button to start the auto addressing process and keep it pressed; the display will show "SLAVE" when done.

**Auto Lock.** Use the left/right arrows until the display shows ALOK. Press any of the +/- button to alternate between "on" or "off". When on, the unit will lock itself after more than 1 minute of no use of the UI. When off, the UI will remain unlocked. To unlock a locked unit, press the left and the right arrow buttons simultaneously.

**Auto Display off.** Use the left/right arrows until the display shows ADIS. Press any of the +/- button to alternate between "on" or "off". When on, the unit will disable the LCD backlight after more than 1 minute of no use of the UI. When off, the display backlight will remain enabled. Note: The display elements themselves remain active.

**Temperature Display.** Use the left/right arrows until the display shows "TEMP". Press any of the +/- button to alternate between "on" or "off". When on, the unit will display the temperature in °C after more than 1 minute of no use of the UI.

**Reset.** Use the left/right arrows until the display shows "RSET". Press the + or the - button to enter the RESET MODE and the display will show 'YES+' Press the + button to activate a reset to the factory default settings and calibration (the - button is disabled in this menu). For confirmation, the LED panel flashes once. The reset excludes the operation hours.

**Operation Hours.** Use the left/right arrows until the display shows HOUR. Press the - button and the display will show the operating hours up to 9999 hours. Operating hours exceeding the first 9999 hours can be extracted from the unit via RDM by a qualified service technician.

**FW Version.** Use the left/right arrows until the display shows VERS. Press either of the -/+ buttons to have the display showing the firmware version.

button is pressed the relative settings become active. The display will only show the values presently being viewed or changed. After 30 sec. of no alterations or if the MODE button is pressed the display returns to show "GDMX".

IN PRES (preset mode), the channel assignment is as follows:

CH1 = 000-255: Color presets ST1....ST25 as in Static Color Mode [If CH3 < 050]  
 CH1 = 000-127: Fade presets FP0...FP7 as in Switch Pattern Mode [If CH3 ≥ 050]  
 CH1 = 128-255: Fade presets SP0...SP8 as in Fade Pattern Mode [If CH3 ≥ 050]

CH2 = 000-255: Master Dimmer 0-100%

CH3 = 000-049: Color preset mode selection (color by CH1)  
 CH3 = 050-255: Pattern preset mode selection and speed setting (pattern by CH1)

CH4 = 000-049 Strobe off  
 CH4 = 050-255 Strobe with adjustable speed (050=slow / 255=max. speed)

**NOTE:** Whenever a DMX signal is received, the "D" tab in the display is lit – this is valid for all DMX-related modes.

The DMX channel setting is global – if you change the control mode/channel scheme later, the DMX start address will remain valid, but the number of consumed channels may change.

DO NOT try to leave the control mode/channel scheme choice by pressing the left/right arrow buttons; this would change the control mode/channel scheme to the next subsequent choice. Always leave this mode by either pressing the MODE button or by simply waiting until the display returns to show "GDMX".

### ■ COLOR BALANCE

In this Mode you can define your individual fixture's Color Balance by setting a maximum brightness for each LED colour giving you the individual color balance you desire. Press the MODE button until the display shows "CBAL". Use the left/right arrow buttons to select any of the following options: „Rxxx“, „Gxxx“, „Bxxx“, „Axxx“ and „Wxxx“ with „xxx“ being values between 200 and 255. Value settings below 200 are disabled to avoid unwanted output reduction of the fixture. If you want to change the maximum output of the colour being displayed use the +/- buttons to do so. For control purposes all LED's are lit with their chosen maximum value. All changes made become effective immediately. If pressing the MODE button during editing a color level, the display returns to 'CBAL'.

Note: Any settings made in this mode will influence the overall color balance of the fixture (in all available operation modes – also DMX). To make sure that several fixtures

4. The surface of the device may get hot during operation, and heat sink areas may reach to or exceed the limits of EN60950. Do not touch heat sink areas of the device during operation, and allow 20 minutes of cool-down time after powering off before touching.
5. If fluids have spilled into the unit or small parts have intruded the unit, immediately switch off the unit and hand it over to the authorized service for a security check.
6. Disconnect the unit from AC supply by pulling the AC plug out of the wall outlet or the unit's AC socket during a thunder-storm in order to avoid any damage on the unit due to AC voltage peaks.
7. In case of not correct function of this unit or damaged AC cord or other damaged parts, pull immediately the AC plug out of the wall outlet and hand the unit over to the authorized service for a security check.
8. To meet all aspects of functionality and security during maintenance work to be performed on this unit, all parts should be replaced by genuine spare parts. Consequently, take care of your dealer or maintenance company to be authorized by the manufacturer.

### ■ Health advice

This unit produces and absorbs electromagnetic radiation. The strength of radiation and the sensitivity for disturbing interference matches the CE and FCC requirements. A corresponding sign is printed on the backside of the unit. Any change or modification may affect the behavior of the unit concerning electromagnetic radiation, with the CE requirements eventually not to be met any more. The manufacturer takes no responsibility in this case.

### ■ Functional advice

This unit is immune to the presence of electromagnetic disturbances – both conducted and radiated - up to a certain level. Under peak conditions, the unit is classified to show a "class C" performance criteria and may encounter temporary degradation or loss of function which may need manual help to recover. In such case, disconnect the AC power from the unit and reconnect it again to recover.

### ■ Environmental advice



This unit is built to conform to the ROHS standards and the WEEE directive 2002/96/EC of the European Parliament and of the Council of the European Union. Under these regulations, the product shall not be discarded into regular garbage at the end of its life, but shall be returned to authorized recycling stations.

### ■ LED Lifetime advice

LED lifetime is determined by the gradually declining brightness of a LED over time, with a point of 50% brightness reduction marking the defined end of its lifetime. The driving factor of this effect is the heat that the chip inside the LED is exposed to. While a chip may under ideal circumstances reach to more than 100000 hours of lifetime, the real-world lifetime may only be 30000 to 50000 hours or less if the LED is exposed to excessive heat, which can be caused by continuously running all LEDs inside this device at full power and operating the unit in high environmental temperatures. If improving the lifespan expectancy is a priority, take care of providing for lower operational temperatures. This may include forced external cooling and/or the reduction of overall projection intensity.

### ■ Unpacking

Please check that the box contains the following items, and contact your dealer immediately for replacement if any part is missing:

Main parts:                    1 pc. MULTISPOT-GII-HS5034 LED main unit  
    1 pc. operation manual

### ■ Getting started: changing the connectors (only if required)

Your MULTISPOT-GII-HS5034 has been factory-fitted with connectors for both AC In/Out and DMX In/Out. This configuration can be changed with comparatively little effort into an IP65-compliant outdoor version, with PG9 cable glands to hold all connection cables in a waterproof manner.



**Reliability risk:** Changing the connectors in an inappropriate manner may defeat the waterproof capabilities of the fixture and may void any warranty of the manufacturer if water intrudes into the unit. It is essential to follow the below instructions to maintain the waterproof capabilities of the fixture and its product warranty subsequently.



**Safety risk:** This procedure requires to open the unit. In case of unintended connection to AC supply, life parts may be exposed and touchable. In case of wrong internal wiring, the safety of the whole installation where this unit is used may be endangered and a risk of fire is possible. This procedure shall hence only be carried out by qualified technicians with relevant experience in safe work methods for electrical equipment service and maintenance. DO NOT attempt to change the connectors by yourself if you do not have the applicable experience. The manufacturer does not take any liability for life and assets if such unqualified attempt is made.



SL11	1 loop per 6 seconds	SL24	2,8 loops per second
SL12	1 loop per 4 seconds	SL25	3,2 loops per second

Once the speed level is set and no changes done the display will return to show "FP0"... "FP7" after 5 seconds. The same happens if the pattern preset is changed by the left/right arrows, in this case the speed setting mode is left immediately and the speed will remain as last set.

### ■ DMX SLAVE MODE

Press the MODE button until the display shows "SLA", indicating that the unit works in slave mode. The unit will receive DMX commands on channels 1, 2 and 3. Please note that these 3 channels represent a common communication standard between all models of the Multispot-GII series and do not directly relate to the LED colors. The 3 channels carry RGB information which is internally re-calculated into the control information required for the specific units' LED arrangement. Hence, it is not recommended to use the SLAVE mode with any external controllers, since it has been specifically designed for setups where one Multispot-GII acts as a master and the others as slaves, while the different models of the range can be mixed. The attempt to use an external DMX controller as a master with all connected Multispot-GII set to SLA mode will deliver unexpected and/or confusing results - use the GDMX setting instead.

**NOTE:** Whenever a DMX signal is received, the "D" tab in the display is lit – this is valid for all DMX-related modes.

### ■ DMX GENERAL MODE / ADDRESS SETTING

Press the MODE button until the display shows "GDMX". By the first touch of the left or right arrow button the present DMX Mode will be displayed. Use these left/right arrow buttons to choose between any of the following color control modes/channel schemes:

- 3RAW = 3 colors RGB (3 channels)
- 3CCC = 3 colors RGB + combined master/strobe (4 channels, as old Multispot)
- 3CMS = 3 colors RGB + master + strobe (5 channels)
- 5RAW = 5 colors RGBWA (5 channels)
- 5CMS = 5 colors RGBWA + Master + strobe (7 channels)
- HSLS = Hue Saturation Lightness + strobe (4 channels)
- PRES = Presets (allows to recall the preset colours and programmes of the unit) (4 Channels, see assignment specification below)

Once having chosen the required control mode/channel scheme, please use the + or – buttons to set the required DMX address. Pressing the + or – button for the first time will show the present DMX address, which then can be altered by repeatedly using the +/- buttons in a range from 001 to 512. The display will show "1" ... "512" accordingly. Pressing the +/- buttons for longer than 1 second accelerates the change rate of the displayed value to 3 times. If no change is made for 0,5 sec. or longer or the MODE



Please note that above speed levels are only applicable to patterns SP0....SP08. For the strobe patterns, the following speed table applies:

Setting	Speed
S2L	Beatflash function: one flash per sound trigger (Strobe-to-Sound)
SL1..SL25	Strobe speed 1 Hz...18Hz

Choosing "S2L" activates the "Sound-to-Light" function shown by illuminating the "S" symbol in the display and displaying "S2L". The speed is now being driven by the beat of the music taken up by the built-in microphone.

Once the speed level is set or the S2L-function chosen and no changes done the display will return to show "SP0"... "SP12" after 5 seconds. The same happens if the pattern preset is changed by the left/right arrows, in this case the speed setting mode is left immediately and the speed will remain as last set.

**■ FADE PATTERNS**

In this mode you will only find soft fade patterns. Press the MODE button until the display shows "FPxx" whereas xx stands for numbers 00 until 07. The available patterns are defined as follow:

Pattern	Steps	Pattern	Steps
FP0	red-green	FP4	candy-lime
FP1	blue-green	FP5	candy-blue
FP2	blue-pink-red	FP6	candy-aqua-turquoise
FP3	yellow-lime-red	FP7	red-yellow-green-turquoise-blue-candy

Use the left/right arrows to change the pattern between any of the 8 presets, the display shows "FP0"... "FP07" accordingly and will remain to show unless the speed function is used. Use the +/- button to change the speed level. The first touch of the + or - button changes the display, now showing the speed level "SL00"... "SL25" representing the following speed levels:

Setting	Speed	Setting	Speed
SL0	1 loop per 960 seconds	SL13	1 loop per 3 seconds
SL1	1 loop per 480 seconds	SL14	1 loop per 2 seconds
SL2	1 loop per 360 seconds	SL15	1 loop per 1,5 seconds
SL3	1 loop per 240 seconds	SL16	1 loop per 1,25 seconds
SL4	1 loop per 120 seconds	SL17	1 loop per 1 second
SL5	1 loop per 80 seconds	SL18	1,2 loops per second
SL6	1 loop per 40 seconds	SL19	1,4 loops per second
SL7	1 loop per 20 seconds	SL20	1,6 loops per second
SL8	1 loop per 12 seconds	SL21	1,9 loops per second
SL9	1 loop per 10 seconds	SL22	2,2 loops per second
SL10	1 loop per 8 seconds	SL23	2,5 loops per second

Before you start to change the connectors, please make sure that:

- yourself or the person in charge has the relevant experience in safe work methods for electrical equipment service and maintenance.
- the unit is disconnected from any AC source. Please note that this also applies to the unit's AC output, since being connected by the AC output to other units which are still under AC supply, will still supply power to the unit.
- the unit is completely dry, and at room temperature.
- the location chosen to exchange the connectors does not have more than 40% relative humidity and the temperature during the exchange does not exceed 40 degrees Celsius. These parameters are important to avoid later condensation of the water contained in the environmental air when the unit works at lower outside temperatures.
- the screw driver used to dismantle and re-assemble the unit is properly matching the screws to avoid any damage to the screws. This will require a 4mm HexInsert screw driver.
- the screw driver has an in-built torque measurement or you have other torque-measurement devices on hand to make sure that screws are fastened with the right torque during re—assembly.

To expedite the connector change, you will need Multiform's outdoor conversion kit for this unit, which is available from your distributor. Further, you will also need to have the suitable cable material on hand, which ideally is

- Rubber AC cable of at least 3x1.5sqmm cross-section, with outer diameter of not less than 6mm, and not more than 9mm.
- DMX signal cable, 2-wire+shield, with outer diameter of not less than 6mm, and not more than 9mm.
- Matching wire termination sleeves.



**Reliability risk:** Using cable material of unsuitable outer diameter or with insufficient flexibility of its outer tubing may defeat the waterproof capabilities of the fixture and may void any warranty.

The conversion kit itself contains:

- The outdoor conversion panels (x2)
- The rubber seals for the outdoor conversion panels (x2)
- The PG9 cable glands made from stainless steel (x4)
- The Fitting screws to generate sufficient seal pressure (x4)
- The rubber plain washers as seals for the fitting screws (x4)
- The rubber dummy plugs needed if a cable gland remains without cable (x3)

To start expediting the connector change, please follow the below step-by-step instructions and draw your attention to the illustrations provided. Please note this refers to a conversion from indoor to outdoor; for the inverse conversion, please reverse the procedure's steps 5-16.

- 1) Loosen the 6pcs. of HexInsert screw that hold the rear cover of the power supply compartment, and remove the screws.
- 2) Carefully lift the rear cover with the attached electronics assembly from the main unit.
- 3) Turn the rear cover around, and unplug the wire connections to the main unit.
- 4) Detach the rear cover with the attached electronics assembly from the main unit.
- 5) Unscrew the fitted XLR and PowerCon connectors from the rear cover.
- 6) Unscrew the connector connection cables from the screw terminals on the MCU PCB (for DMX) and on the PSU PCB (for power).
- 7) Pre-assemble the PG9 cable gland body with the outdoor conversion panels. Make sure that the lower PG cable gland seal is fitted properly and that the nut which holds the gland in the outdoor conversion panel is tightened sufficiently. Do NOT yet fit the upper cover nut and the cable seals.
- 8) Turn the rear cover with the electronics assembly to face its outside. Mount the outdoor conversion panels with the pre-mounted PG gland bodies to the outside of the rear cover of the fixture, using the provided two mid-placed fixing screws.
- 9) Put the cover nuts of the PG glands over the cable end and push the cable seals on the cables.
- 10) Insert the cables into the cable gland bodies mounted to the rear cover and loosely fix the cover nuts, so that the cable can still be moved longitudinally.
- 11) Turn the rear cover with the electronics assembly to face its inside. Pull the cable stubs far enough out to allow skinning of the leads inside the cables.
- 12) Skin the separate leads of both the DMX and AC cables and terminate them properly with termination sleeves.
- 13) Insert the AC leads into the terminal block of the PSU PCB as indicated on the internal connections chart, and fix the terminal block screws accordingly.
- 14) Insert the DMX leads into the terminal blocks on the MCU PCB as indicated on the internal connections chart, and fix the terminal block screws accordingly.
- 15) Pull the cables from the outside of the rear cover until the remaining internal length is minimized without putting strain on the cables or their connections to the terminal blocks.
- 16) Turn the rear cover with the electronics assembly to face its outside. Tighten the cover nuts of the PG glands tight enough to make sure the rubber gland seal adapts properly and tightly to the cable's outer perimeter.
- 17) Connect the rear cover with the attached electronics assembly to the main unit by re-plugging the connections that have been unplugged in step 3.
- 18) Place the rear cover with the attached electronics assembly on the back side of the power supply compartment. NOTE: It is extremely important that the rubber seal - which is inserted in the groove of the outer edge of the power supply compartment - is properly fitted. Otherwise the unit may not be waterproof!
- 19) Insert the 6pcs. of HexInsert screw that hold the rear cover of the power supply compartment, and tighten them with 0.6~0.7Nm torque.

1 second accelerates the change rate of the displayed value to 3 times. If no further changes are made to the dimming level by the +/- buttons, the display will automatically return to show "C0"... "C225" after 5 seconds, and the dimming level will remain as last set. The same happens if the color is changed by the left/right arrows, in this case the dimming level mode is left immediately and the dimming level will remain as last set.

Note: This mode is intended to offer more color options than the static color mode. It however is not intended to offer more white shades, which means the white channel is not used in the color scroll mode.

**■ SWITCH / STROBE PATTERNS**

In this mode you will only find hard switching and strobe patterns. Press the MODE button until the display shows "SPxx" whereas xx stands for numbers 0 until 12. The available patterns are defined as follows:

Pattern	Steps	Pattern	Steps
SP0	red-green	SP7	red-green-blue
SP1	blue-green	SP8	yellow-green-turquoise-blue-candy-red
SP2	blue-red	SP9	Strobe red
SP3	yellow-red	SP10	Strobe green
SP4	candy-lime	SP11	Strobe blue
SP5	candy-blue	SP12	Strobe white
SP6	candy-turquoise		

Use the left/right arrows to change the pattern between any of the 13 presets, the display shows "SP0"... "SP12" accordingly and will remain to show unless the speed function is used. Use the +/- button to change the speed level or activate the Sound-to-Light function. The first touch of the + or - button changes the display, now showing the speed level "SL00"... "SL25" or "S2L" representing the following speed levels:

Setting	Speed	Setting	Speed
S2L	Sound-to-Light	SL13	1 step per second
SL1	1 step per 240 seconds	SL14	1,5 steps per second
SL2	1 step per 120 seconds	SL15	2 steps per second
SL3	1 step per 90 seconds	SL16	2,5 steps per second
SL4	1 step per 60 seconds	SL17	3 steps per second
SL5	1 step per 30 seconds	SL18	4 steps per second
SL6	1 step per 20 seconds	SL19	5 steps per second
SL7	1 step per 10 seconds	SL20	6 steps per second
SL8	1 step per 5 seconds	SL21	7 steps per second
SL9	1 step per 3 seconds	SL22	8 steps per second
SL10	1 step per 2 seconds	SL23	9 steps per second
SL11	1 step per 1,6 seconds	SL24	10 steps per second
SL12	1 step per 1,2 seconds	SL25	11 steps per second



Upon the user's choice, the unit can work in stand-alone automatic mode, or with fixed colors, or it may be controlled by external DMX-controllers. Available modes:

**■ STATIC COLOUR**

Press the MODE button until the display shows "STxx" whereas xx stands for numbers 0 until 25.

Use the left/right arrows to change the colour between any of the 26 presets, the display shows "ST0"... "ST25" accordingly and will remain to show unless the dim function is used. Use the +/- button to change the dim level. The first touch of the + or - button changes the display, now showing the dimming level "L000"... "L100" representing the relative dimming level chosen. Now the dimming level can be changed by using the +/- buttons. Pressing the +/- buttons for longer than 1 second accelerates the change rate of the displayed value to 3 times. If no further changes are made to the dimming level by the +/- buttons, the display will automatically return to show "STxx" after 5 seconds, and the dimming level will remain as last set. The same happens if the color preset is changed by the left/right arrows, in this case the dimming level mode is left immediately and the dimming level will remain as last set. Color settings for "ST0" ... "ST25" as follows:

Preset #	Color	Preset #	Color
ST0	all off	ST13	Peach
ST1	Red	ST14	Aqua
ST2	Green	ST15	Leaf
ST3	Blue	ST16	Purple
ST4	Yellow	ST17	Barbie
ST5	Pink	ST18	Breeze
ST6	Turquoise	ST19	White 1 (cold)
ST7	Lime	ST20	White 2
ST8	Orange	ST21	White 3
ST9	Marine	ST22	White 4
ST10	Frog	ST23	White 5 (warm)
ST11	Lavender	ST24	Light Orange
ST12	Candy	ST25	Dark Orange

**■ COLOUR SCROLL**

Press the MODE button until the display shows "Cxxx" whereas xxx stands for numbers 000 until 225. A touch of the left/right arrow buttons will lead to a change of the Colour. Choose your desired colour. The display shows "C0"... "C225" \* accordingly and will remain to show unless the dim function is used. Use the +/- button to change the dim level. The first touch of the + or - button changes the display, now showing the dimming level "L000"... "L100" representing the relative dimming level chosen. Now the dimming level can be changed by using the +/- buttons. Pressing the +/- buttons for longer than

**INDOOR/OUTDOOR CONVERSION**

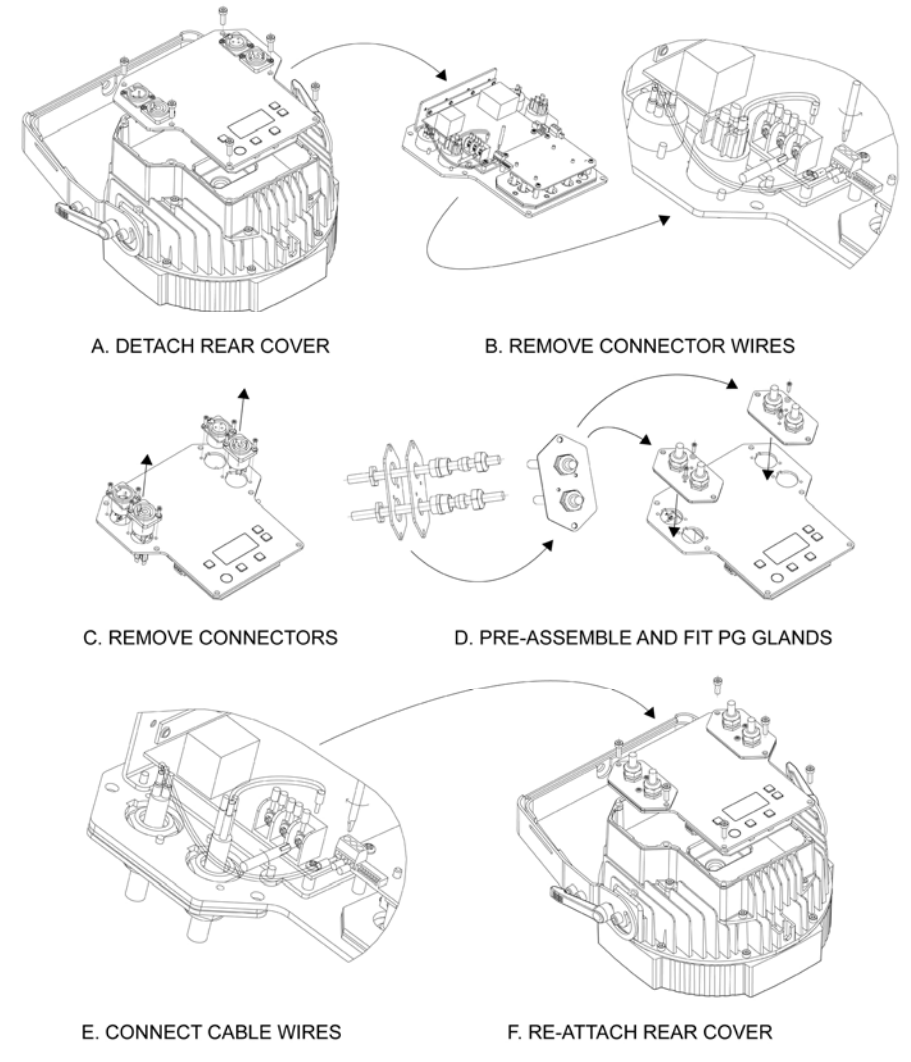

### INTERNAL CONNECTIONS (view from PCB side)

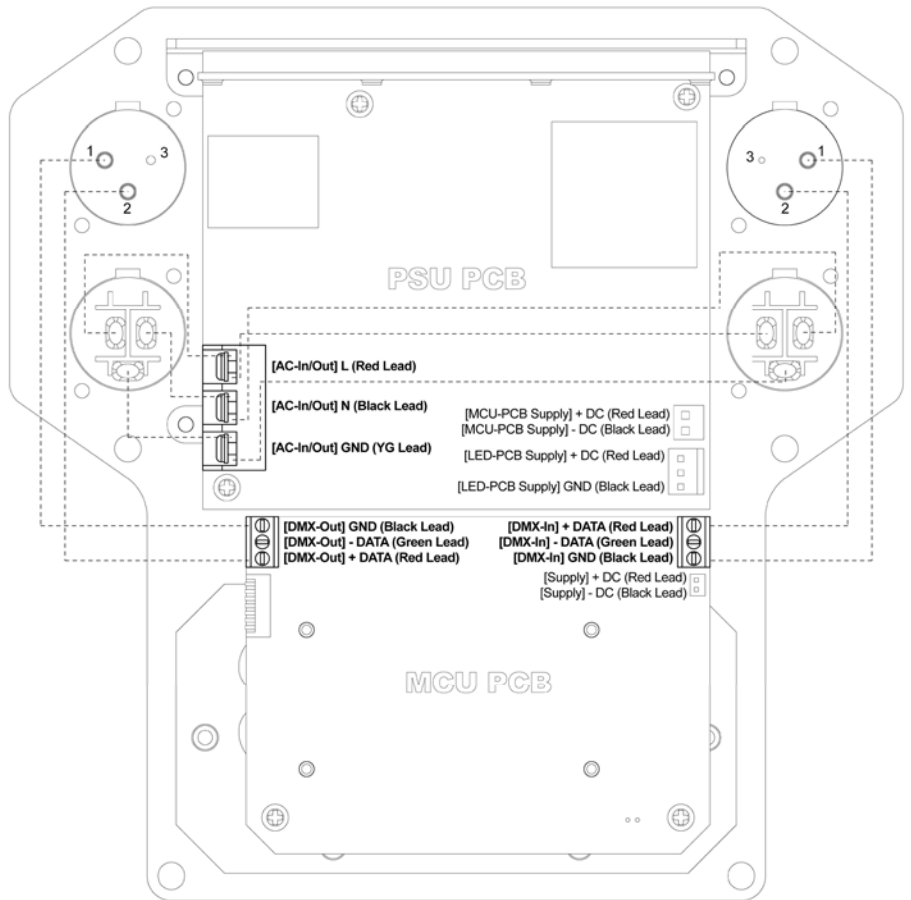

**DANGER!** Safety hazard.  
Risk of severe injury or death.

**WARNING!** Hazardous voltage.  
Risk of lethal or severe electric shock.

**NOTE:**  
Any internal work on this unit shall only be carried out by qualified technicians who are familiar with safe repair techniques. Disconnect AC before opening the unit.

### ■ Operation

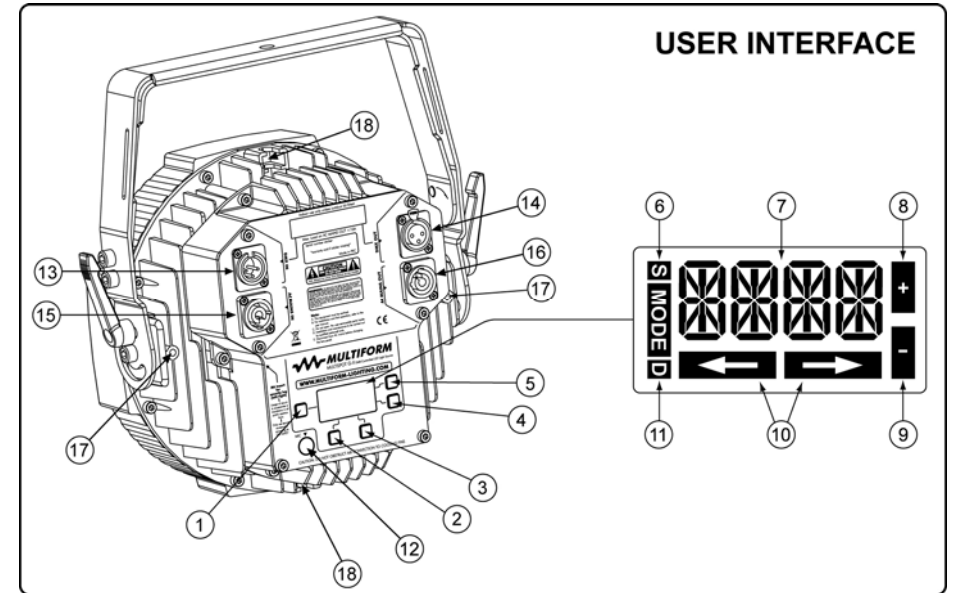

User interface overview:

- 1 MODE selection Button
- 2 LEFT ARROW Button
- 3 RIGHT ARROW Button
- 4 - Button
- 5 + Button
- 6 DISPLAY: Sound-to-Light Indicator
- 7 DISPLAY: 4-Digit Message Display Area
- 8 DISPLAY: + Indicator
- 9 DISPLAY: - Indicator
- 10 DISPLAY: ARROW Indicators
- 11 DISPLAY: DMX Signal Presence Indicator
- 12 Microphone cover membrane
- 13 DMX Input
- 14 DMX Output
- 15 AC Power Input
- 16 AC Power Output
- 17 M6 safety lug mounting thread
- 18 M10 nut insert point

weight of the device when installing the unit. This secondary safety attachment should be installed in a way that no part of the installation can drop more than 20cm if the main attachment fails.

- Never stand directly below the device when mounting, removing, or servicing the fixture. Make sure the area below the installation place is free from unwanted persons during rigging, de-rigging and servicing.
- The operator has to make sure that the safety-relating and machine-technical installations are approved by an expert before using them for the first time. The installations should be re-inspected every year.
- Make sure to comply with applicable cooling requirements if any.

■ Getting started: making AC supply connections



**Risk of fire / Safety risk**

- The MULTISPOT-GII-HS5034 LED requires an AC power source with sufficient power carriage and correct grounding to ensure safe operation. The AC power source must be equipped with a circuit breaker and earth leakage detector. Make sure to only use compliant AC supply lines.
- The MULTISPOT-GII-HS5034 LED has an AC outlet that is designed to carry loads of no more than 10A. Make sure that all connected devices in a chain fed by the first device do not exceed a maximum of 10A current consumption.

■ Getting started: making DMX control connections

Connect the MULTISPOT-GII-HS5034 to a suitable DMX controller where needed, and interconnect several units by means of their DMX In/Outputs as required. The last unit shall be fitted with a proper 120 Ohm termination resistor-equipped DMX-plug as shown in below drawing. Please make sure that all used DMX cables comply to below standard:

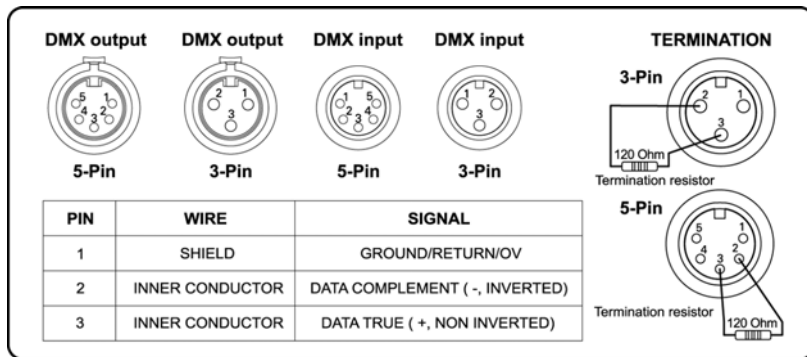

■ Getting started: changing the lens panel (only if required)

Your MULTISPOT-GII-HS5034 has been factory-fitted with the default lens panel. If you need to exchange the lens panel to achieve specific dispersion angles, please contact your distributor for availability information of other lens panels and follow the below procedure to exchange the lens panel if required.



**Reliability risk:** Exchanging the lens panel in an inappropriate manner may defeat the waterproof capabilities of the fixture and may void any warranty of the manufacturer if water intrudes into the unit. It is essential to follow the below instructions to maintain the waterproof capabilities of the fixture and its product warranty subsequently.

Before you start to exchange the lens panel, please make sure that:

- the unit is completely dry, and at room temperature.
- the location chosen to exchange the lens panel does not have more than 40% relative humidity and the temperature during the exchange does not exceed 40 degrees Celsius. These parameters are important to avoid later condensation of the water contained in the environmental air when the unit works at lower outside temperatures.
- The screw driver used to dismantle and re-assemble the unit is properly matching the screws to avoid any damage to the screws. This will require a 4mm HexInsert screw driver.
- The screw driver has an in-built torque measurement or you have other torque-measurement devices on hand to make sure that screws are fastened with the right torque during re-assembly.

To exchange the lens panel, follow the below procedure:

- 1) Make sure the unit is switched off and cooled down for at least 30 minutes after last operation. Detach all cables.
- 2) Lay the unit face-down on a stable but soft surface (like a table covered with a towel), and remove the 8 screws which connect the main fixture body with the front frame (Illustration step A).
- 3) Turn the unit around and lift off the front frame, while you hold down the front glass. Holding down the front glass is a safety precaution, since due to the adhesion of the soft rubber of the front glass seal, it could potentially happen that the front glass including its rubber seal “stick” to the front frame and fall out during the removal procedure, potentially damaging the front glass.
- 4) Carefully lift off the front glass including the glass seal (Illustration step B).
- 5) Unscrew and remove the 5 lens panel screws holding the lens panel.
- 6) Remove the lens panel by vertical lifting it off. It is important to expedite this process absolutely perpendicular to the LED panel, as excessive tilting of the lens panel versus the LED panel can damage the LEDs. Use both hands and the provided finger grip points and lift off the lens panel.

- 7) Remove the 5 standoffs that define the lens panel distance to the PCB by unscrewing them with left-turns. Keep these 5 standoffs stored together with the removed lens panel as every specific lens panel has its matching standoff length.
- 8) Insert the 5 standoffs that have been delivered with the new lens panel into the relative thread holes and fix them properly with right-turns.
- 9) Put the new lens panel into place by perpendicularly lowering it down on the LED panel. Make sure the LED panel is lowered in the right position, as lowering it in the wrong position may lead to collision between the lenses and the LEDs, which may damage the LEDs.
- 10) Put the 5 lens panel screws back into place which hold the lens panel and tighten them with 0.50-0.55Nm torque.
- 11) Check whether the front glass seal smoothly surrounds the front glass in proper position and put the front glass back into place, properly centering it on the mounting edge around the Lens/LED panel.
- 12) Check whether the main seal is properly aligned and smoothly adapts to the groove around the lens/LED panel.
- 13) Carefully lower the front frame down on the main unit in the right position with aligned screw holes, avoiding any position change of the front glass with seal and the main seal during this procedure.
- 14) Provide clamping of the main unit and the front frame by means of holding them together with both hands, and turn the unit around.
- 15) Put the 8 screws back into place which connect the main unit with the front frame and tighten them with 3.0-3.3Nm torque.
- 16)

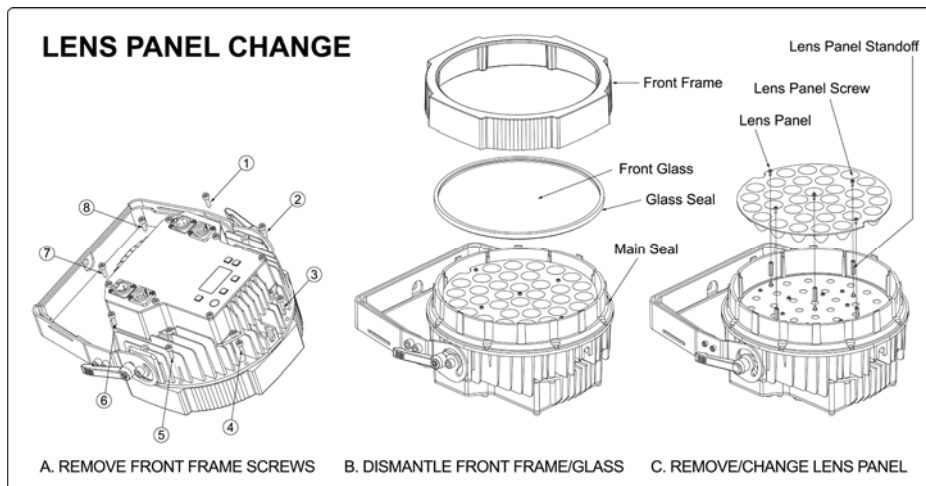

### ■ Getting started: choosing a location



**Risk of fire:** The MULTISPOT-GII-HS5034 LED has been designed for environmental temperatures of up to 40 degrees Celsius. For proper operation, the unit must be operated with unobstructed air convection to its outside metal case.

### Do not:

- Operate the MULTISPOT-GII-HS5034 LED in environments with more than 40 degrees environmental temperature
- Operate the MULTISPOT-GII-HS5034 LED in any closed environment smaller than 10cbm, unless forced air convection is provided.

### ■ Getting started: secure mounting

The MULTISPOT-GII-HS5034 LED can be mounted in various ways:

#### Floor standing operation

- Turn the bracket to the lower side of the unit and fold out the second, inlaying bracket.
- Place the unit in a secure position where it can neither be touched by anyone or could possibly become an objective for anyone to stumble.
- Make sure to comply with cooling requirements of the used power supply if any.

#### Hanging/Rigging, ceiling-mounted operation



**Risk of injury:** Overhead mounting requires extensive experience, like calculating working load limits, knowledge installation materials, and periodic safety inspection of all installation material and the unit. If you lack such qualifications, do not attempt the installation yourself. Improper installation can result in body injury. Be sure to complete all rigging and installation procedures before applying power to the unit.

- Leave the inner and outer bracket folded.
- The unit should be installed out of reach of people and outside areas where persons may walk by or be seated.
- Make sure that the installation area can hold a minimum point load of 10 times the device's weight.
- In fixed installations, fix the unit with self-locking screws/nuts to the mounting point.
- When mounting the unit to truss be sure to secure an appropriately rated clamp to the hanging yoke using a M10 screw fitted through the center hole of the hanging yoke.
- Where required, secure the installation with an appropriate safety cable. Always use a certified safety cable according to DIN56927 that can hold 12 times the