

Welcome

Thank you for choosing Hill Audio for your sound system. To make sure that this product meets your expectations and provides long-term, reliable performance, please read and follow this instruction manual carefully.

Manual Language

UK	This user manual is written in English. For other languages, visit	www.hill-audio.com
FR	Ce guide est écrit en anglais. Pour les autres langues, visitez:	www.hill-audio.com
DE	Diese Anleitung ist in Englisch verfasst. Für andere Sprachen:	www.hill-audio.com
ES	Este manual está escrito en Inglés. Para otros idiomas, visite:	www.hill-audio.com
PT	Este manual está escrito em Inglês. Para outros idiomas, visite:	www.hill-audio.com
IT	Questo manuale è scritto in inglese. Per altre lingue, visitare:	www.hill-audio.com

Important safety instructions

- Read these instructions and all markings on the product. Keep these instructions.
- Heed all warnings and instructions, both in this manual and on the product.
- Clean only with a dry cloth. Unplug from AC supply before cleaning.
- Do not use this product near water and avoid any exposure to water.
- Before connecting this product to any AC supply, make sure you check whether the AC mains voltage and frequency match the indication on the product and its packaging.
- Only connect this product to an AC supply with sufficient power handling, protective earth connection, ground-fault (earth-fault) protection and overload protection.
- Disconnect the product from the AC supply during thunderstorms. Also disconnect from the mains supply if the product is not being used for long periods.
- Make sure any heat sink or other cooling surface, or any air convection slot, is exposed sufficiently to free air circulation and is not blocked.
- Do not operate this product in environmental temperatures exceeding 35 degrees Celsius and/or 85% relative humidity.
- Position the product in a safe and stable place for operation, out of reach of unauthorized persons.
- Make sure any cable connections to and from the product are neither subject to potentially destructive mechanical impact nor present any risk of stumbling or other accident risk to people.
- Audio equipment may generate sound pressure levels sufficient to cause permanent hearing damage to persons. Always start up at low volume settings and avoid prolonged exposure to sound pressure levels exceeding 90 dB.
- Do not open this product for service purposes. There are no user-serviceable parts inside. Warranty will be void in any case of unauthorized service by the user or other unauthorized persons.
- Take any precaution required by local law, applicable regulations or good business practice to avoid injury to people or material damage by use of this product.

Explanation of symbols used in this manual and on the product:



ATTENTION!
Read manual before installation and operation.



DANGER!
Safety hazard.
Risk of injury or death.



WARNING!
Hazardous voltage.
Risk of severe or fatal electric shock.



WARNING!
Fire hazard.

Description

The IMM2320 is a combination of a basic audio mixer for stereo music sources and two microphones with a media player including FM tuner and IR remote control. It perfectly serves applications where foreground or background music is mixed with vocal announcements, as it frequently occurs in fitness and hospitality applications. Specifically in fitness music applications, the IR remote control and the automatic music level reduction when the microphone is spoken into, greatly facilitate efficient instructor work. Adding external music mute and emergency signal priority inputs, the IMM2320 integrates seamlessly with the fire evacuation requirements of publicly used venues.

Health advice

This unit produces and absorbs electromagnetic radiation. The strength of radiation and the sensitivity for disturbing interference matches the CE and FCC requirements. A corresponding sign is printed on the backside of the unit. Any change or modification may affect the behavior of the unit concerning electromagnetic radiation and it may not then meet CE requirements. The manufacturer takes no responsibility in this case.

Functional advice

This unit is immune to the presence of electromagnetic disturbances – both conducted and radiated - up to a certain level. Under peak conditions, the unit is classified to show a “class C” performance criteria and may encounter temporary degradation or loss of function which may need manual help to recover. In such case, disconnect the AC power from the unit and reconnect it again to recover.

Environmental advice

This unit is built to conform to the ROHS standards and the WEEE directive 2002/96/EC of the European Parliament and of the Council of the European Union. Under these regulations, the product shall not be discarded into regular garbage at the end of its life, but shall be returned to authorized recycling stations.

Unpacking

Please check that the box contains the following items:

Main parts: 1 pc. IMM2320 main unit
 1 pc. Mains cable
 1 pc. FM antenna adapter
 1 pc. IR remote control
 1 pc. Operation manual

If any part is missing, please contact your dealer immediately.

Warning



After unpacking, and before plugging the AC cord in the wall outlet, check whether the AC mains voltage and frequency is compatible with this product (see rear panel of product). Whenever the specified voltage or your AC plug should not match the local conditions, do NOT plug the AC cord into the wall outlet and contact your dealer in order to change the AC supply voltage settings pursuant below instructions.

Maintenance and warranty

While we have chosen the best components to make this product as rugged and reliable as possible, some parts in audio products (potentiometers, faders, switches) are subject to wear which is a matter of operation cycles, and not of time. While providing a full time-based warranty according to the country's of purchase requirements on the function of the electronic circuitry, we hence have to limit the warranty on such electro-mechanical parts to 90 days from the date of purchase.

Kindly note that any warranty is void if the unit has been modified or attempted to be repaired by inappropriate means or a non-qualified service center.

AC mains voltage setting



WARNING - RISK OF FIRE

Changing the AC supply voltage setting can result in a fire hazard if the settings are made incorrectly. Any change of AC supply voltage setting shall be expedited only by qualified, certified personnel.

If the AC mains voltage of your power outlet and the setting of the AC supply voltage on your unit do not match, contact your dealer, contractor or a qualified service workshop to change the setting of the AC voltage selector. The AC voltage selector switch is located on the side panel of the unit, close to the AC inlet.

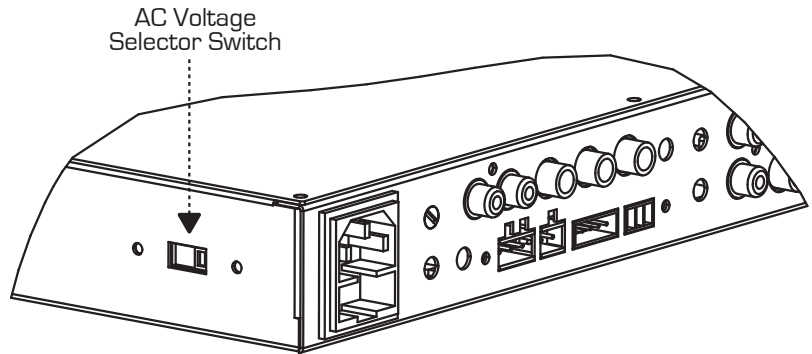

Internal Settings



WARNING - DANGER

Changing the internal settings requires to open the unit. Prior to opening the unit, the unit shall be disconnected from any AC supply. Any work on an open unit shall be expedited only by qualified, certified personnel.

Microphone emergency setting

In the case of an external emergency signal muting the unit's outputs, an internal jumper can be set to either mute the connected microphones ("off") as well or to keep them active (so that aside of a emergency message broadcasted, additional instructions can be given by a local microphone - "on"). To make the setting, locate and set the jumper on the front PCB as shown below.

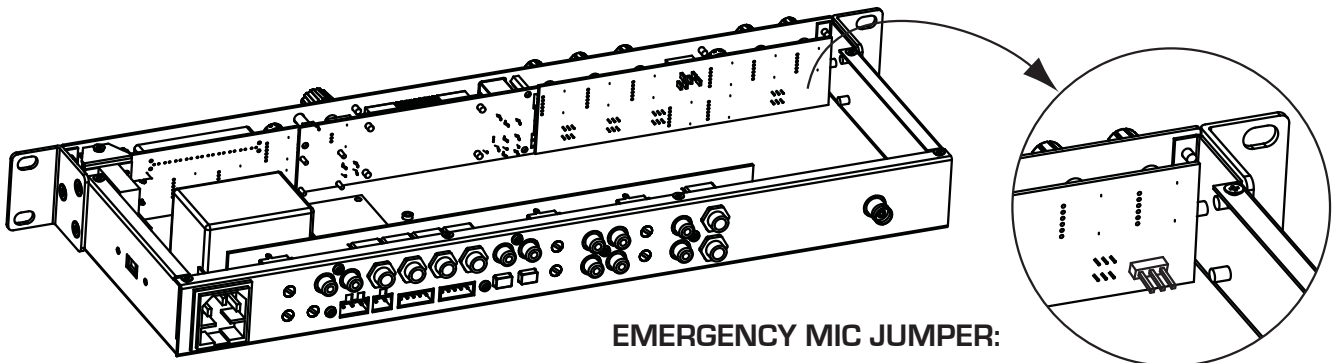

EMERGENCY MIC JUMPER:

- OFF (DEFAULT)
- ON

Controls and Connections

Rear: Output Section

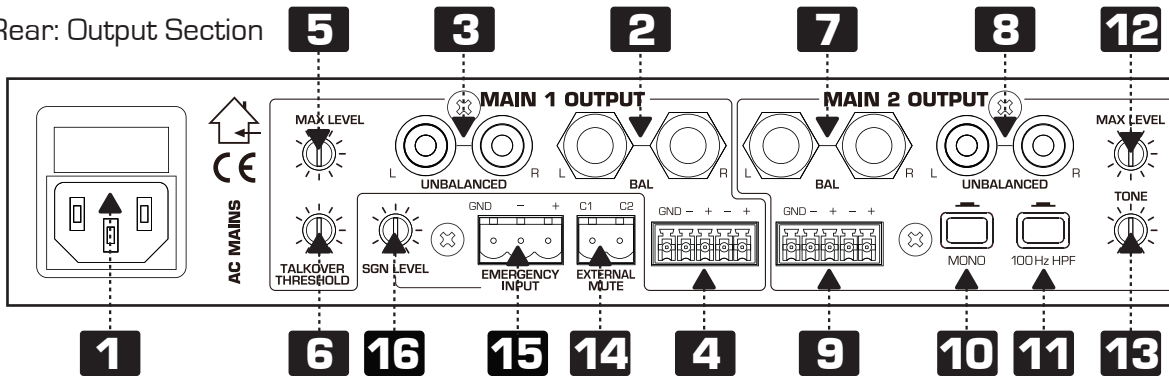

Rear: Input & Record Section

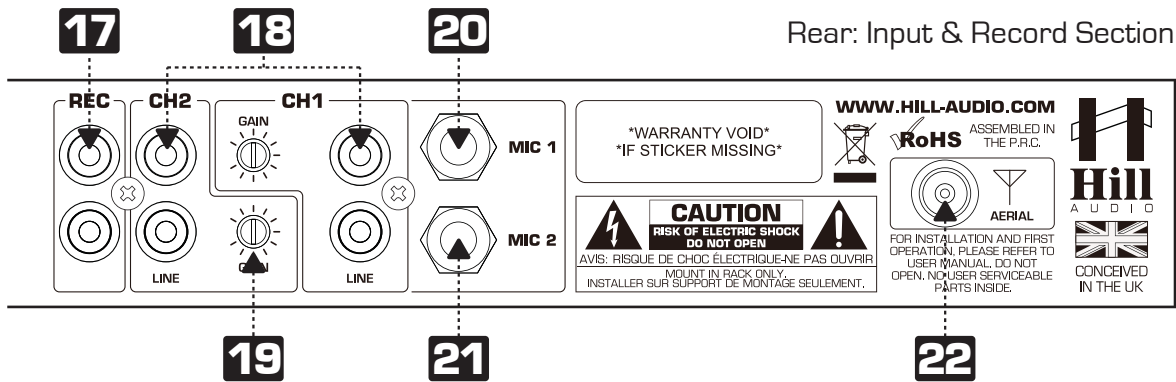

Front: Input Section

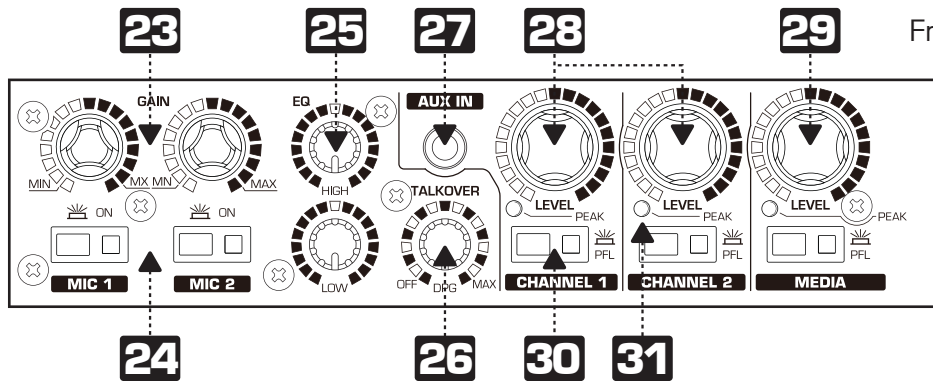

Front: Output Section

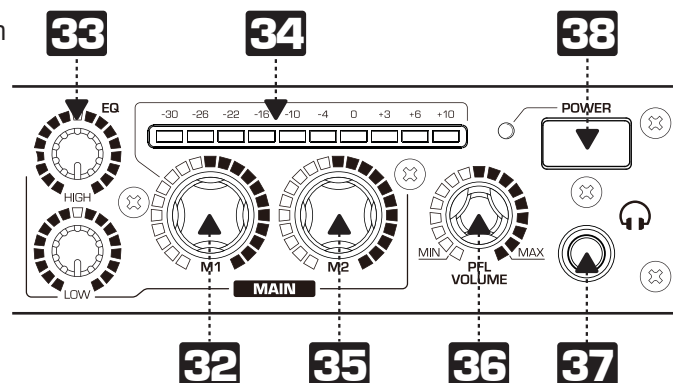

Controls - Front (Media Player | Tuner)

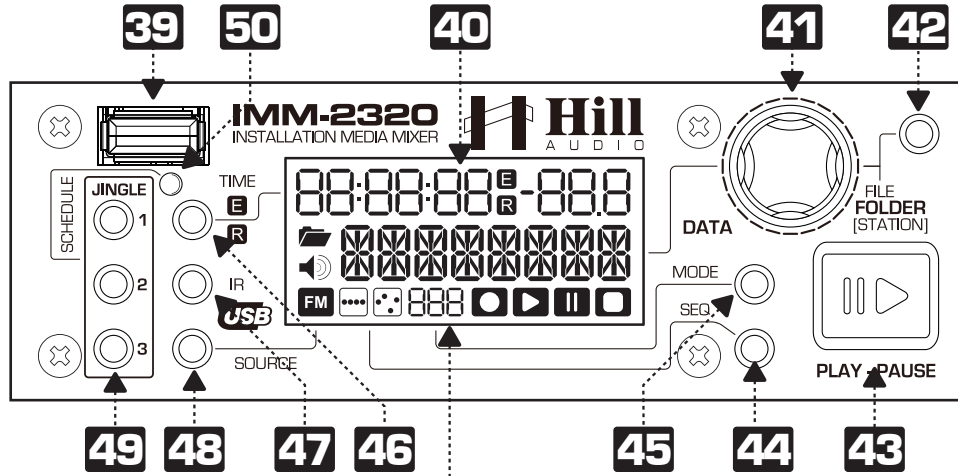

Display - Elements

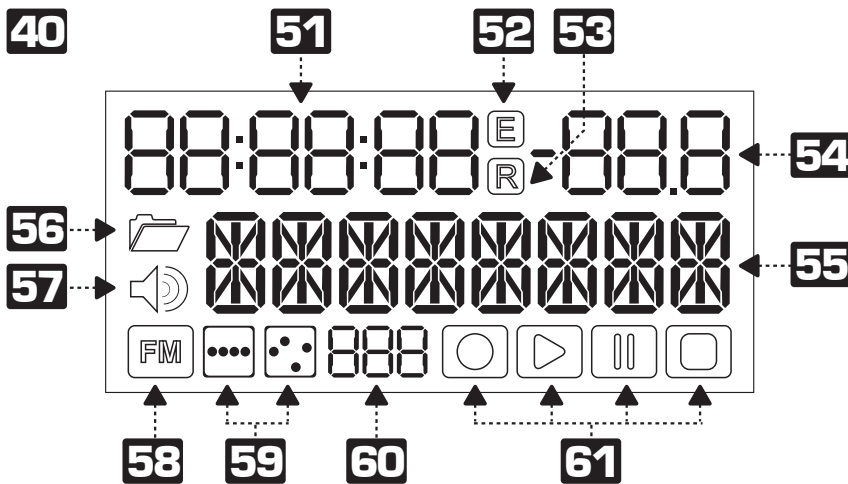

Remote Control - Elements

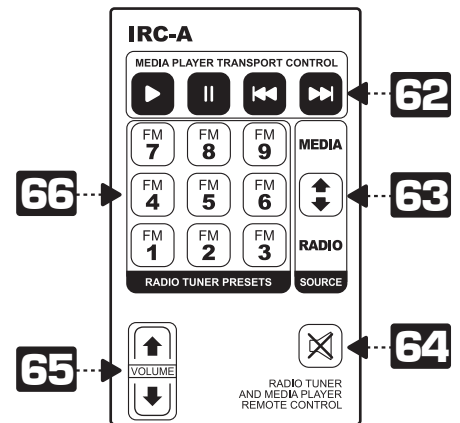

Functional Description

The IMM2320 is a combination of a compact audio mixer with two microphone inputs and three stereo sources and a media player with FM tuner and jingle player. Packed in a sleek 19"1U case and fitted with an infrared remote control for the media player functions, this unit is a perfect centre piece for commercial sound systems in hospitality and fitness audio applications.

- 1** AC inlet and fuse holder. Use the supplied AC cord to connect the unit to AC mains. Make sure voltage and frequency stated and set on the unit comply with your local AC supply. The fuse can be accessed by the small drawer at the AC inlet. To change the fuse, unplug the AC cord first, pull out the fuse drawer and replace the fuse ONLY with a fuse of SAME voltage and rating. If the fuse blows again after replacement, hand over the unit to qualified service personnel.
- 2** First stereo main output. This is a balanced stereo ¼" TRS output carrying the main output signal controlled by [32].
- 3** First stereo main output. This is an unbalanced RCA output carrying the same signal as output [2].

- 4** First stereo main output. This is a balanced terminal block output carrying the same signal as output (2)
- 5** Maximum level setting for first stereo main output. This control allows to limit the maximum level at the outputs (2)/(3)/(4) in order to match the connected sound system. Adjustments made on this control will not be displayed by the output level meter (34). Adjustments shall be made with a small screw driver. Note that the total angle is 300 degrees; do not apply excessive force with the screw driver.
- 6** Talkover adjustment. This control allows to set the level at which the talkover is enabled. The amount of damping which is applied once the talkover is active (DPG) is set by a front panel control (26). Adjustments shall be made with a small screw driver. Note that the total angle is 300 degrees; do not apply excessive force with the screw driver.
- 7** Second stereo main output. This is a balanced stereo ¼" TRS output carrying the main output signal controlled by (35).
- 8** Second stereo main output. This is an unbalanced RCA output carrying the same signal as output (7).
- 9** Second stereo main output. This is a balanced terminal block output carrying the same signal as output (7)
- 10** Mono switch for second stereo main output. Allows to sum the two stereo signal (L&R) to one mono signal, which is present at both the L&R outputs of connectors 7, 8 and 9.
- 11** High Pass Filter (100Hz) for second stereo main output. Pressing this switch will engage a 100Hz HighPass filter, thus removing low frequencies from the second stereo main output signal. This can be useful if the second stereo main output feeds a system with limited low frequency response, like small-size background music speakers or ceiling speakers.
- 12** Maximum level setting for second stereo main output. This control allows to limit the maximum level at the outputs (7)/(8)/(9) in order to match the connected sound system. Adjustments shall be made with a small screw driver. Note that the total angle is 300 degrees; do not apply excessive force with the screw driver.
- 13** Tone control for second stereo main output. This control shifts the frequency response from a "darker" to "brighter" characteristic to adapt to the connected speaker system. Adjustments shall be made with a small screw driver. Note that the total angle is 300 degrees; do not apply excessive force with the screw driver.
- 14** Music Mute input. This is a terminal block input which allows to remotely mute all output signals (first & second stereo main outputs) by simply shortening the contacts.
- 15** Emergency input. This is an auto-sensing, balanced terminal block input which allows the connection to an emergency evacuation system. Once a signal is present on this input, all output signals (first & second stereo main outputs) will be muted and the emergency message/signal from this input will become audible instead. Please note that the unit can be set to include or exclude the microphone signals from this muting process, please see section "microphone emergency setting".
- 16** Emergency volume control. This control allows to set the level with which the signal fed into the emergency input (15) will be replayed at the two master outputs (2)/(3)/(4) and (7)/(8)/(9).

- 17** Record output. This is an unbalanced stereo output carrying the same signal as the main output, but not influenced by the main volume controls (32, 35). This is normally used for recording the output to an external tape, CD or memory device.
- 18** Music channel 1 & 2 inputs. These RCA connectors provide inputs for line-level signals to the assigned channels. The input sensitivity can be adjusted by means of the controls (19).
- 19** Gain control for music input channels (18). This allows the sensitivity (input gain) for every line input to be adjusted, so that sources of different output level can be mixed at properly balanced levels.
- 20** Microphone input for MIC1. This is a balanced ¼" TRS connector, without phantom power provision, hence only suitable for dynamic microphones.
- 21** Microphone input for MIC2. This is a balanced ¼" TRS connector, without phantom power provision, hence only suitable for dynamic microphones.
- 22** Aerial socket. Plug in a suitable FM antenna here, or connect any suitable antenna cable of the house installation here (75 Ohms cable). Depending on whether the antenna connector is male or female, the included adaptor may be required.
- 23** Level controls for microphone inputs. Allow the individual adjustments of the levels for MIC1 and MIC2, which relate to the rear side inputs (20) and (21) accordingly.
- 24** Microphone ON/OFF switches for MIC1 and MIC2. Enables/Disables the MIC1 and MIC2 signals respectively.
- 25** Microphone Equalizer. Allows the adjustment of the tonal balance for the microphone inputs in two voice-specific frequency bands with an adjustment range of ±12dB. Please note the setting will affect both microphone inputs simultaneously.
- 26** Talkover Damping Control. This control determines the amount of damping applied to the program signal when a microphone is spoken into. Being fully turned clockwise, once speaking into the microphone, the program signal is completely suppressed. Being turned fully counter-clockwise, the talkover function is off. Any position in between allows seamless adjustment of the amount of damping applied to the program signal. The threshold level from which on this function is enabled can be set by the rear panel sensitivity level control (6).
- 27** AUX Input for music channel 1. This is a 3.5mm Mini-TRS stereo socket which allows to connect sources like MP3 players etc. without removing the this unit from its mounting position. Once a plug is inserted, the rear panel inputs for music channel 1 are disabled and the connected source is active.
- 28** Level control of music channel 1 & 2. Allows adjustment of the respective channel level.
- 29** Level control of media player/tuner. Allows the level adjustment of the internal sources.
- 30** PFL switch for input channels. Assigns the respective channel to the headphone bus for pre-fader-listening (PFL) by means of the headphone output (37). A LED indicates the pressed position.
- 31** Peak LED. This LED will illuminate when an input signal with more than 0dB of signal level is present. This facilitates to set the rear-panel gain controls (19) correctly for proper gain balance.

- 32** First stereo main output volume control. Allows to set the overall level of the first stereo main output [2]/[3]/[4], while the level balance of the individual sources can be adjusted via controls [23], [28] and [29].
- 33** First stereo main output equalizer. Allows the adjustment of the tonal balance for the first stereo main output signal in two music-specific frequency bands with an adjustment range of ± 12 dB. The second stereo main output signal is unaffected by these controls.
- 34** First stereo main output level meter. Displays the output level of the first stereo main output [2]/[3]/[4]. Note that the level limitation applied by means of the rear-side maximum level control [5] is not displayed on this meter.
- 35** Second stereo main output volume control. Allows to set the overall level of the second stereo main output [7]/[8]/[9], while the level balance of the individual sources can be adjusted via controls [23], [28] and [29].
- 36** PFL level. Determines the signal volume at the headphone output [37]. Always set this control to minimum before putting on headphones, as sudden high-volume impact may damage your ears. See further health advice below. The signal itself consists of the input signals assigned via switches [3] to the PFL output, irrespective of the relative signal being present on the main stereo outputs. This allows to prelisten an input signal while a different signal plays through the outputs.
- 37** Headphones output. A 1/4" TRS connector to connect a headphone. Turn the PFL level [36] down before plugging in any headphones.
- 38** Power switch. Switches the unit on and off. Make sure you switch the unit off when not in use.
- 39** USB memory socket. Insert a FAT32-formatted USB memory stick of max 16GB with a one-level folder structure for replay of MP3 files here. Note that this socket does NOT support USB hard drives, neither for memory size nor for power requirements.
- 40** Media player display. Shows track/folder information, time information, play status, replay mode settings and play sequence settings. Details are described under items [51...61]
- 41** Data dial. Depending on the chosen source (FM or Media - via control 48), this control has different functionality:
In Media Play mode [Indicator 58 off] | Turn: choose a song/folder, Press: activate the choice.
In FM Mode: [Indicator 58 on] Press: choose between frequency scroll or station preset scroll, Turn: choose frequency or station. The choice is immediately active.
- 42** Folder level [Store] button. Depending on the chosen source (FM or Media - via control 48), this control has different functionality:
In Media Play mode [Indicator 58 off] | Press: go to folder level, then navigate by data dial [41]
In FM Mode: [Indicator 58 on] | Allows you to store a new station preset. Choose frequency scroll mode by pressing [41] if required. Press the Folder Level [Store] button [42] once to display the station preset you wish to store the frequency at. Choose the preset by turning [41] and confirm by pressing the Folder level [Store] button [42] again, the station is now stored at the chosen preset.
- 43** Media PLAY/PAUSE/STOP button. Press briefly to toggle between PLAY (backlight continuously lit) and PAUSE (backlight flashing) mode. Press for longer than 2 seconds to change into STOP status (backlight off). Restart by pressing the button again, this will commence replay from the last known position when having been in PAUSE mode or from the start of the chosen track when being in STOP mode. This control is inactive in FM mode. The selected status is displayed in the display [61]

- 44** Play sequence selector (this control is inactive in FM mode). Selects between:
Straight play sequence: The next song is determined by alphanumerical sorting. The left sequence mode indicator is lit in the display (59).
Random play sequence: The next song is determined by random choice. The right sequence mode indicator is lit in the display (59).
- 45** Play mode selector. Selects between
SPL = Single Play. The player stops after playing the current song once. The next song is manually chosen by (41) and determined by the chosen play sequence.
SLO = Single Loop. The player loops the current song endlessly. The next song is manually chosen by (41) and is determined by the chosen play sequence.
ACO = All Continuous. The player continues after the playing the current song. The next song is determined by the chosen sequence. The player stops after the sequence is executed once.
ALO = All Loop. The player continues after the playing the current song. The next song is determined by the chosen sequence. The player repeats the sequence endlessly.
Those chosen play mode is displayed in the display (60). This control is inactive in FM mode.
- 46** Time Display selector. Selects between elapsed/remaining time display. The time display choice is shown in the display (52) and is always related to track currently playing. This control is inactive in FM mode.
- 47** IR Receiver sensor. If using the included IR remote control, make sure an unobstructed line of sight is available between the remote control and the IR receiver sensor.
- 48** SOURCE button. Toggles the program source between Media play and FM Tuner. If FM Tuner is chosen as the program source, the display's FM Mode indicator (58) is lit while the media replay related indicators (59/60/61) are disabled. Further the media replay related user interface elements (44/45/46) are disabled and the functional assignment of the navigation controls (41/42) is changed.
- 49** JINGLE buttons. Provided that the inserted media contains a folder named "Jingles" in its root directory, and that the files in this folder follow certain naming conventions, up to 3 of these files can be activated by the buttons (49). When a jingle is activated, the current program is muted and the jingle is played instead; however, the program progresses in the background. Jingles can be played both in Media play mode and FM mode. A further scheduled jingle play mode is available by pressing the J1 (jingle 1) button for longer than 2 seconds, the LED (50) will indicate that the scheduled jingle play mode is active. To de-activate the scheduled jingle play mode, press the J1 button again for more than 2 seconds. For more details, please see the "Jingle player" chapter.
- 50** Scheduled Jingle Play Mode Indicator. This LED is lit when the scheduled jingle play mode has been activated by pressing the J1 button for longer then 2 seconds

Display Elements

- 51** Time Display. Depending on the chosen source (FM or Media - via control 48), this part of the display shows different content:
In Media Play mode (Indicator 58 off): Either the remaining or elapsed time are displayed in a hh:mm:ss format, depending on the setting made by (46).
In FM Mode: (Indicator 58 on): If the unit works in station scroll mode, the currently chosen station preset number is displayed. If the unit works in frequency scroll mode, this part of the display remains unused (blank).
- 52** Time Mode Display (Elapsed): In Media play mode, this part of the display indicates that the elapsed time of the current track is shown in the time display (51). The setting can be altered by (46). This part of the display remains unused in FM mode.

- 53** Time Mode Display (Remaining): In Media play mode, this part of the display indicates that the remaining time of the current track is shown in the time display (51). The setting can be altered by (46). This part of the display remains unused in FM mode.
- 54** Numeric data display. This part of the display is not used in this product. This is NOT a malfunction.
- 55** 8-Digit Clear Text Readout. Depending on the chosen source (FM or Media - via control 48), this part of the display shows different content:
In Media Play mode (Indicator 58 off): The file name of the currently playing track is shown, with its first 30 digits scrolling through the display. Letters exceeding 30 digits will be discarded. Note that this is NOT an ID3 tag readout, but a file name readout, so files must be named properly to yield a sensible displayed content. The display will show the file name and alternate with the folder name the current file is located in. Whether at a specific time the file or the folder name is displayed, is indicated by the respective symbols (56/57)
In FM Mode: (Indicator 58 on): The RDS station name (PS section of the RDS signal) is displayed if the received FM signal contains this information. If no RDS station name is available, the currently tuned frequency is displayed. Note that this unit only displays the station name of the RDS signal, no other potentially contained RDS content.
- 56** Folder Name Display Indicator. In Media play mode, this indicator shows that the current content of the Clear text readout (55) is a folder name. This indicator is not used in FM mode.
- 57** File Name Display Indicator. In Media play mode, this indicator shows the current content of the Clear text readout (55) is a file name. This indicator is not used in FM mode.
- 58** Source Mode Indicator. Shows whether unit is in Media play mode (indicator off) or FM mode (indicator on). The mode can be changed via the control (48).
- 59** Play Sequence Indicator. In Media play mode, this indicator shows whether the unit is set to straight sequential or random play sequence. The setting can be altered by control (44). This indicator is not used in FM mode.
- 60** Play Mode Indicator. Based on the selection made by control (45), this part of the display shows the letters "SPL", "SLO", "ACO" or "ALO". This indicator is not used in FM mode.
- 61** Transport status indicators. In Media play mode, 3 standard symbols indicate whether the unit is in PLAY, PAUSE or STOP status. The 1st (outmost left) indicator is not used in this product; this is NOT a malfunction.

Remote Control Elements

This unit includes an IR (infrared) remote control. For proper operation, a line of sight between the remote control and the sensor on the unit (47) is required. The IR remote does only control the basic functions of the media player section and as such adds convenience to the operation, but does not replace the front panel control on the unit itself.

- 62** Transport Controls. In Media play mode, the 4 transport control buttons allow you to start and pause a track, and further skip to the next track or back to the beginning of the current track. These controls are inactive in FM mode.
- 63** Source button. Toggles the program source between Media play and FM Tuner. If FM Tuner is chosen as the program source, the display's FM Mode indicator (58) is lit while the media replay related indicators (59/60/61) are disabled. Further, the media replay related user interface elements (44/45/46) are disabled and the functional assignment of the navigation controls (41/42) is changed.

- 64** Mute button. Toggles between muted and un-muted output of the media player.
- 65** Volume control (up/down). Allows you to set the required audio volume of the media player.
- 66** FM preset station buttons. Allows to remotely activate the stored FM station presets. These buttons only work in FM mode and are disabled in Media play mode. Note that manual tuning via the IR remote control is not possible.

Notes on files, folders and data conventions

The media player section build into this unit is a hardware player and as such subject to various restrictions, which are useful to be aware of:

- **Media Memory types.** The player only works with SD cards and USB sticks up to 16GB of size which are formatted in FAT32 file system and contain a maximum of 2000 files. The player does NOT support larger memory sizes, external hard disks or any media with NTFS formatting.
- **Media File types.** The player's replay ability from solid state memory media is limited to MP3 files in MPEG 1 Layer 3, MPEG 2 Layer 3, MPEG 2.5 Layer 3 standard, with sample rates of 128/160/192/224/256/320 kbps + VBR. Any other files existing on the solid state memory media will be ignored and are not available for replay.
- **File/Folder Structure.** The player only allows a two-layer folder structure on the solid state media memory, meaning a root layer and a folder layer, but not any cascaded folder-in-folder structures. Such subfolders will be ignored and their content is not available for replay. Playable files located in the root layer are displayed in a folder named "ROOT" although this folder does not physically exist on the solid state memory media.
- **Folder Sorting.** Folders are displayed in the sequence of their creation dates on the solid state memory media. If a specific sequence is needed, then the folder shall be created in this sequence on the memory media before copying any MP3 files into them.
- **File Sorting.** Files are sorted alphanumerically, but due to file system limitations, the sorting is limited to the first 8 digits. This may in some cases - where the first 8 digits are identical - lead to a random-looking, not alphabetical sorting sequence of files.
- **File system cache.** In order to allow relatively quick access to the file directory during navigation, the player loads a copy of the file directory into its own memory upon insertion of the solid state memory media. This loading process requires some time, during which the display shows a count-down. The time required is about 4 seconds per 100 tracks with a maximum of 2000 tracks [meaning Max. 80 seconds loading time].
- **Displayed File/Folder names.** MP3 files are displayed with the first 30 digits of their file names in a scrolling manner; digits exceeding the first 30 will be ignored. Note that the display data is the file name and NOT the ID3 tag of the file. Folders are displayed with the first 10 digits of their names, any exceeding digits will be ignored.

Jingle Player

This unit contains a Jingle player with a one-shot mode for teasers and a scheduled mode for commercial purposes (like playing advertisements in a certain sequence). To make use of the feature, the user must create a folder named "Jingles" on the solid state memory media. The folder must have exactly this name (with capital J and lower case following letters) and will not be available for choice during normal replay.

The jingle files stored in this folder have to be prepared with specific names as well, and have to follow the structure jx_yy with x from 1...3 and yy from 00 to 99. In this format, x defines the jingle number (with a maximum of 3 jingles allowed) and yy being the number of minutes of background music the jingle is followed by in scheduled jingle play mode. As an example, three jingles could be named j1_01.mp3, j2_04.mp3 and j3_05.mp3. These three jingles will then be available for direct one-shot play on pressing the jingle buttons [49], with each jingle assigned to the relative button.

A scheduled jingle play mode can be activated by pressing the J1 button for longer than 2 seconds, allowing the jingles to be inserted into the program in an automatic sequence with a certain duration of background music in between. The jingle replay would in the above example start immediately with Jingle 1 followed by 1 minute of background music, then Jingle 2 followed by 4 minutes of background music, then jingle 3 followed by 5 minutes of background music; after this, the sequence would loop. If less jingles are stored in the Jingles folder, the loop runs after the last available jingle. As another example, if only one jingle named j1_02 is stored in the Jingles folder, then this would mean the jingle would play every 2 minutes in scheduled jingle pay mode.

Operation

A. Connections

For connecting this unit to AC mains, please follow the instruction given in the “unpacking” section.

For making audio signal connections, always remember that good and reliable connections are a basic requirement for good sound and reliable operation. Bad soldering of cables can result in intermittent audio signals or temporarily lost ground connections, hence always use good cables. In case of doubt about making proper connections, please see check the standard pin assignments required for proper operation in the following section of this manual.

B. Powering up

Following a proper power-up sequence protects your equipment – specifically speakers – and your ears. Follow the below procedure:

- Turn down all output volume controls of any equipment in your audio system.
- Switch on your audio sources first (Tuners, CD Players, PC's with soundcards, Tapedecks, etc.)
- Switch on this unit, then any connected amplifier
- Turn up the audio level on your sources if such controls are provided.
- Set the first and second stereo main volume controls of this unit to a low level.
- Make adjustments to all volume settings as needed.

For switching off, follow the inverse sequence.

C. Use

Apart from using good equipment, good sound comes from using it correctly. Level setting mistakes are one of the common reasons why even good equipment may not perform as desired. For setting levels, please be reminded that two guidelines need to be followed:

- Avoid distortion by leaving some headroom. Never overrun any audio-equipment's inputs. Level meters and displays allow you to make sure that signals do not enter critical levels.
- Avoid unnecessary amplification by using as little attenuation as possible. For example, if you turn down the input gain of a mixer to minimum, and then increase the main output of the mixer to maximum to drive your amplifier properly, you will create unnecessary noise, as you first dispose of some already existing signal level, and then later apply amplification (tainted with noise) to make it up.

Obviously, these two requirements are marking a levelling window that the operator must match to achieve a good sound with as little distortion and noise as possible.



WARNING - HEALTH RISK

Excessive volume levels on headphones or other sound systems may cause hearing damage. Always turn the volume control to minimum when you switch the unit on, and avoid prolonged exposure to sound pressure levels exceeding 90dB.

D. Practical use of the Media Player / FM Tuner

To get familiar with the media player / FM tuner part of this unit, prepare a solid state media of 16GB or less memory size, formatted in FAT32, and loaded with the following content:

- A Number of folders which are generated on the media in the sequence they are supposed to be listed on the unit later, with folder names not longer than 10 digits
- MP3 files stored in each folder with file names possibly not longer than 30 digits and sufficient differences in the first 8 digits if concise sorting is required.
- A specific folder named "Jingles" with up to three jingle files inside, named "j1_01.mp3", "j2_02.mp3" and "j3_03.mp3".

Put the unit into operation by powering it up via the power switch [38], and set the media playewr volume to a suitable level [29]. Turn the first and second stereo main outputs to a low output volume [controls 32 and 35 - these can be adjusted later to the desired volume]. Choose the desired operation mode for the media player/tuner (FM or Media play) via the button [48]. If you select Media play, the unit will show "No Media". Insert the prepared solid state media, and the unit will show "READ" and count down while loading the file directory structure. Once done, the available folders will be shown for selection. Select the desired folder via the dial [41] and confirm by pressing the dial; the unit will now show the MP3 files available in the chosen folder. Scroll with the dial [41] and confirm by pressing the dial and the chosen MP3 track will start to play. Replay can be paused or stopped via the button [43], and the play mode and play sequence can be set by the buttons [44/45]. The time display can be set to remaining or elapsed via button [46]. You can choose the next song according to the selected play sequence by the dial [41], simply turn for scrolling and press for confirmation. To change the folder, press the folder level button [42] and the unit will show the folder directory; turn the dial [41] to scroll for choices and press the dial to choose a new folder. Inside the folder, the track selection follows the above description.

To change to FM mode, press the source selection button [48]. The unit will change to FM reception and you will show either the current tuning frequency or the current station preset. To change between station preset display and tuning frequency display, press the dial [41] once. Turning the dial then either tunes to a new frequency or changes the station preset in a sequential manner. Store a new station preset by selecting the tuning frequency display via pressing [41], then tune to the frequency to be stored, then press the FolderLevel/Store button [42] and select the preset number to be stored by scrolling with the dial [41]. Press the FolderLevel/Store button [42] again to confirm storage. The newly stored preset is now available. Note that the FM tuner will show the station name instead of a frequency if the station broadcasts a RDS PS data set; only PS [station name] data will be displayed, all other RDS data will be ignored.

To insert a jingle on-the-spot into the running program material [regardless of whether Media play or FM mode], simply press one of the three Jingle buttons and the corresponding jingle in the JINGLES folder will be played immediately and once, while the program progresses in the background. To activate scheduled jingle replay, press the J1 [jingle 1] button longer than 2 seconds, until the LED [50] is lit. The jingles will now be played in a 1-2-3 sequence and then loop, with every jingle being followed by a number of minutes of background music as determined by the jingle files' name [stated in minutes xx in the jingle files _xx file name section]. If less than 3 jingles are stored in the JINGLES folder on the solid state memory media, the loop is expedited after the last available jingle. If you want to leave scheduled jingle replay, press the J1 button again for more than 2 seconds.

Technical Specifications

Signal/Noise.....	>82dB (Line)	AC IN (US version).....	AC110-120V~ 60Hz
Crosstalk Damping.....	>65dB (Line)	Power consumption.....	max. 18W
THD.....	<0.05% (Line)	Dimensions.....	W483(427)xH44.5xD183.5mm
Frequency response.....	20Hz – 20 kHz		(parentheses = without rack ears)
AC IN (EU version).....	AC220-250V~ 50Hz	Weight.....	2.2kg

Connections

This unit uses the below connector types, for which the pin assignment must comply with the following specification. Balanced connections are to be preferred over unbalanced connections where applicable and feasible. Avoid unbalanced connections exceeding 2m of cable length.

	Structure	Balanced connection	Unbalanced connection
6.35mm TRS-stereo		red = tip black = ring shield = sleeve	red = tip shield = sleeve+ring
6.35mm TRS-mono		red = tip black = sleeve shield = uncon.	red = tip shield = sleeve
3.5mm TRS-stereo		red = tip black = ring shield = sleeve	red = tip shield = sleeve+ring
RCA		red = tip black = sleeve shield = uncon.	red = tip shield = sleeve

CABLE Types

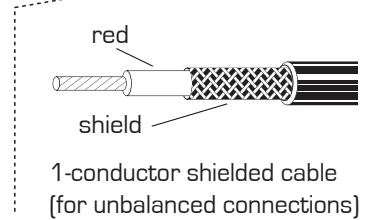
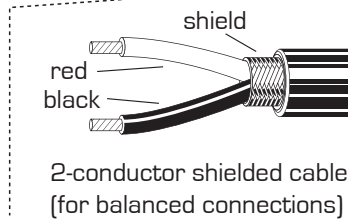

Block Diagram

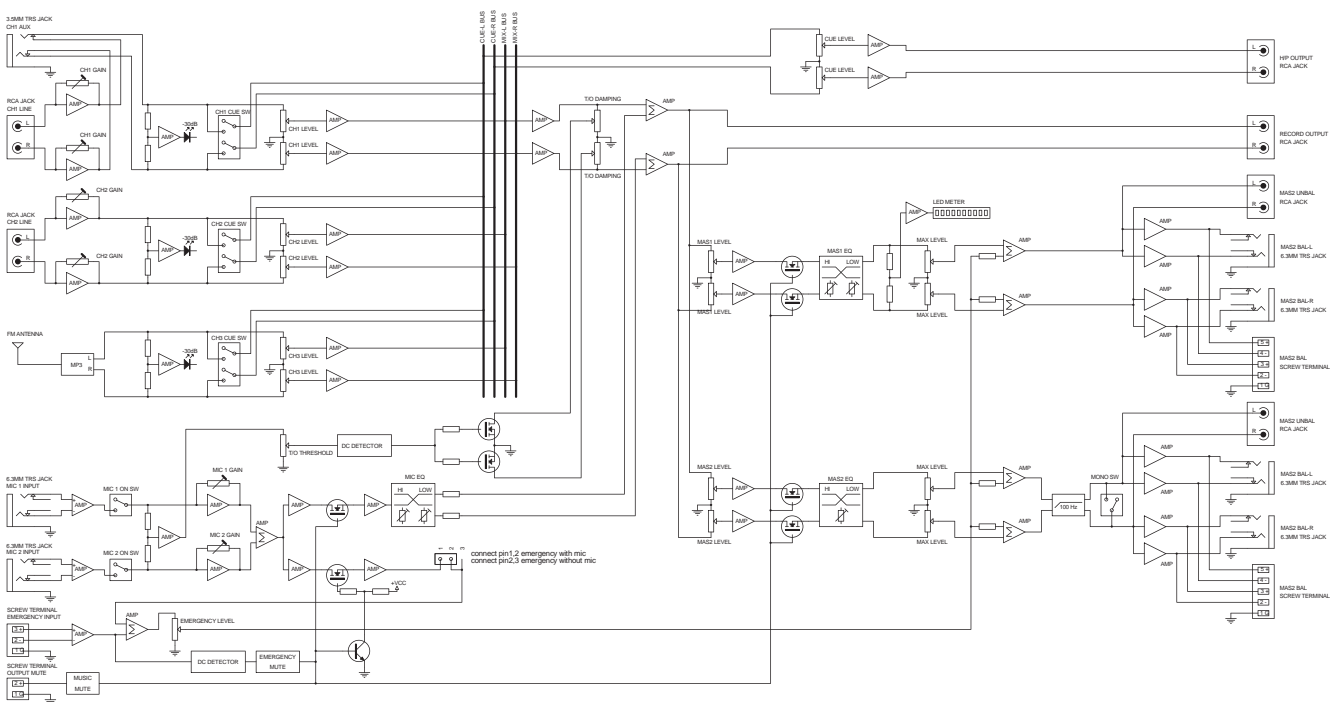

EC Declaration of Conformity

Manufacturer: Adelto Technologies Limited
Address: Vanguard Way, Shoeburyness, Essex SS3 9QY, UK

We declare on our own responsibility, that the equipment

Hill Audio IMM2320

is in conformity with the following directives and standards or regulations:

EMC Directive 2004/108/EC

EN55103-1:2009 (Emissions)

EN55103-2:2009 (Immunity)

EN61000-3-2:2006 + A1:2009 + A2:2009

EN61000-3-3:2008

LVD Directive 2006/95/EC

EN60065:2002 A1:2006 + A11:2008 + A2:2010

ROHS Directive 2002/95/EC

and is marked as follows:



Shoeburyness, 16. May 2014
Place and date of issuing

Authorized Signature