

LEDJ

Libretto Mini RGBAL Fresnel

User Manual



Order codes: LEDJ603

WARNING

FOR YOUR OWN SAFETY, PLEASE READ THIS USER MANUAL CAREFULLY BEFORE YOUR INITIAL START-UP!

- Before your initial start-up, please make sure that there is no damage caused during transportation.
- Should there be any damage, consult your dealer and do not use the equipment.
- To maintain the equipment in good working condition and to ensure safe operation, it is necessary for the user to follow the safety instructions and warning notes written in this manual.
- Please note that damages caused by user modifications to this equipment are not subject to warranty.



IMPORTANT:

The manufacturer will not accept liability for any resulting damages caused by the non-observance of this manual or any unauthorised modification to the equipment.

- Never let the power cable come into contact with other cables. Handle the power cable and all mains voltage connections with particular caution!
- Never remove warning or informative labels from the unit.
- Do not open the equipment and do not modify the unit.
- Do not connect this equipment to a dimmer pack.
- Do not switch the equipment on and off in short intervals, as this will reduce the system's life.
- Only use the equipment indoors.
- Do not expose to flammable sources, liquids or gases.
- Always disconnect the power from the mains when equipment is not in use or before cleaning! Only handle the power-cable by the plug. Never pull out the plug by pulling the power-cable.
- Make sure that the available mains supply voltage is between 100~240V AC, 50/60Hz.
- Make sure that the power cable is never crimped or damaged. Check the equipment and the power cable periodically.
- If the equipment has been exposed to drastic temperature fluctuation (e.g. after transportation), do not connect power or switch it on immediately. The arising condensation might damage the equipment. Leave the equipment switched off until it has reached room temperature.
- Never touch the fixture during operation as it may be hot.
- If the equipment is dropped or damaged, disconnect the mains power supply immediately and have a qualified engineer inspect the equipment before operating again.
- If your product fails to function correctly, stop use immediately. Pack the unit securely (preferably in the original packing material), and return it to your Pro Light dealer for service.
- Only use fuses of same type and rating.
- Repairs, servicing and power connection must only be carried out by a qualified technician. THIS UNIT CONTAINS NO USER SERVICEABLE PARTS.
- This lighting fixture is for professional use only - it is not designed for or suitable for household use. The product must be installed by a qualified technician in accordance with local territory regulations. The safety of the installation is the responsibility of the installer. The fixture presents risks of severe injury or death due to fire hazards, electric shock and falls.
- Warning! Risk Group 2 LED product according to EN 62471. Do not view the light output with optical instruments or any device that may concentrate the beam.
- WARRANTY: Two years from date of purchase.

OPERATING DETERMINATIONS

If this equipment is operated in any other way, than those described in this manual, the product may suffer damage and the warranty becomes void. Incorrect operation may lead to danger e.g: short-circuit, burns and electric shocks etc.

Do not endanger your own safety and the safety of others!

Incorrect installation or use can cause serious damage to people and/or property.

Libretto Mini RGBAL Fresnel

The Libretto RGBAL is a 60W five-colour COB LED Fresnel with a high CRI. This lightweight, compact fixture comes supplied with barn door, and is suited to gallery, museum and theatres applications. It features a manually adjustable beam angle from 17° to 34°, and control is via both DMX and the on-board menu, which allows access to the manual dimming modes along with dimming curves.

- 1 x 60W five-colour COB LED (RGBAL)
- Manually adjustable beam angle: 17° - 34°
- 17° - 1849 Lux @ 2m, 34° - 749 Lux @ 2m
- Refresh rate: 900Hz, 1000Hz, 1200Hz, 1500Hz, 2500Hz, 4000Hz, 5000Hz, 10KHz, 15KHz or 20KHz selectable
- CRI: 93
- DMX channels: 2/3/5/7/9 or 13 selectable
- 0-100% dimming
- 4 dimming curves: Linear, square law, inverse square law and S-curve
- Variable strobe
- 4 button menu with OLED display
- powerCON input/output
- 5-Pin XLR input/output
- Fan cooled
- Rear positioning handle



Specifications	Libretto Mini RGBAL Fresnel
Power consumption	62W
Power supply	100-240V,50/60Hz
Fuse	T1A 250V
Dimensions	295 x 170 x 370mm
Weight	2.8kg
Order code	LEDJ603

17° - Lux					
FULL ON	7396	1849	822	462	296
R	5300	1325	589	331	212
G	7208	1802	801	450	288
B	2152	538	239	134	86
A	3340	835	371	209	134
L	6992	1748	777	437	280
34° - Lux					
FULL ON	2996	749	333	187	120
R	1812	453	201	113	72
G	2812	703	312	176	112
B	860	215	95	54	34
A	1212	303	135	76	48
L	2964	741	329	185	119

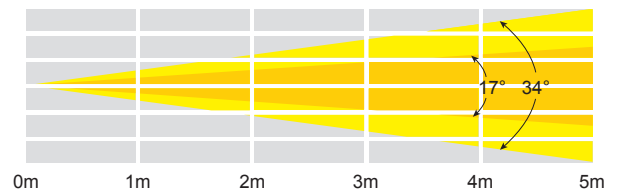

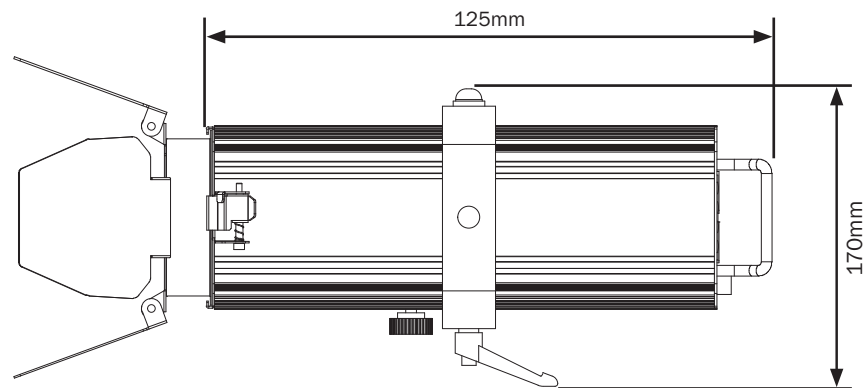
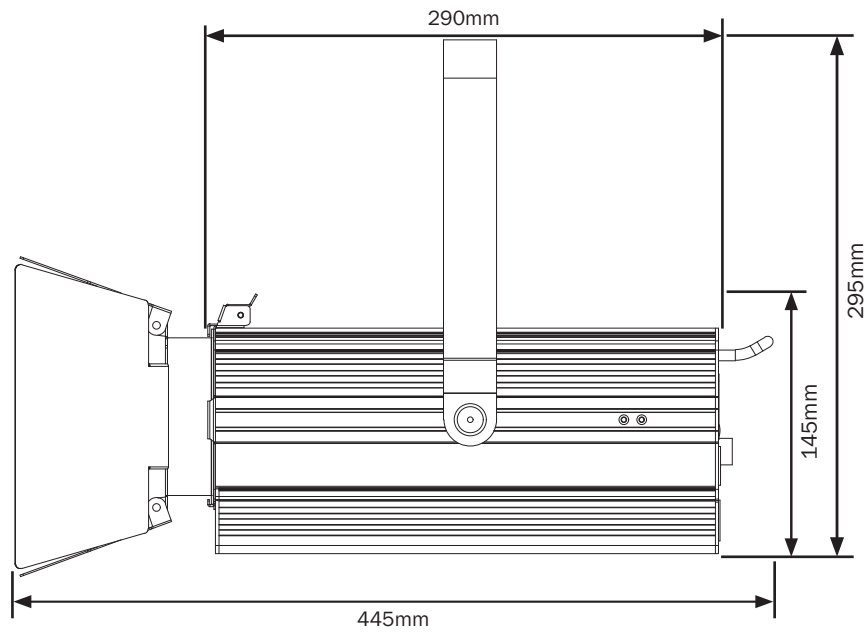
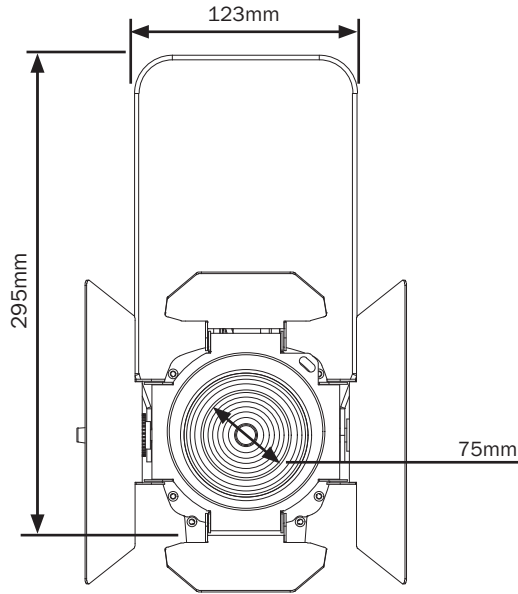

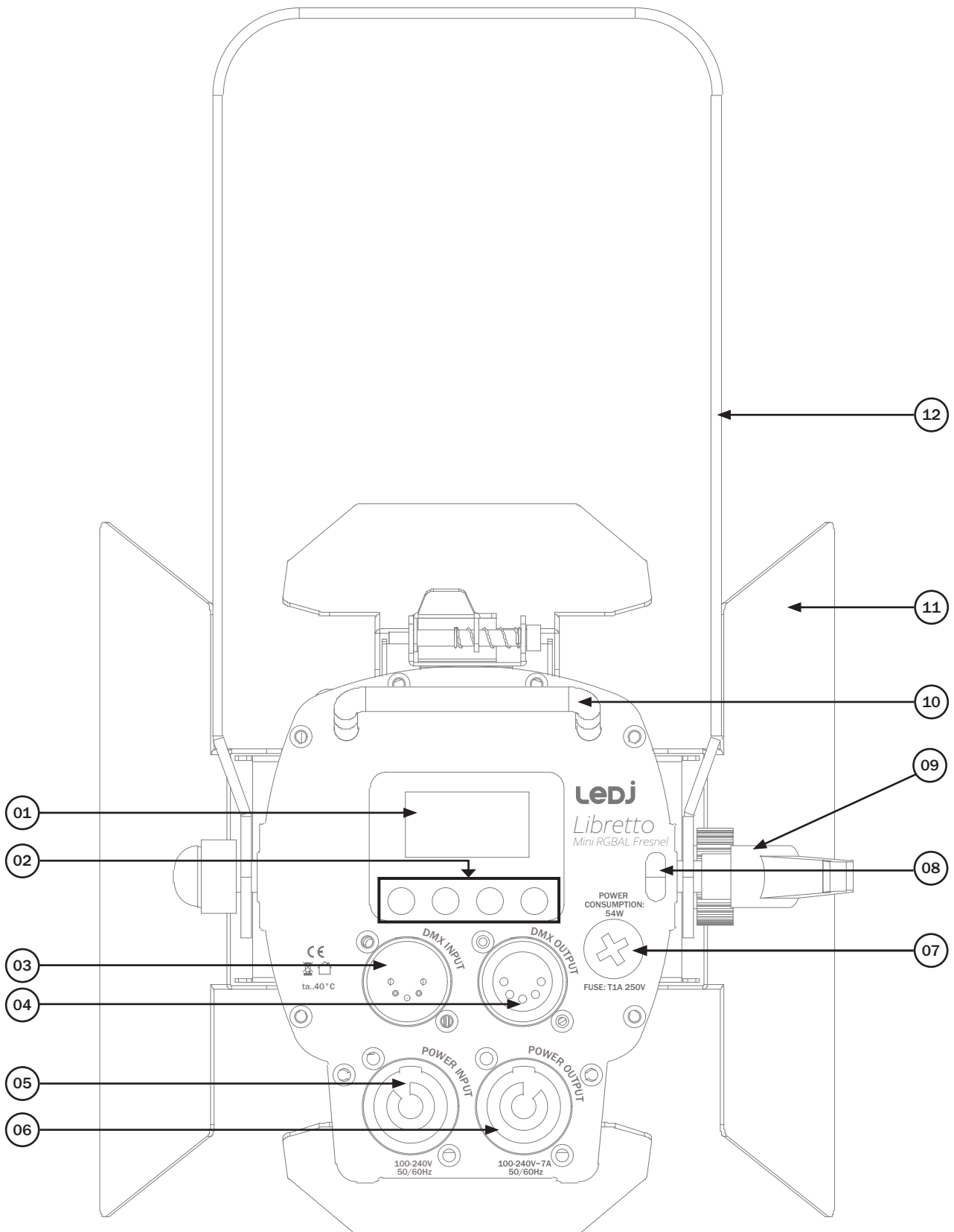

01 - OLED display
 02 - Function buttons
 03 - 5-Pin DMX input
 04 - 5-Pin DMX output

05 - powerCON input
 06 - powerCON output
 07 - Fuse T1A 250V
 08 - Safety eye

09 - Hanging bracket
 adjustment knob
 10 - Positioning handle
 11 - Barn door
 12 - Hanging bracket

In the box: **1 x fixture,**
1 x barndoor,
1 x gel frame &
1 x power cable

Before installing the fixture, the supporting structure (ie. truss) must be able to hold a minimum of 10 times the fixtures weight without any deformation (eg. 15kg - 150kg point load). The fixture must be secured with a secondary safety attachment when being installed (ie. an appropriate safety cable). Never stand directly below the fixture when mounting, removing, and/or servicing.

Overhead installation requires experience and qualifications to calculate working load limits, the material being used at the installation area and periodic safety inspections of the fixture and installation material. If you do not have the relevant experience and/or qualifications please do not attempt the installation yourself. The installation should be checked annually by a qualified person.

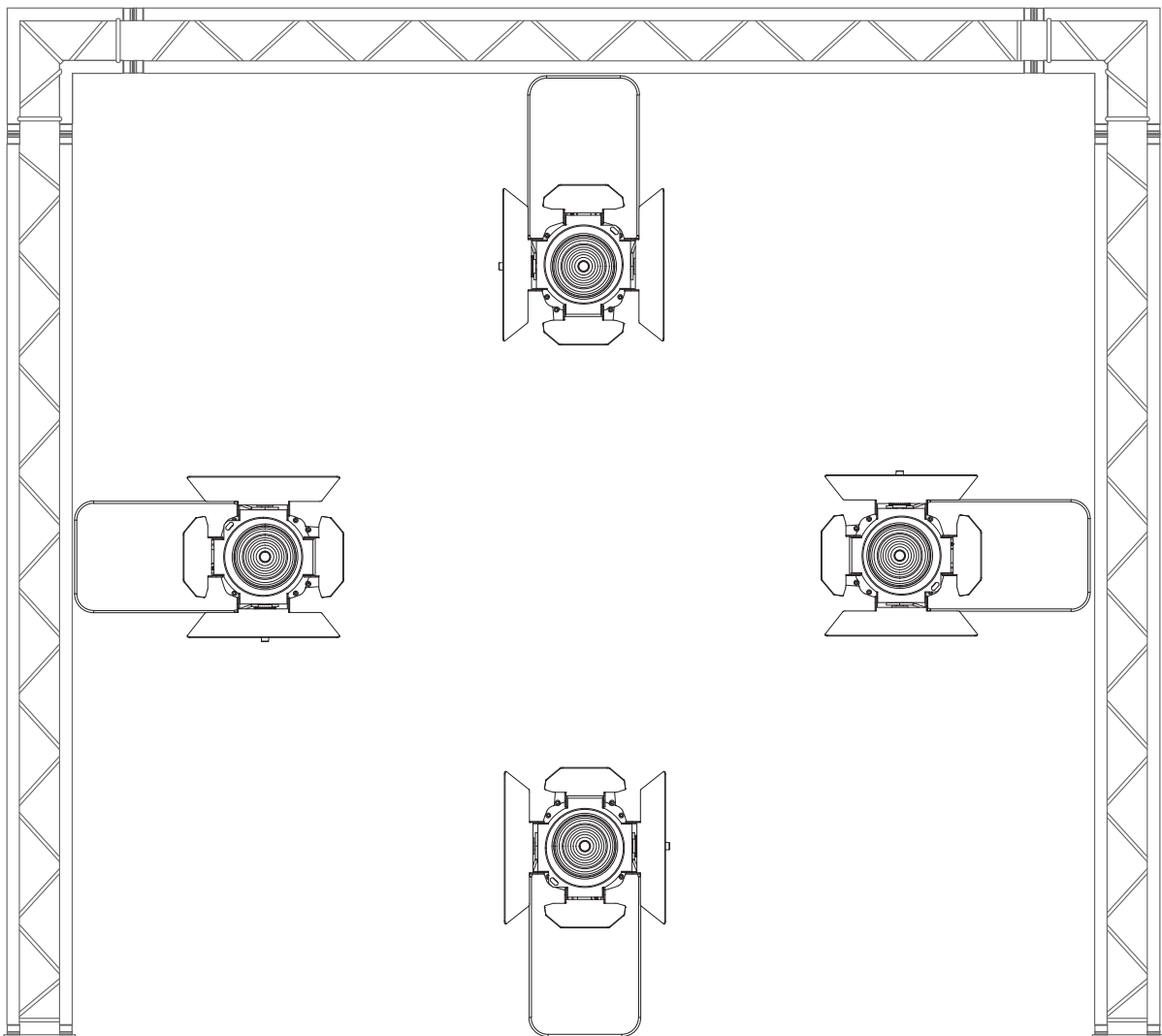

The Libretto Mini RGBAL Fresnel can be operated in a number of mounting positions as shown in the diagram above, hanging upside-down from the ceiling or truss, mounting sideways on truss or stood upright on a flat level surface. Always use a safety wire as an extra safety precaution to prevent damage/injury in the event a clamp fails (see the next page for clamp installation). Never use the carry handles for secondary attachments.

Control Panel Menu:

The OLED control panel situated on the front of the fixture allows the user to access the menu system to adjust the fixtures settings.

When the unit has been powered on the display will show “**Libretto Mini RGBAL Fresnel**”.

The fixture will then return to its home screen.

Pressing the “**MENU**” button once will take the user to the fixtures main menu. Using the “**UP**” and “**DOWN**” buttons you can then navigate between the different options in the main menu. Pressing the “**ENTER**” button on one of these options allows you to access the sub menu where you can use the “**UP**” and “**DOWN**” buttons to select option/value required. Once the option/value has been selected press the “**ENTER**” button once more to confirm the setting.

To exit out of any of the above options, press and hold the “**MENU**” button.

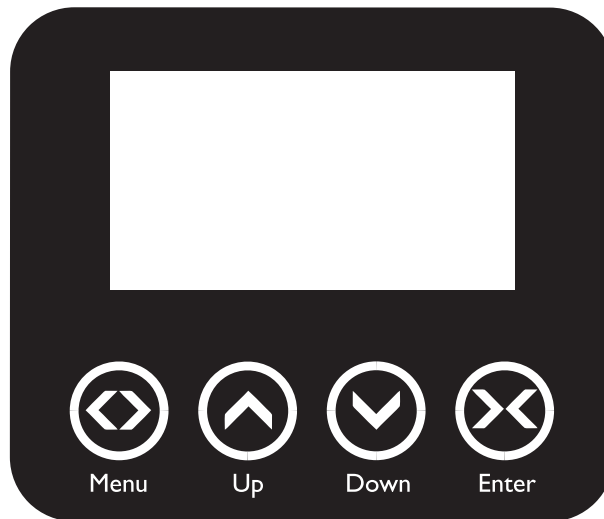

Main Menu	Sub Menu	Options/Values (Default Settings in BOLD)	Description
DMX Functions	DMX Address	001 -512	DMX Address Setting
	Channel Mode	2 Channel	DMX Channel Setting
		3 Channel	
		5 Channel	
		7 Channel	
		9 Channel	
		13 Channel	
	Dimmer Curve	Linear	Dimming Curve Setting
		Square Law	
		Inverse Squ	
S-Curve			
LED Refresh	900Hz, 1000Hz, 1200Hz , 1500Hz, 2500Hz, 4000Hz, 5000Hz, 10KHz, 15KHz or 20KHz	Refresh Rate Setting	
DMX Fail	Blackout	DMX Fail Setting	
	Last		
	Program		
Manual Dimming Mode	Red	000- 255	Manual Mode Setting
	Green	000- 255	
	Blue	000- 255	
	Amber	000- 255	
	Lime	000- 255	
	Flash	00 -15	
Auto Mode	Auto Fade	1 -16	Auto Mode Setting
	Auto Change	1 -16	
	Speed	1-16 (4)	
Static Colour Mode	Colour	00-64 (01)	Static Colour Setting
	CCT	xxxxk / Off	
	Flash	0 -15	
Display Settings	Display Backlight Auto Off	On	Backlight Setting
		Off	
	Display Inverse	No Yes	Display Inverse Setting
	Display Contrast	1-10 (10)	Display Brightness Setting
Fixture Information	Hours	XXX	Fixture Run Time
	Firmware Version	CPU-A V 1.0 B 1.0	Fixture Firmware Version
Special Functions	Factory Settings	Press Up and Down button together	Default Factory Settings

2 channel mode:

Channel	Value	Function
1	000-009	No function
	010-021	1800K
	022-034	1900K
	035-047	2000K
	048-060	2100K
	061-073	2200K
	074-086	2300K
	087-099	2400K
	100-112	2500K
	113-125	2600K
	126-138	2700K
	139-151	2800K
	152-164	2900K
	165-178	3000K
	178-190	3100K
	191-203	3200K
	204-216	4400K
217-229	5600K	
230-242	7200K	
243-255	10000K	
		Colour temperature presets
2	000-255	Master dimmer (0-100%)

5 channel mode:

Channel	Value	Function
1	000-255	Red dimmer (0-100%)
2	000-255	Green dimmer (0-100%)
3	000-255	Blue dimmer (0-100%)
4	000-255	Amber dimmer (0-100%)
5	000-255	Lime dimmer (0-100%)

7 channel mode:

Channel	Value	Function
1	000-255	Red dimmer (0-100%)
2	000-255	Green dimmer (0-100%)
3	000-255	Blue dimmer (0-100%)
4	000-255	Amber dimmer (0-100%)
5	000-255	Lime dimmer (0-100%)
6	000-255	Master dimmer (0-100%)
7	000-020	Linear
	021-040	Square Law
	041-060	Inverse Square Law
	061-080	S-Curve
	081-255	Default (set via menu)
		Dimming curve

3 channel mode:

Channel	Value	Function
1	000-255	Colour macros (See pages 12-13)
2	000-031	LED off
	032-063	LED on
	064-095	Strobe (slow-fast)
	096-127	LED on
	128-159	Strobe pulse (slow-fast)
	160-191	LED on
	192-223	Strobe random (slow-fast)
	224-255	LED on
3	000-255	Master dimmer (0-100%)

9 channel mode:

Channel	Value	Function	
1	000-255	Red dimmer (0-100%)	
2	000-255	Green dimmer (0-100%)	
3	000-255	Blue dimmer (0-100%)	
4	000-255	Amber dimmer (0-100%)	
5	000-255	Lime dimmer (0-100%)	
6	000-031	LED off	
	032-063	LED on	
	064-095	Strobe (slow-fast)	
	096-127	LED on	
	128-159	Strobe pulse (slow-fast)	
	160-191	LED on	
	192-223	Strobe random (slow-fast)	
	224-255	LED on	
7	000-255	Master dimmer (0-100%)	
8	000-020	Linear	Dimming curve
	021-040	Square Law	
	041-060	Inverse Square Law	
	061-080	S-Curve	
	081-255	Default (set via menu)	
9	000-015	Default (set via menu)	
	016-040	900Hz	
	041-065	1000Hz	
	066-090	1200Hz	
	091-115	1500Hz	
	116-140	2500Hz	
	141-165	4000Hz	
	166-190	5000Hz	
	190-215	10KHz	
	216-240	15KHz	
	241-255	20KHz	

13 channel mode:

Channel	Value	Function
1	000-255	Red dimmer (0-100%)
2	000-255	Green dimmer (0-100%)
3	000-255	Blue dimmer (0-100%)
4	000-255	Amber dimmer (0-100%)
5	000-255	Lime dimmer (0-100%)
6	000-031	LED off
	032-063	LED on
	064-095	Strobe (slow-fast)
	096-127	LED on
	128-159	Strobe pulse (slow-fast)
	160-191	LED on
	192-223	Strobe random (slow-fast)
	224-255	LED on
7	000-255	Master dimmer (0-100%)
8	000-009	No function
	010-021	1800K
	022-034	1900K
	035-047	2000K
	048-060	2100K
	061-073	2200K
	074-086	2300K
	087-099	2400K
	100-112	2500K
	113-125	2600K
	126-138	2700K
	139-151	2800K
	152-164	2900K
	165-178	3000K
	178-190	3100K
	191-203	3200K
	204-216	4400K
	217-229	5600K
230-242	7200K	
243-255	10000K	

Colour temperature presets

Channel	Value	Function
9	000-051	No function
	052-102	Colour macro mode
	103-153	Colour change mode
	154-204	Colour fade mode
	205-255	Colour hold
10	000-042	Colour Change 1/ Colour fade 1
	043-084	Colour Change 2/ Colour fade 2
	085-127	Colour Change 3/ Colour fade 3
	128-170	Colour Change 4/ Colour fade 4
	171-213	Colour Change 5/ Colour fade 5
	213-255	Colour Change 6/ Colour fade 6
11	000-255	No function
		Speed (slow-fast) (CH9 value 103-255)
12	000-020	Linear
	021-040	Square Law
	041-060	Inverse Square Law
	061-080	S-Curve
	081-255	Default (set via menu)
13	000-015	Default (set via menu)
	016-040	900Hz
	041-065	1000Hz
	066-090	1200Hz
	091-115	1500Hz
	116-140	2500Hz
	141-165	4000Hz
	166-190	5000Hz
	190-215	10KHz
	216-240	15KHz
	241-255	20KHz

(CH10 value 000-255)

Colour macro mode

Dimming curve

Colour Chart:

Menu	DMX Values	Colour Temperature	Red	Green	Blue	Amber	Lime
Colour 1	001-004	-	000	255	255	001	116
Colour 2	005-008	-	127	255	212	001	124
Colour 3	009-012	-	151	125	003	255	043
Colour 4	013-016	-	000	000	255	001	000
Colour 5	017-020	-	138	043	226	001	177
Colour 6	021-024	-	223	108	007	255	077
Colour 7	025-028	-	165	042	042	001	200
Colour 8	029-032	-	095	158	160	044	071
Colour 9	033-036	-	171	036	000	120	255
Colour 10	037-040	-	127	255	000	001	255
Colour 11	041-044	-	210	105	030	001	022
Colour 12	045-048	-	255	015	018	255	174
Colour 13	049-052	-	100	149	237	003	000
Colour 14	053-056	-	255	000	010	255	144
Colour 15	057-060	-	220	020	060	001	000
Colour 16	061-064	-	000	255	255	000	012
Colour 17	065-068	-	006	000	139	001	003
Colour 18	069-072	-	000	139	139	002	005
Colour 19	073-076	-	000	111	000	001	024
Colour 20	077-080	-	255	000	002	021	003
Colour 21	081-084	-	188	000	003	255	044
Colour 22	085-088	-	255	012	000	077	062
Colour 23	089-092	-	255	130	25	229	030
Colour 24	093-096	-	140	000	139	002	135
Colour 25	097-100	-	255	140	000	001	000
Colour 26	101-104	-	153	050	204	001	005
Colour 27	105-108	-	143	188	143	001	035
Colour 28	109-112	-	072	061	139	004	002
Colour 29	113-116	-	000	206	209	002	002
Colour 30	117-120	-	255	000	004	011	008
Colour 31	121-124	-	148	000	211	005	002
Colour 32	125-128	-	255	020	147	001	000
Colour 33	129-132	-	000	191	255	002	003
Colour 34	133-136	-	160	000	26	000	004
Colour 35	137-140	-	034	139	034	001	001
Colour 36	141-144	-	255	000	255	002	000
Colour 37	145-148	-	255	215	000	001	001
Colour 38	149-152	-	005	255	190	003	011

Colour Chart (cont):

Menu	DMX Values	Colour Temperature	Red	Green	Blue	Amber	Lime
Colour 39	153-156	-	012	255	062	095	049
Colour 40	157-160	-	005	209	255	015	170
Colour 41	161-164	-	000	005	128	005	005
Colour 42	165-168	-	255	105	180	002	001
Colour 43	169-172	-	007	255	025	070	077
Colour 44	173-176	-	147	164	212	000	002
Colour 45	177-180	-	002	255	015	003	019
Colour 46	181-184	-	000	038	086	000	000
Colour 47	185-188	-	255	000	005	121	010
Colour 48	189-192	-	005	148	209	005	019
Colour 49	193-196	-	001	255	062	093	044
Colour 50	197-200	2300K	150	004	004	255	255
Colour 51	201-204	2600K	140	015	008	255	255
Colour 52	205-208	2800K	130	025	010	255	255
Colour 53	209-212	3100K	110	030	015	255	255
Colour 54	213-216	3400K	100	050	020	255	255
Colour 55	217-220	7000K	075	110	070	255	255
Colour 56	221-224	8000K	075	125	085	255	255
Colour 57	225-228	3800K	090	060	025	255	255
Colour 58	229-232	4100K	080	071	030	255	255
Colour 59	233-236	4500K	080	085	038	255	255
Colour 60	237-240	4900K	080	095	046	255	255
Colour 61	241-244	5500K	075	110	055	255	255
Colour 62	245-248	6000K	075	110	070	255	255
Colour 63	249-252	9000K	065	045	097	255	255
Colour 64	253-255	9900K	055	165	117	255	255

Setting the DMX address:

The DMX mode enables the use of a universal DMX controller. Each fixture requires a “start address” from 1- 512. A fixture requiring one or more channels for control begins to read the data on the channel indicated by the start address. For example, a fixture that occupies or uses 7 channels of DMX and was addressed to start on DMX channel 100, would read data from channels: 100, 101, 102, 103, 104, 105 and 106. Choose a start address so that the channels used do not overlap. E.g. the next unit in the chain starts at 107.

DMX 512:

DMX (Digital Multiplex) is a universal protocol used as a form of communication between intelligent fixtures and controllers. A DMX controller sends DMX data instructions from the controller to the fixture. DMX data is sent as serial data that travels from fixture to fixture via the DATA “IN” and DATA “OUT” XLR terminals located on all DMX fixtures (most controllers only have a data “out” terminal).

DMX linking:

DMX is a language allowing all makes and models of different manufactures to be linked together and operate from a single controller, as long as all fixtures and the controller are DMX compliant. To ensure proper DMX data transmission, when using several DMX fixtures try to use the shortest cable path possible. The order in which fixtures are connected in a DMX line does not influence the DMX addressing. For example; a fixture assigned to a DMX address of 1 may be placed anywhere in a DMX line, at the beginning, at the end, or anywhere in the middle. When a fixture is assigned a DMX address of 1, the DMX controller knows to send DATA assigned to address 1 to that unit, no matter where it is located in the DMX chain.

DATA cable (DMX cable) requirements (for DMX operation):

This fixture can be controlled via DMX-512 protocol. The DMX address is set on the back of the unit. Your unit requires either a standard 3-pin or 5-pin XLR connector for data input/output, see images below.

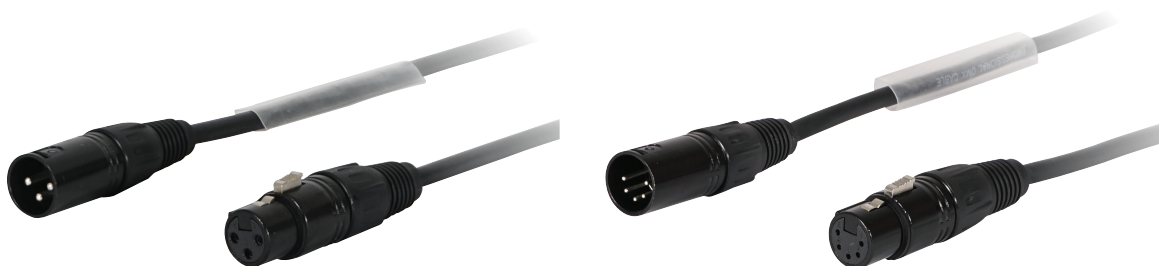

Further DMX cables can be purchased from all good sound and lighting suppliers or Prolight Concepts dealers.

Please quote:	3-Pin:	CABL10 - 2m	CABL11 - 5m	CABL12 - 10m
	5-Pin:	CABL185 - 2m	CABL187 - 5m	CABL188 - 10m

Also remember that DMX cable must be daisy chained and cannot be split.

Notice:

Be sure to follow the diagrams below when making your own cables. Do not connect the cables shield conductor to the ground lug or allow the shield conductor to come in contact with the XLRs outer casing. Grounding the shield could cause a short circuit and erratic behaviour.

Pin Configuration	
3-Pin	5-Pin
	Pin 1 - Ground
	Pin 2 - Negative
	Pin 3 - Positive
-	Pin 4 - N/C
-	Pin 5 - N/C

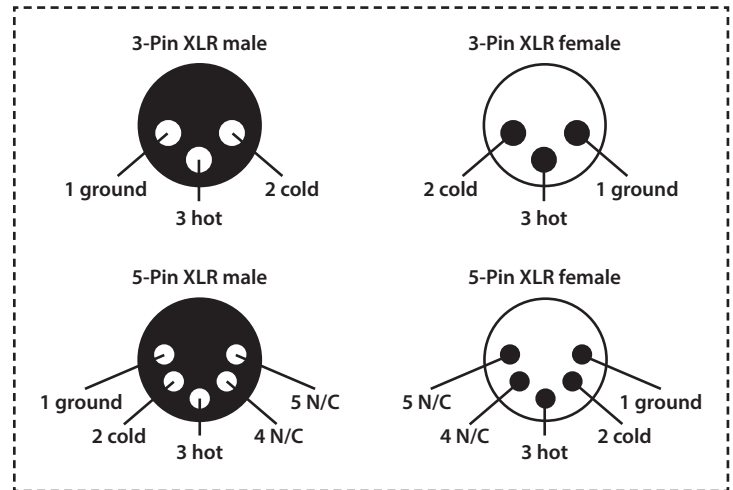
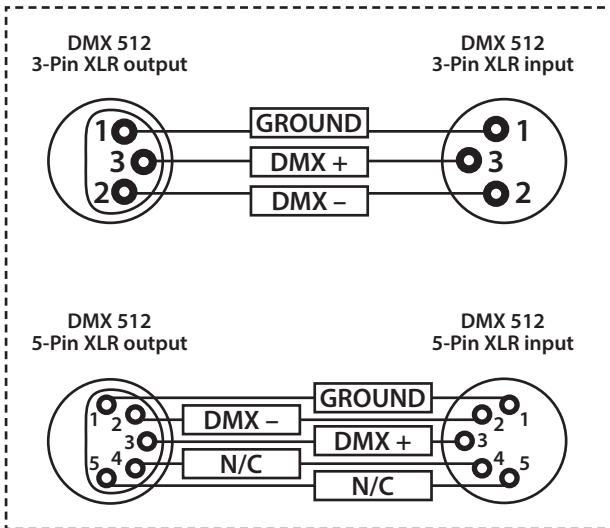

Line termination:

When longer runs of cable are used, you may need to use a terminator on the last unit to avoid erratic behaviour.

Using a cable terminator will decrease the possibilities of erratic behaviour.

(3-pin - Order ref: CABL90,
5-pin - Order ref: CABL89)

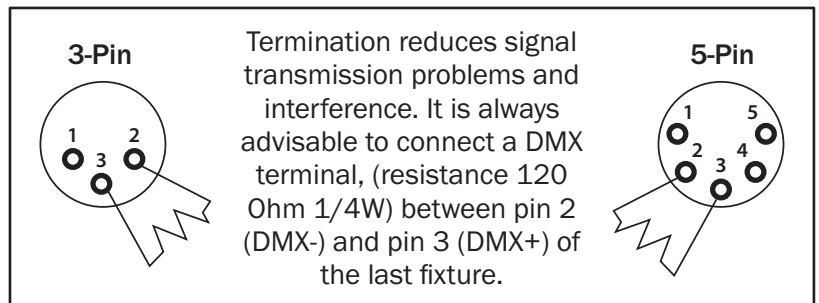

5-pin XLR DMX connectors:

Some manufactures use 5-pin XLR connectors for data transmission in place of 3-pin. 5-pin XLR fixtures may be implemented in a 3-pin XLR DMX line. When inserting standard 5-pin XLR connectors in to a 3-pin line a cable adaptor must be used. The diagram below details the correct cable conversion.

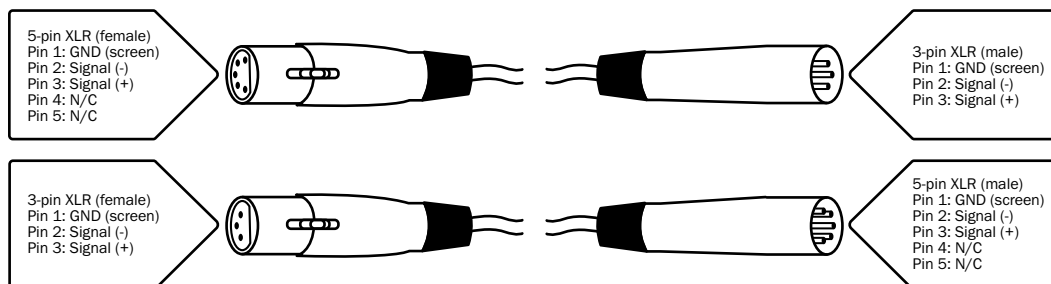

Power linking:

This fixture provides power linking via the power output on the rear allowing multiple units to be connected together. The maximum number of fixtures that can be connected is 12 fixtures @ 240V or 6 fixtures @ 120V (including the first fixture). After the maximum number of fixtures are connected a new power run will need to be started.

Please note: Caution should be used when power linking other fixtures to the Libretto Mini RGBAL Fresnel as the power consumption of other fixtures will vary. Fixtures fitted with lamps often require 2/3 times more current on startup, these may require their own power source.

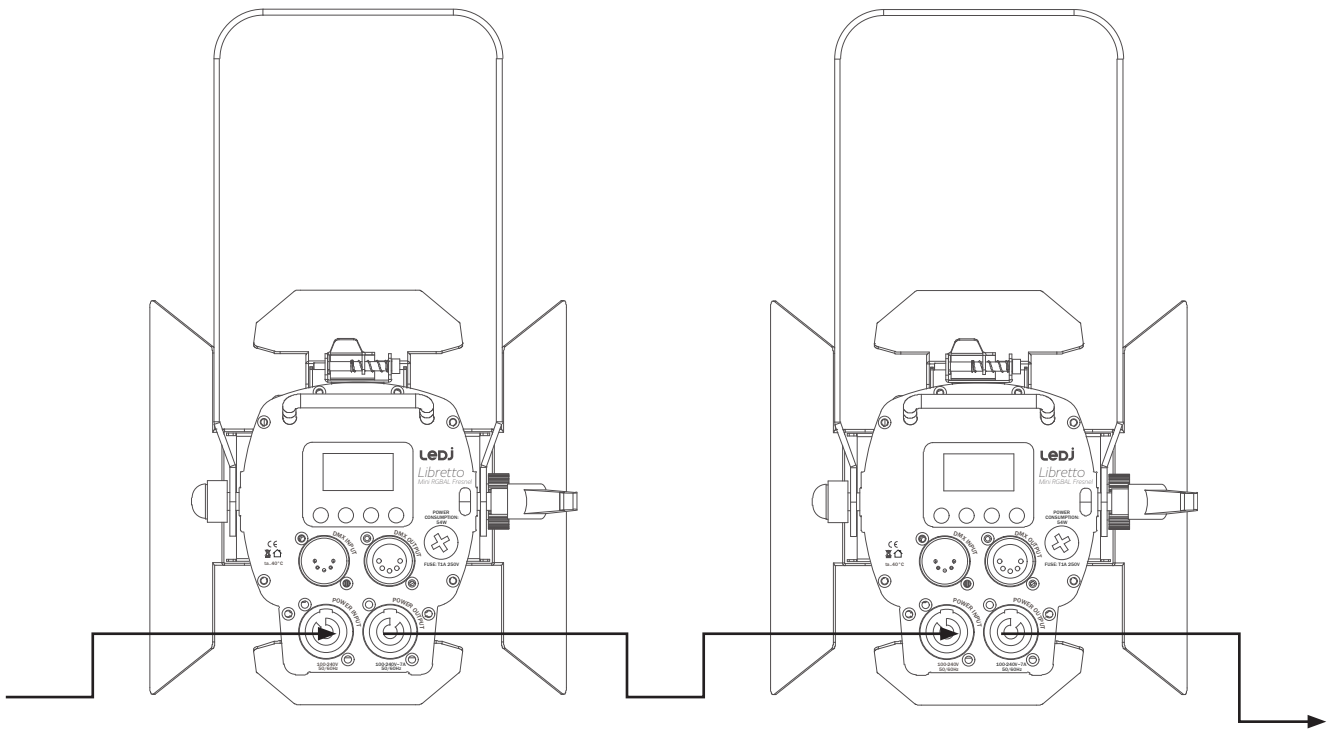



***Correct Disposal of this Product
(Waste Electrical & Electronic Equipment)***

(Applicable in the European Union and other European countries with separate collection systems)

This marking shown on the product or its literature, indicates that it should not be disposed with other household wastes at the end of its working life. To prevent possible harm to the environment or human health from uncontrolled waste disposal, please separate this from other types of wastes and recycle it responsibly to promote the sustainable reuse of material resources.

Household users should contact either the retailer where they purchased this product, or their local government office, for details of where and how they can take this item for environmentally safe recycling.

Business users should contact their supplier and check the terms and conditions of the purchase contract. This product should not be mixed with other commercial wastes for disposal.

