

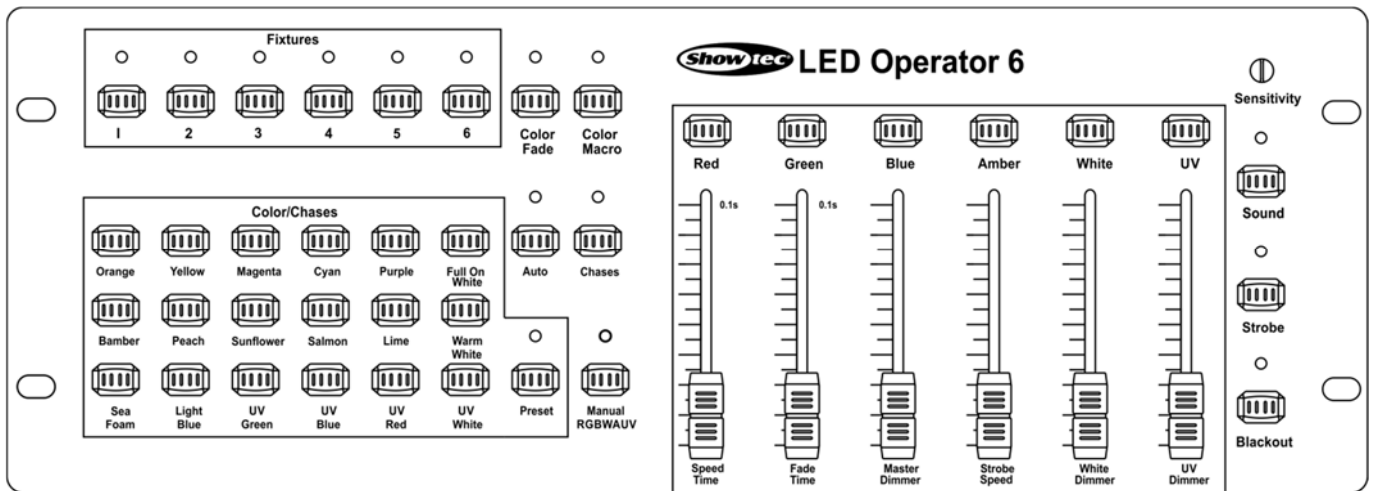

MANUAL



ENGLISH

LED Operator 6

V2

Ordercode: 50728

Table of contents

Warning	2
Unpacking Instructions	2
Safety Instructions	2
Operating Determinations.....	3
Connection with the mains	4
Return Procedure	4
Claims	4
Description of the device	5
Overview	5
Frontside	6
Backside	7
Installation	7
Set Up and Operation	7
Fixture Linking	7
Data Cabling	8
Control Modes.....	8
1. Color Presets	9
2. Color Fade	9
3. Auto Mode.....	10
4. Chase.....	10
5. RGB Offset	10
6. Color Macro.....	10
7. Sound-Override	11
8. Strobe-Override	11
9. Blackout.....	11
10. Manual RGBWAUV.....	11
Maintenance	12
Troubleshooting	12
No Light.....	12
No Response to DMX.....	12
Product Specifications	13
Dimensions	14

Warning

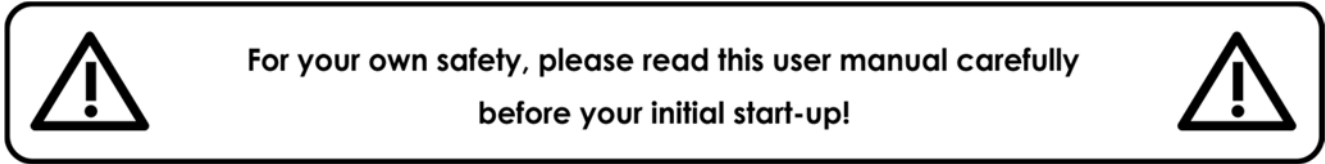

Unpacking Instructions

Immediately upon receiving this product, carefully unpack the carton and check the contents to ensure that all parts are present, and have been received in good condition. Notify the dealer immediately and retain packing material for inspection if any parts appear damaged from shipping or the carton itself shows signs of mishandling. Save the carton and all packing materials. In the event that a fixture must be returned to the factory, it is important that the fixture be returned in the original factory box and packing.

Your shipment includes:

- Showtec LED Operator 6
- DC power adapter (1,5 m)
- User manual

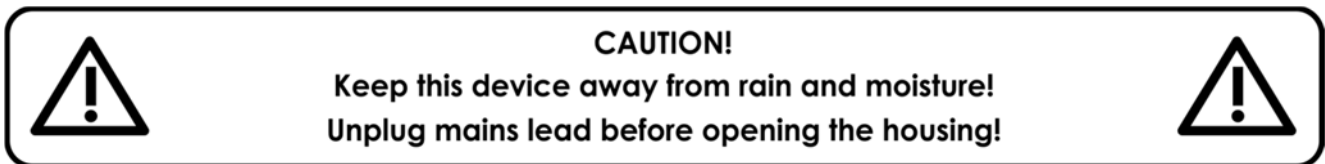
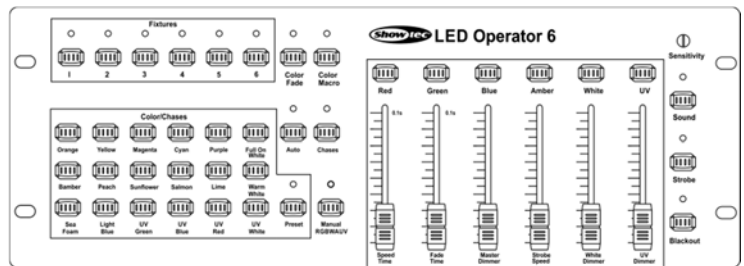

Safety Instructions

Every person involved with the installation, operation and maintenance of this device has to:

- be qualified
- follow the instructions of this manual

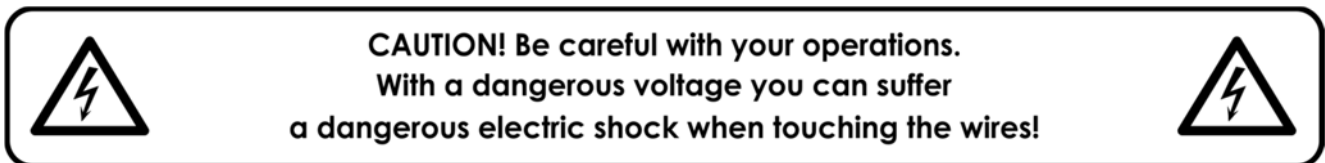

Before your initial start-up, please make sure that there is no damage caused by transportation. Should there be any, consult your dealer and do not use the device.

To maintain perfect condition and to ensure a safe operation, it is absolutely necessary for the user to follow the safety instructions and warning notes written in this manual.

Please consider that damages caused by manual modifications to the device are not subject to warranty.

This device contains no user-serviceable parts. Refer servicing to qualified technicians only.

IMPORTANT:

The manufacturer will not accept liability for any resulting damages caused by the non-observance of this manual or any unauthorized modification to the device.

- Never let the power cord come into contact with other cables! Handle the power cord and all connections with the mains with particular caution!
- Never remove warning or informative labels from the unit.
- Never use anything to cover the ground contact.
- Never leave any cables lying around.
- Do not insert objects into air vents.
- Do not open the device and do not modify the device.
- Do not connect this device to a dimmer pack.
- Do not switch the device on and off in short intervals, as this would reduce the device's life.
- Do not shake the device. Avoid brute force when installing or operating the device.
- Only use device indoor, avoid contact with water or other liquids.
- Only operate the fixture after having checked that the housing is firmly closed and all screws are tightly fastened.
- Only operate the device after having familiarized with its functions.
- Avoid flames and do not put close to flammable liquids or gases.
- Always keep case closed while operating.
- Always disconnect power from the mains, when device is not used or before cleaning! Only handle the power cord by the plug. Never pull out the plug by tugging the power cord.
- Make sure that the device is not exposed to extreme heat, moisture or dust.
- Make sure that the available voltage is not higher than stated on the rear panel.
- Make sure that the power cord is never crimped or damaged. Check the device and the power cord from time to time.
- If device is dropped or struck, disconnect mains power supply immediately. Have a qualified engineer inspect for safety before operating.
- If the device has been exposed to drastic temperature fluctuation (e.g. after transportation), do not switch it on immediately. The arising condensation water might damage your device. Leave the device switched off until it has reached room temperature.
- If your Showtec device fails to work properly, discontinue use immediately. Pack the unit securely (preferably in the original packing material), and return it to your Showtec dealer for service.
- For adult use only. Device must be installed out of the reach of children. Never leave the unit running unattended.
- The user is responsible for correct positioning and operating of the LED Operator 6. The manufacturer will not accept liability for damages caused by the misuse or incorrect installation of this device.
- This device falls under protection class I. Therefore it is essential to connect the yellow/green conductor to earth.
- Repairs, servicing and electric connection must be carried out by a qualified technician.
- WARRANTY: Till one year after date of purchase.

Operating Determinations

- This device is not designed for permanent operation. Consistent operation breaks will ensure that the device will serve you for a long time without defects.
- The minimum distance between light-output and the illuminated surface must be more than 1 meter.
- The maximum ambient temperature $t_a = 40^\circ\text{C}$ must never be exceeded.
- The relative humidity must not exceed 50 % with an ambient temperature of 40°C .
- If this device is operated in any other way, than the one described in this manual, the product may suffer damages and the warranty becomes void.
- Any other operation may lead to dangers like short-circuit, burns, electric shock, crash etc.

You endanger your own safety and the safety of others!

Connection with the mains

Connect the device to the mains with the power-plug.

Always pay attention, that the right color cable is connected to the right place.

International	EU Cable	UK Cable	US Cable	Pin
L	BROWN	RED	YELLOW/COPPER	PHASE
N	BLUE	BLACK	SILVER	NEUTRAL
	YELLOW/GREEN	GREEN	GREEN	PROTECTIVE GROUND

Make sure that the device is always connected properly to the earth!

Improper installation can cause serious damage to people and property!



Return Procedure



Returned merchandise must be sent prepaid and in the original packing, call tags will not be issued. Package must be clearly labeled with a Return Authorization Number (RMA number). Products returned without an RMA number will be refused. Highlite will not accept the returned goods or any responsibility. Call Highlite 0031-455667723 or mail aftersales@highlite.nl and request an RMA prior to shipping the fixture. Be prepared to provide the model number, serial number and a brief description of the cause for the return. Be sure to properly pack fixture, any shipping damage resulting from inadequate packaging is the customer's responsibility. Highlite reserves the right to use its own discretion to repair or replace product(s). As a suggestion, proper UPS packing or double-boxing is always a safe method to use.

Note: If you are given an RMA number, please include the following information on a piece of paper inside the box:

- 01) Your name.
- 02) Your address.
- 03) Your phone number.
- 04) A brief description of the symptoms.

Claims

The client has the obligation to check the delivered goods immediately upon delivery for any shortcomings and/or visible defects, or perform this check after our announcement that the goods are at their disposal. Damage incurred in shipping is the responsibility of the shipper; therefore the damage must be reported to the carrier upon receipt of merchandise.

It is the customer's responsibility to notify and submit claims with the shipper in the event that a fixture is damaged due to shipping. Transportation damage has to be reported to us within one day after receipt of the delivery.

Any return shipment has to be made post-paid at all times. Return shipments must be accompanied with a letter defining the reason for return shipment. Non-prepaid return shipments will be refused, unless otherwise agreed in writing.

Complaints against us must be made known in writing or by fax within 10 working days after receipt of the invoice. After this period complaints will not be handled anymore.

Complaints will only then be considered if the client has so far complied with all parts of the agreement, regardless of the agreement of which the obligation is resulting.

Description of the device

Features

The Showtec LED Operator 6 is a compact light controller equipped with very useful features:

- Power supply: 12V DC 500mA
- Power consumption: 20W
- 6 x 6 channel fixtures control
- Adjustable fade and speed
- 10 control modes: Preset, Color Fade, Auto, Chase, RGB Offset, Color Macro, Sound-Override, Strobe-Override, Blackout, Manual RGBWAUV
- Strobe control
- Sound control
- Fixtures: 6
- Channels: 36 (6 per fixture)
- RGB color presets: 18
- Chases: 18
- Connections: 3-pin DMX signal connector OUT
- Power connector: Power adapter (included)
- Dimensions: 393 x 140 x 50 mm (LxWxH)
- Weight: 1,7 kg

Overview

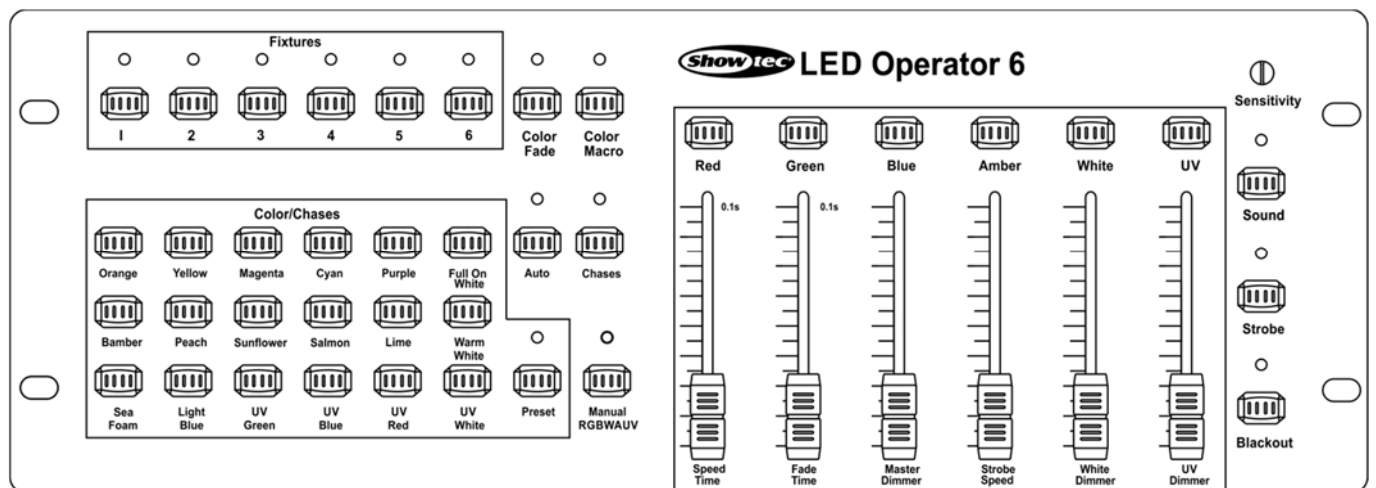

Fig. 01

Frontside

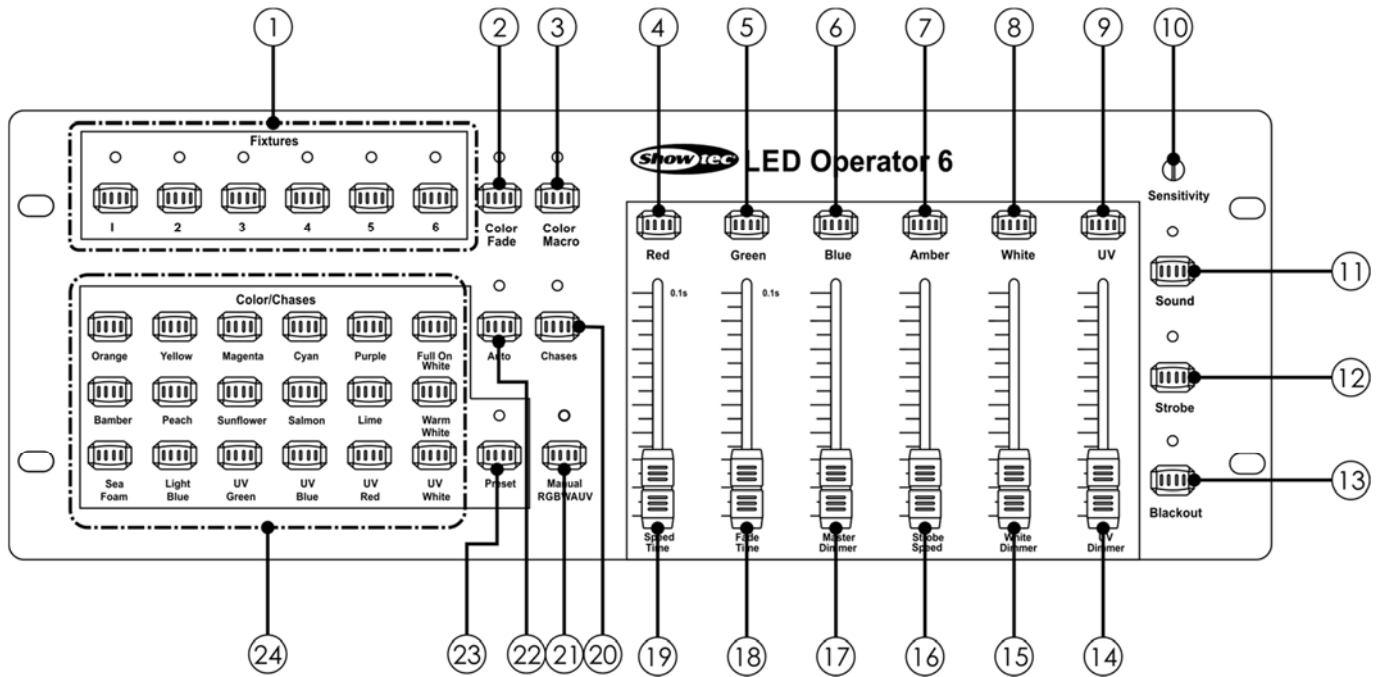

Fig. 02

- 01) Fixture buttons (1-6)
- 02) Color Fade button
- 03) Color Macro button
- 04) Red button
- 05) Green button
- 06) Blue button
- 07) Amber button
- 08) White button
- 09) UV button
- 10) Sound sensitivity control
- 11) Sound button
- 12) Strobe button
- 13) Blackout button

Press the Blackout button to enable or disable relevant DMX output. When its LED is lit, the relevant DMX output is disabled. Press the button again and the LED indicator will be switched off.

The DMX output is now reactivated.

- 14) UV Dimmer fader
- 15) White Dimmer fader
- 16) Strobe speed fader
- 17) Master Dimmer fader
- 18) Fade Time fader
- 19) Speed Time fader
- 20) Chases button
- 21) Manual RGBWAUV button
- 22) Auto button
- 23) Preset button
- 24) Color Buttons (Orange, Yellow, Magenta, Cyan, Purple, Full On White, Bamber, Peach, Sunflower, Salmon, Lime, Warm White, Sea Foam, Light Blue, UV Green, UV Blue, UV Red, UV White)

Backside

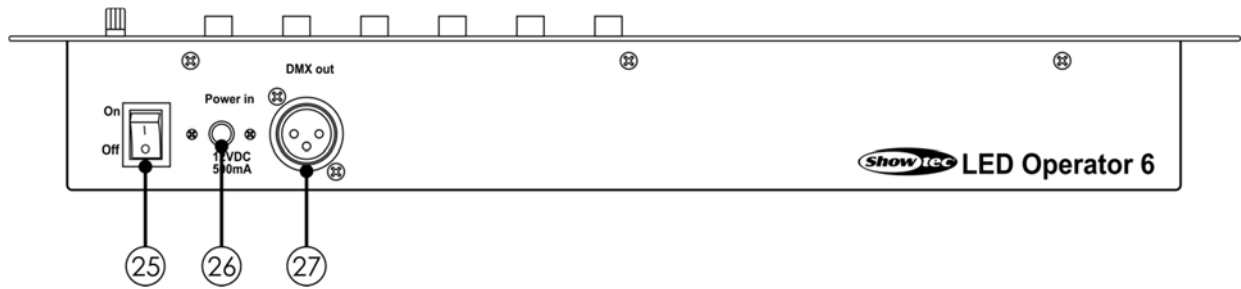

Fig. 03

- 26) Power switch ON/OFF
- 27) Power adapter 12VDC 500mA input
- 28) 3-pin DMX signal connector OUT

Installation

Remove all packing materials from the LED Operator 6. Check if all foam and plastic padding is removed. Connect all cables.

Do not supply power before the whole system is set up and connected properly.

Always disconnect from electric mains power supply before cleaning or servicing.

Damages caused by non-observance are not subject to warranty.

Set Up and Operation

Follow the directions below, as they pertain to your preferred operation mode.

Before plugging the unit in, always make sure that the power supply matches the product specification voltage. Do not attempt to operate a 120V specification product on 230V power, or vice versa.

Connect the device to the main power supply. The device can be sound-controlled as it is equipped with a built-in microphone.

Fixture Linking

You will need a serial data link to run light shows of one or more fixtures using a DMX-512 controller or to run synchronized shows on two or more fixtures set to a master/slave operating mode. The combined number of channels required by all the fixtures on a serial data link determines the number of fixtures the data link can support.

Important: Fixtures on a serial data link must be daisy chained in one single line. To comply with the EIA-485 standard no more than 30 devices should be connected on one data link. Connecting more than 30 fixtures on one serial data link without the use of a DMX optically isolated splitter may result in deterioration of the digital DMX signal.



Maximum recommended DMX data link distance: 100 meters

Maximum recommended number of fixtures on a DMX data link: 30 fixtures

Data Cabling

To link fixtures together, you must obtain data cables. You can purchase DAP Audio certified DMX cables directly from a dealer/distributor or construct your own cable. If you choose to create your own cable please use data-grade cables that can carry a high quality signal and are less prone to electromagnetic interference.

DAP Audio DMX Data Cables

- DAP Audio Basic microphone cable for allround use. bal. XLR/M 3-pin > XLR/F 3-pin. **Ordercode** FL01150 (1,5 m), FL013 (3 m), FL016 (6 m), FL0110 (10 m), FL0115 (15 m), FL0120 (20 m).
- DAP Audio X-type data cable XLR/M 3-pin > XLR/F 3-pin. **Ordercode** FLX0175 (0,75 m), FLX01150 (1,5 m), FLX013 (3 m), FLX016 (6 m), FLX0110 (10 m).
- DAP Audio cable for the demanding user with exceptional audio-qualities and connector made by Neutrik®. **Ordercode** FL71150 (1,5 m), FL713 (3 m), FL716 (6 m), FL7110 (10 m).
- DAP Audio cable for the demanding user with exceptional audio-qualities and connector made by Neutrik®. **Ordercode** FL7275 (0,75 m), FL72150 (1,5 m), FL723 (3 m), FL726 (6 m), FL7210 (10 m).
- DAP Audio 110 Ohm cable with digital signal transmission. **Ordercode** FL0975 (0,75 m), FL09150 (1,5 m), FL093 (3 m), FL096 (6 m), FL0910 (10 m), FL0915 (15 m), FL0920 (20 m).

Control Modes

There are 10 modes:

1. Preset Colors
2. Color Fade
3. Auto Mode
4. Chase
5. RGB Offset
6. Color Macro
7. Sound-override
8. Strobe-override
9. Blackout
10. Manual RGBWAUV



Caution!

Never connect a fixture which is operating in any stand-alone mode (either Static, Automatic, or Sound-controlled) to a DMX string connected to a DMX controller.

Fixtures in stand-alone mode may transmit DMX signals that could interfere with the DMX signals from the controller.

The Strobe-Override and Blackout modes will override all the other modes and controls. Make sure that they are **not** selected before trying to operate the device in any other mode.

The White Dimmer (**15**) will not be affected in any mode, except for Color Macro Mode. It operates independently from the other operation modes.

Fixtures with amber LEDs will light up in amber when the White Dimmer fader (**15**) is active, regardless of the currently active mode.

For example, even if you press the Cyan button in Chase mode, the amber LEDs will stay on during blackout. Make sure that you set the White Dimmer fader (**15**) to the OFF position, to avoid showing amber when blackout is desired.

1. Color Presets

The 18 preset color buttons **(24)** (Orange, Yellow, Magenta, Cyan, Purple, Full on White, Amber, Peach, Sunflower, Salmon, Lime, Warm White, Sea Foam, Light blue, UV Green, UV Blue, UV Red, UV White) can be used to assign a color to each addressed fixture.

- 01) Select one or more fixtures by pressing the 6 Fixture buttons **(01)**.
- 02) Press the Preset button **(23)**, until the LED indicator lights up.
- 03) Slide the Fade Time fader **(18)** to set the fade time.
- 04) Slide the Master Dimmer fader **(17)** to set the desired light intensity.
- 05) Select one of the 18 Preset Color buttons **(24)**.
- 06) Slide the Strobe Speed fader **(16)** to adjust the strobe intensity.



Sound-Active mode **will not** function in Preset mode.



Color	Fixture 1	Fixture 2	Fixture 3	Fixture 4	Fixture 5	Fixture 6
Red	CH 1,4	CH 7,10	CH 13,16	CH 19,22	CH 25,28	CH 31,34
Yellow	CH 1,2	CH 7,8	CH 13,14	CH 19,20	CH 25,26	CH 31,32
Magenta	CH1,3,4	CH 7,9,10,12	CH 13,15,16,18	CH 19,21,22,24	CH 25,27,28,30	CH 31,33,34,36
Cyan	CH 2,3	CH 8,9	CH 14,15	CH 20,21	CH 26,27	CH 32,33
Purple	CH 1,3,6	CH 7,9,12	CH 13,15,18	CH 19,21,24	CH 25,27,30	CH 31,33,36
Full on	CH 1-6	CH 7-12	CH 13-18	CH 1, 9-24	CH 25-30	CH 31-36
Bamber	CH 4,5	CH 10,11	CH 16,17	CH 22,23	CH 28,29	CH 34,35
Peach	CH 1,4,5	CH 7,10,11	CH 13,16,17	CH 19,22,23	CH 25,28,29	CH 31,34,35
Sun Flower	CH 1,2,4	CH 7,8,10	CH 13,14,16	CH 19,20,22	CH 25,26,28	CH 31,32,34
Salmon	CH 1,4,5	CH 7,10,11	CH 13,16,17	CH 19,22,23	CH 25,28,29	CH 31,34,35
Lime	CH 2,4	CH 8,10	CH 14,16	CH 19,22	CH 26,28	CH 32,34
Warm White	CH 1,2,4,5	CH 7,8,10,11	CH 13,14,16,17	CH 19,20,22,23	CH 25,26,28,29	CH 31,32,34,35
Sea Foam	CH 2,5	CH 8,11	CH 14,17	CH 20,23	CH 26,29	CH 32,35
Light Blue	CH 2,3,6	CH 8,9,12	CH 14,15,18	CH 20,21,24	CH 26,27,30	CH 32,33,36
UV Green	CH 2,6	CH 8,12	CH 14,18	CH 20,24	CH 26,30	CH 32,36
UV Blue	CH 3,6	CH 9,12	CH 15,18	CH 21,24	CH 27,30	CH 33,36
UV Red	CH 1,6	CH 7,12	CH 13,18	CH 19,24	CH 25,30	CH 31,36
UV White	CH 5,6	CH 11,12	CH 17,18	CH 23,24	CH 29,30	CH 35,36

2. Color Fade

This mode will fade all connected devices in unison, as the colors change.

- 01) Select one or more fixtures by pressing the 6 Fixture buttons **(01)**.
- 02) Press the Color Fade button **(02)** until the LED indicator lights up.
- 03) Slide the Speed Time fader **(19)** to set the color change speed.
- 04) Slide the Fade Time fader **(18)** to set the transition time (fade time) between colors.
- 05) Slide the Master Dimmer fader **(17)** to set the desired light intensity.
- 06) Slide the Strobe Speed fader **(16)** to adjust the strobe intensity.



Sound-Active mode **will** function in Auto Fade mode.



3. Auto Mode

This mode uses built-in programs to make the fixtures randomly change colors. The color switch on all fixtures takes place independently.

- 01) Select one or more fixtures by pressing the 6 Fixture buttons **(01)**.
- 02) Press the Auto button **(22)** until the LED indicator lights up.
- 03) Slide the Speed Time fader **(19)** to set the program speed.
- 04) Slide the Fade Time fader **(18)** to set the fade time.
- 05) Slide the Master Dimmer fader **(17)** to set the desired light intensity.
- 06) Slide the Strobe Speed fader **(16)** to adjust the strobe intensity.
- 07) Select one of the 18 Preset Color buttons **(24)**.
- 08) Each fixture (1-6) will now use different random colors.



Sound-Active mode **will** function in Auto Mode.



4. Chase

These preset chases provide several color combinations. The LEDs will go on and off so that the lights appear to be moving along a string.

- 01) Select one or more fixtures by pressing the 6 Fixture buttons **(01)**.
- 02) Press the Chases button **(14)** until the LED indicator lights up.
- 03) Slide the Speed Time fader **(19)** to set the color change speed.
- 04) Slide the Fade Time fader **(18)** to set the transition time (fade time) between colors.
- 05) Slide the Master Dimmer fader **(17)** to set the desired light intensity.
- 06) Press the Preset Colors/Chases buttons **(24)** to select your desired color chase.



Sound-Active mode **will** function in Chase mode.



5. RGB Offset

RGB Offset is a built-in color-fading program that will create a serial chase through fixtures 1-6.

- 01) Press the Color Fade button **(02)** and the Auto button **(22)** at the same time.
- 02) Slide the Speed Time fader **(19)** to set the chase speed.
- 03) Slide the Fade Time fader **(18)** to set the transition time (fade time) between colors.
- 04) Slide the Master Dimmer fader **(17)** to set the desired light intensity.
- 05) Slide the Strobe Speed fader **(16)** to adjust the strobe intensity.



Sound-Active mode **will** function in RGB Offset mode.



6. Color Macro

The preset color macros have variable intensities.

- 01) Select one or more fixtures by pressing the 6 Fixture buttons **(01)**.
- 02) Press the Color Macro button **(03)** until the LED indicator lights up.
- 03) Slide the Speed Time fader **(19)** to select the desired color combination.
- 04) Slide the Fade Time fader **(18)** to set the transition time (fade time) between colors.
- 05) Slide the Master Dimmer fader **(17)** to set the desired light intensity.
- 06) Slide the White Dimmer fader **(15)** to set the desired intensity of the white/amber LEDs.
- 07) Slide the Strobe Speed fader **(16)** to adjust the strobe intensity.
- 08) Color Macro will apply the same color to each fixture.



Sound-Override mode **will not** function while the Color Macro is operating.



7. Sound-Override

This feature will work in Auto Fade, Auto, Chase, and RGB Offset mode and it creates a sound-controlled show, using the selected auto mode. Sound-Override can be triggered by using the microphone instead of the Speed Time fader **(19)**, used for other multi-step modes:

- 01) Press the Sound button **(11)** until the LED indicator lights up.
- 02) Adjust the sound sensitivity by turning the control **(10)**. To increase the sensitivity, turn to the right. To decrease the sensitivity, turn to the left.
- 03) Slide the Strobe Speed fader **(16)** to adjust the strobe intensity.
- 04) The fixture will only respond to the music's low frequencies (bass and drums).



Sound-Active mode **will not** function in Preset mode.



8. Strobe-Override

This mode will produce flashes of light at regular intervals.

- 01) Select one or more fixtures by pressing the 6 Fixture buttons **(01)**.
Note: Strobe-Override will only affect fixtures which are selected.
- 02) Make sure that the color faders are set above 1% for the strobe to function.
- 03) Press the Strobe button **(12)** until the LED indicator lights up.
- 04) Slide the Strobe Speed fader **(16)** to select the strobe speed.
- 05) To cancel this mode for all fixtures at once, double tap the Strobe button **(12)** until the LED indicator goes off.
- 06) To cancel this mode for a single fixture, make sure the Strobe is activated and the Strobe speed fader is set to its minimum level.
- 07) Press the Strobe button **(12)** until the LED indicator is OFF.



When in Strobe-Override Mode, the LED Operator's other operating modes **will not** function.



9. Blackout

When active, this mode darkens the output of all fixtures. The Blackout button **(13)** works in combination with the Fade Time fader **(18)** or as a stand-alone function.

To produce the fading blackout:

- 01) Select one or more fixtures by pressing the 6 Fixture buttons **(01)**.
- 02) Slide the Fade Time fader **(18)** to select how quickly the lights will fade out.
- 03) Press the Blackout button **(13)** until the LED indicator lights up.
- 04) To cancel this mode for a single fixture, make sure that Blackout is active and that Fade Time fader is set to 0.1s (the maximum value).
- 05) Press the Blackout button **(13)** until the LED indicator is OFF. The light output will turn back to its initial state.

10. Manual RGBWAUV

In this mode you can use a custom-made color combination, determined by the position of the Red, Green, Blue, and White faders.

- 01) Press the Manual RGBWAUV button **(21)** until the LED indicator lights up.
- 02) Slide the Speed Time fader (Red), Fade Time fader (Green), Master Dimmer fader (Blue) and Strobe Speed fader (White) **(19, 18, 17, 16)** to manually adjust the color.
- 03) If you need rapid color changes, press and hold down the Red, Green, Blue and Amber buttons **(04, 05, 06, 07)**. When the buttons are pressed, the colors are set to FULL ON. When the buttons are released, the color intensity can again be adjusted with the corresponding faders **(19, 18, 17, 16)**.

- 04) Press the Strobe button **(12)** to add the strobe effect to your light show.
- 05) Slide the Strobe Speed fader **(16)** to adjust the strobe speed.
- 06) Press the Strobe button **(12)** again to deactivate the strobe effect.
The Strobe Speed fader **(16)** will again serve the purpose to adjust the intensity of the white color.



Fading blackout operation does **will not** function in Manual RGBWAUV mode.



Speed/Fade Time functions **will not** function in Manual RGBWAUV mode.

Maintenance

The operator has to make sure that safety-related and machine-technical installations are to be inspected by an expert after every year in the course of an acceptance test.

The operator has to make sure that safety-related and machine-technical installations are to be inspected by a skilled person once a year.

The following points have to be considered during the inspection:

- 01) All screws used for installing the device or parts of the device have to be tightly connected and must not be corroded.
- 02) There may not be any deformations on housings, fixations and installation spots.
- 03) Mechanically moving parts like axles, eyes and others may not show any traces of wearing.
- 04) The electric power supply cables must not show any damages or material fatigue.

The Showtec LED Operator 6 requires almost no maintenance. However, you should keep the unit clean. Disconnect the mains power supply, and then wipe the cover with a damp cloth. Do not immerse in liquid. Do not use alcohol or solvents.

Keep connections clean. Disconnect electric power, and then wipe the DMX and audio connections with a damp cloth. Make sure that the connections are thoroughly dry before linking equipment or supplying electric power.

Troubleshooting

This troubleshooting guide is meant to help solve simple problems.

If a problem occurs, carry out the steps below in sequence until a solution is found. Once the unit operates properly, do not carry out following steps.

No Light

If the LED Operator 6 does not operate properly, refer servicing to a technician.

Suspect two potential problem areas: the power supply, the LEDs.

- 01) Power supply. Check if the unit is plugged into an appropriate power supply.
- 02) The LED Operator 6. Return the LED Operator 6 to your Showtec dealer.
- 03) A LED effect does not respond to the LED Operator 6: Check the DMX address of the fixture and the controller. Make sure that they match. Make sure that the connections are correct.
- 04) Check if blackout is inactive.
- 05) If all of the above appears to be O.K., plug the unit in again.
- 06) If nothing happens after 30 seconds, unplug the device.
- 07) If you are unable to determine the cause of the problem, do not open the LED Operator 6, as this may damage the unit and the warranty will become void.
- 08) Return the device to your Showtec dealer.

No Response to DMX

Suspect the DMX cable or connectors, a controller malfunction, a light effect DMX card malfunction.

- 01) Check the DMX setting. Make sure that DMX addresses are correct.
- 02) Check the DMX cable: Unplug the unit; change the DMX cable; then reconnect to electrical power. Try your DMX control again.
- 03) Determine whether the controller or light effect is at fault. Does the controller operate properly with other DMX fixtures? If not, take the controller in for repair. If so, take the DMX cable and the light effect to a qualified technician.

Product Specifications

Model:	LED Operator 6
Input voltage:	12V DC 500mA
Power consumption:	20W
Dimensions:	393 x 140 x 50 mm (LxWxH)
Weight:	1,7 kg
Operation and Programming	
Signal pin OUT:	pin 1 earth, pin 2 (-), pin 3 (+)
DMX channels:	36 (6 per fixture)
Signal output:	3-pin DMX signal connector OUT
Max. number of supported fixtures	6
Electro-mechanical effects	
RGB presets:	18
Chases:	18
Control Modes:	Color Presets Color Fade Auto Chase RGB Offset Color Macro Sound-Override Strobe-Override Blackout Manual RGBWAUV
Housing:	Grey metal & flame-retardant plastic
Connections:	Power adapter & DMX data connector
Max. ambient temperature t_a :	40°C
Minimum distance:	
Minimum distance to lighted object:	1 m

Design and product specifications are subject to change without prior notice.



Website: www.Showtec.info

Email: service@highlite.nl

Dimensions

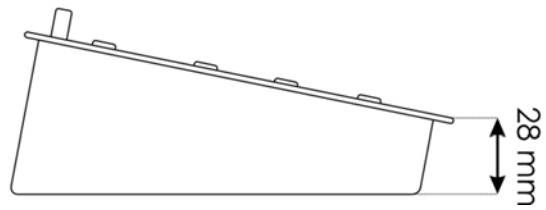
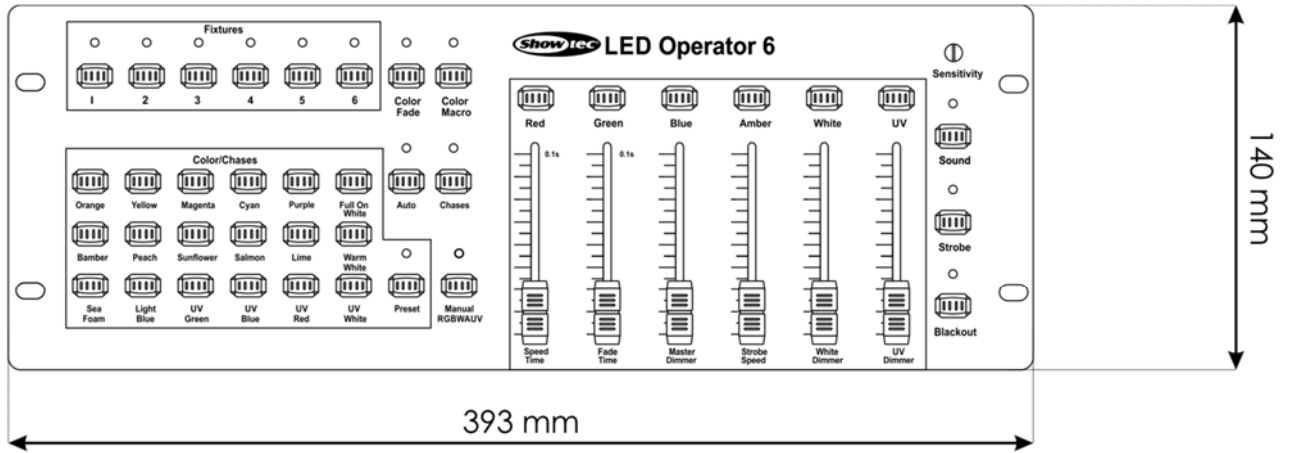



©2017 Showtec