

# elumen8

## Evora 1000 Spot User Manual



Order codes: ELUM023

### WARNING

## FOR YOUR OWN SAFETY, PLEASE READ THIS USER MANUAL CAREFULLY BEFORE YOUR INITIAL START-UP!

- Before your initial start-up, please make sure that there is no damage caused during transportation.
- Should there be any damage, consult your dealer and do not use the equipment.
- To maintain the equipment in good working condition and to ensure safe operation, it is necessary for the user to follow the safety instructions and warning notes written in this manual.
- Please note that damages caused by user modifications to this equipment are not subject to warranty.



### IMPORTANT:

The manufacturer will not accept liability for any resulting damages caused by the non-observance of this manual or any unauthorised modification to the equipment.

- Never let the power cable come into contact with other cables. Handle the power cable and all mains voltage connections with particular caution!
- Never remove warning or informative labels from the unit.
- Do not open the equipment and do not modify the unit.
- Do not connect this equipment to a dimmer pack.
- Do not switch the equipment on and off in short intervals, as this will reduce the system's life.
- Only use the equipment indoors.
- Do not expose to flammable sources, liquids or gases.
- Always disconnect the power from the mains when equipment is not in use or before cleaning! Only handle the power-cable by the plug. Never pull out the plug by pulling the power-cable.
- Make sure that the available mains supply voltage is between 100~240V AC, 50/60Hz.
- Make sure that the power cable is never crimped or damaged. Check the equipment and the power cable periodically.
- If the equipment is dropped or damaged, disconnect the mains power supply immediately and have a qualified engineer inspect the equipment before operating again.
- If the equipment has been exposed to drastic temperature fluctuation (e.g. after transportation), do not connect power or switch it on immediately. The arising condensation might damage the equipment. Leave the equipment switched off until it has reached room temperature.
- If your product fails to function correctly, stop use immediately. Pack the unit securely (preferably in the original packing material), and return it to your Pro Light dealer for service.
- Only use fuses of same type and rating.
- Repairs, servicing and power connection must only be carried out by a qualified technician. THIS UNIT CONTAINS NO USER SERVICEABLE PARTS.
- This lighting fixture is for professional use only - it is not designed for or suitable for household use. The product must be installed by a qualified technician in accordance with local territory regulations. The safety of the installation is the responsibility of the installer. The fixture presents risks of severe injury or death due to fire hazards, electric shock and falls.
- Warning! Risk Group 2 LED product according to EN 62471. Do not view the light output with optical instruments or any device that may concentrate the beam.
- WARRANTY: Two years from date of purchase.

### OPERATING DETERMINATIONS

If this equipment is operated in any other way, than those described in this manual, the product may suffer damage and the warranty becomes void. Incorrect operation may lead to danger e.g: short-circuit, burns and electric shocks etc.

Do not endanger your own safety and the safety of others!

Incorrect installation or use can cause serious damage to people and/or property.

### Evora 1000 Spot

The Evora 1000 Spot features super smooth 3 phase motors and a host of features making this an ideal fixture for larger events and venues. The 180W LED and colour wheel coupled with a 3 facet, indexable rotating prism plus 5 facet linear rotating indexable prism and remote focus produce rich vibrant colours and 2 gobo wheels (9 static and 7 rotating) provide a host of superb animated effects. Pan/tilt auto correction and 16 bit positioning make this fixture perfect for rental and installation alike.

- 1 x 180W white LED
- Beam angle: 12°
- 44,100 Lux @ 2m
- 3.6kHz refresh rate
- Motorised focus
- 3 facet circular rotating indexable prism plus 5 facet linear rotating indexable prism
- Frost filter
- Gobo wheel 1: 7 rotating, indexable, replaceable gobos + open
- Gobo wheel 2: 9 static gobos + open
- Colour wheel: 7 colours + open
- DMX channels: 15
- RDM (Remote Device Management)
- Auto, sound active and master/slave modes
- Pan/tilt auto correction
- 16-Bit pan/tilt positioning
- Pan: 540°, Tilt: 270°
- 0-100% dimming and variable strobe
- Supplied with quick release omega clamps
- 6 push button menu with 1.8" LCD display
- PowerCON input/output
- 3-Pin XLR input/output
- 5-Pin XLR input/output
- Fan cooled



Specifications	Evora 1000 Spot
Power consumption	290W
Fuse	T4A 250V
Power supply	100~240V, 50/60Hz
Dimensions	560 x 390 x 290mm
Weight	16.4kg
Order code	ELUM023

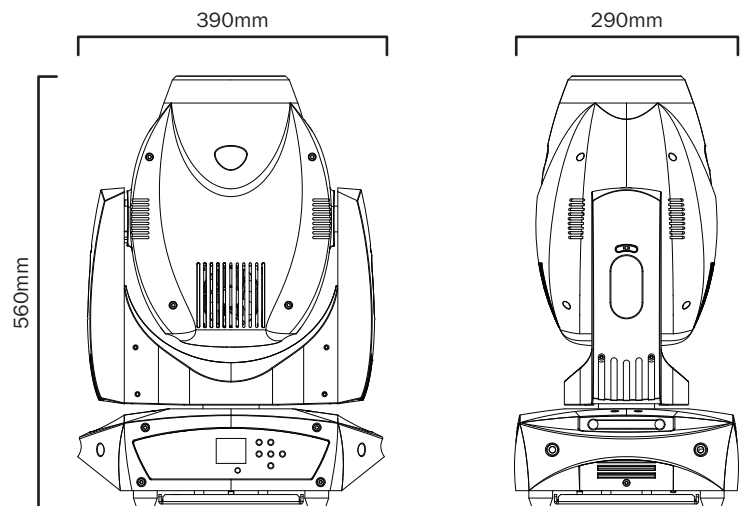
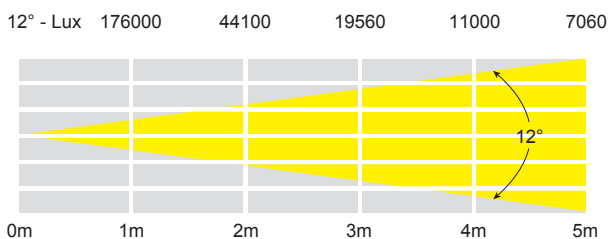

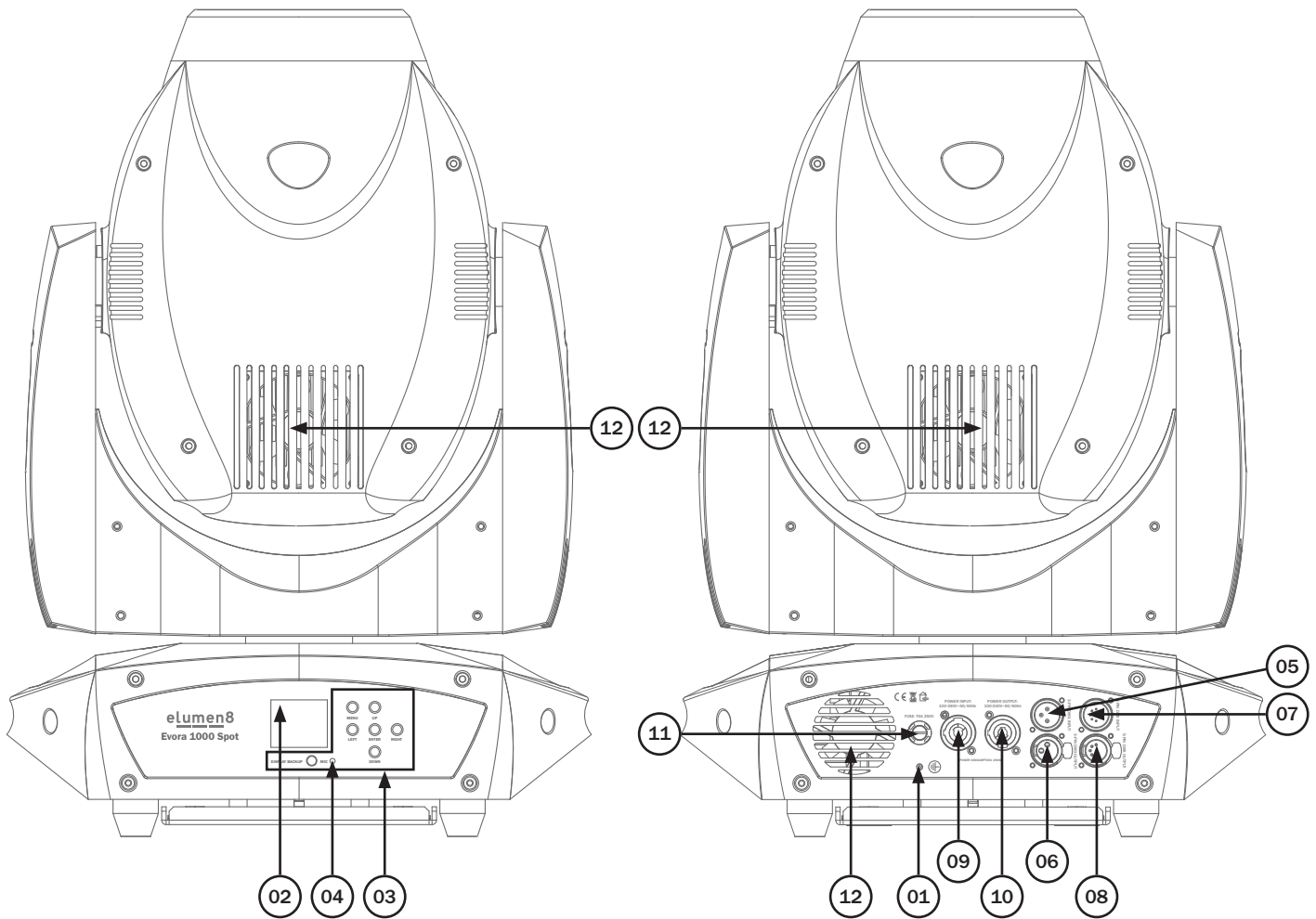

01 - Earth point  
 02 - LCD display  
 03 - Function buttons  
 04 - Microphone

05 - 3-Pin DMX input  
 06 - 3-Pin DMX output  
 07 - 5-Pin DMX input  
 08 - 5-Pin DMX output

09 - PowerCON input  
 10 - PowerCON output  
 11 - Fuse T4A 250V  
 12 - Fans

In the box: **1 x fixture,**  
**2 x omega clamps,**  
**1 x power cable**  
**& 1 x user manual**

### Control Panel Menu:

The LCD control panel situated on the front of the fixture allows the user to access the menu system to adjust the fixtures settings.

When the unit has been powered on it will show “**Software Update Please Wait...**” followed by “**Motor Reset Please Wait...**” and “**eLumen8 Evora 1000 Spot**”. The fixture will then return to its home screen.

Pressing the “**MENU**” button once will take the user to the fixtures main menu. Using the “**UP**” and “**DOWN**” buttons you can then navigate between the different options in the main menu. Pressing the “**ENTER**” button on one of these options allows you to access the sub menu where you can use the “**LEFT**” and “**RIGHT**” buttons to select option/value required. Once the option/value has been selected press the “**ENTER**” button once more to confirm the setting.

To exit out of any of the above options, press and hold the “**MENU**” button.

The LCD control panel can be used via the internal battery. To access this press and hold the “**DISPLAY BACKUP**” button for 5 seconds until the fixtures home screen is displayed. The LCD display will automatically shut off after 20 seconds of inactivity.

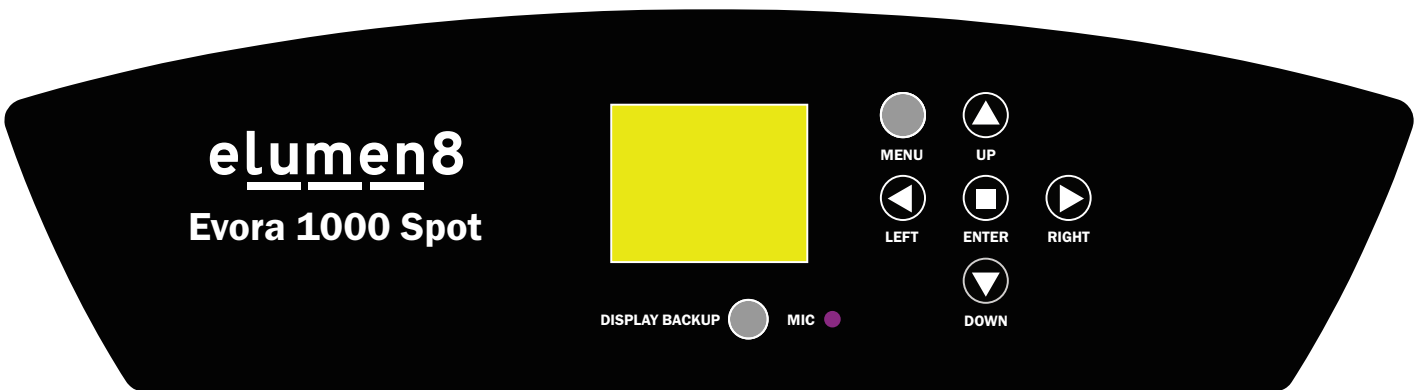

### Error Codes:

When the unit is powered on the unit will automatically perform a motor reset. If there is a problem with one or more of the motors the display will flash 5 times and display “**pan/tilt error**” on the LCD control panel. Please power the unit off and on to reset the motors again.

### Offset Menu:

To access the units offset menu press the “**MENU**” button once to display “**DMX Address**” on the LCD display. Press and hold the “**ENTER**” button until the offset menu is displayed.

Offset Menu	Options/Values (Default Settings in BOLD)	Description
Pan Offset	-128-127 ( <b>000</b> )	Pan Offset
Tilt Offset	-128-127 ( <b>000</b> )	Tilt Offset
Color Offset	-128-127 ( <b>000</b> )	Color Offset
Gobo1 Offset	-128-127 ( <b>000</b> )	Gobo Wheel 1 Offset
RGobo1 Offset	-128-127 ( <b>000</b> )	Gobo Wheel 1 Rotation Offset
Gobo2 Offset	-128-127 ( <b>000</b> )	Gobo Wheel 2 Offset
Prism Offset	000-255 ( <b>000</b> )	Prism Offset
RPrism Offset	-128-127 ( <b>000</b> )	Prism Rotation Offset
Focus Offset	000-255 ( <b>000</b> )	Focus Offset



Main Menu	Sub Menu	Options/Values (Default Settings in BOLD)	Description
DMX Address		<b>001</b> -512	DMX Address Setting
Channel Mode		<b>15Chan</b> (15 channel mode)	DMX Channel Setting
Show Mode		<b>Show 1</b> Show 2 Show 3 Show 4	Show Modes
Split Color		<b>No (AUTO def.)</b> <b>Yes (PRO def.)</b>	Split Colour Setting
Slave Mode		<b>Slave 1 (PRO &amp; AUTO def.)</b> Slave 2	Slave Mode
Black out		<b>No (AUTO def.)</b> <b>Yes (PRO def.)</b>	Blackout
Sound State		<b>On (AUTO def.)</b> <b>Off (PRO def.)</b>	Sound Setting
Sound Sense		000-100 ( <b>090</b> ) (PRO & AUTO def.)	Sound Sensitivity Setting
Pan Inverse		<b>No (PRO &amp; AUTO def.)</b> Yes	Pan Inverse Setting
Tilt Inverse		<b>No (PRO &amp; AUTO def.)</b> Yes	Tilt Inverse Setting
Back Light		<b>On (AUTO def.)</b> <b>Off (PRO def.)</b>	Back Light Setting
Focus Adjust		000-255 ( <b>016</b> )	Gobo Wheel 1 Focus Setting
Focus2 Adjust		000-255 ( <b>061</b> )	Gobo Wheel 2 Focus Setting
FunctionDelay		<b>No Delay (PRO &amp; AUTO def.)</b> 1S Delay 2S Delay 3S Delay	Function Delay Setting
DimmerCalibr.		050- <b>100</b>	Dimmer Calibration
Auto Test		Testing	Auto Test
Temp.		---C	Fixture Temperature
Fixture Time		---h	Fixture Run Time
Firmware Ver.		V0.01J	Software Version
Defaults	<b>No</b> Yes	PRO def. AUTO def.	Default Settings
Reset		<b>No</b> Yes	Motor Reset

## 15 channel mode:

Channel	Value	Function
CH1	000-255	Pan adjustment 0-540°
CH2	000-255	Pan fine adjustment
CH3	000-255	Tilt adjustment 0-270°
CH4	000-255	Tilt fine adjustment
CH5	000-255	Pan/tilt speed
CH6	000-255	Master dimmer (0-100%)
CH7	000-007	LED off
	008-015	LED on
	016-131	Strobe (slow-fast)
	132-139	LED on
	140-181	Strobe ramp up (slow-fast)
	182-189	LED on
	190-231	Strobe ramp down (slow-fast)
	232-239	LED on
	240-247	Random strobe (slow-fast)
	248-255	LED on
CH8 (when split colour is disabled in the menu - see page 6)	000-015	Open (white)
	016-031	Red
	032-047	Orange
	048-063	Green
	064-079	Blue
	080-095	Hot Pink
	096-111	Purple
	112-127	Yellow
	128-189	Colour scroll CW (fast-slow)
	190-193	Colour scroll stop
194-255	Colour scroll CCW (slow-fast)	

Channel	Value	Function
CH8 (when split colour is enabled in the menu - see page 6)	000-007	Open (white)
	008-016	Split colour (Open/Red)
	017-025	Red
	026-033	Split colour (Red/Orange)
	034-042	Orange
	043-050	Split colour (Orange/Green)
	051-059	Green
	060-067	Split colour (Green/Blue)
	068-076	Blue
	077-084	Split colour (Blue/Hot Pink)
	085-093	Hot Pink
	094-101	Split colour (Hot Pink/Purple)
	102-110	Purple
	111-118	Split colour (Purple/Yellow)
	119-127	Yellow
	128-189	Colour scroll CW (fast-slow)
190-193	Colour scroll stop	
194-255	Colour scroll CCW (slow-fast)	
CH9	000-007	Open
	008-015	Rotating gobo 1
	016-023	Rotating gobo 2
	024-031	Rotating gobo 3
	032-039	Rotating gobo 4
	040-047	Rotating gobo 5
	048-055	Rotating gobo 6
	056-063	Rotating gobo 7
	064-072	Gobo 1 shake (slow-fast)
	073-081	Gobo 2 shake (slow-fast)
	082-090	Gobo 3 shake (slow-fast)
	091-099	Gobo 4 shake (slow-fast)
	100-108	Gobo 5 shake (slow-fast)
	109-117	Gobo 6 shake (slow-fast)
	118-127	Gobo 7 shake (slow-fast)
	128-189	Gobo wheel scroll CW (fast-slow)
	190-193	Gobo scroll stop
	194-255	Gobo wheel scroll CCW (slow-fast)

## 15 channel mode cont.:

Channel	Value	Function
CH10	000-127	Gobo rotation index
	128-189	Gobo rotation CW (fast-slow)
	190-193	Rotation stop
	194-255	Gobo rotation CCW (slow-fast)
CH11	000-007	Open
	008-015	Static gobo 1
	016-023	Static gobo 2
	024-031	Static gobo 3
	032-039	Static gobo 4
	040-047	Static gobo 5
	048-055	Static gobo 6
	056-063	Static gobo 7
	064-072	Gobo 1 shake (slow-fast)
	073-081	Gobo 2 shake (slow-fast)
	082-090	Gobo 3 shake (slow-fast)
	091-099	Gobo 4 shake (slow-fast)
	100-108	Gobo 5 shake (slow-fast)
	109-117	Gobo 6 shake (slow-fast)
	118-127	Gobo 7 shake (slow-fast)
	128-189	Gobo wheel scroll CW (fast-slow)
	190-193	Gobo scroll stop
	194-255	Gobo wheel scroll CCW (slow-fast)
CH12	000-006	Open
	007-088	3 facet prism
	089-172	5 facet prism
	173-255	Frost filter
CH13	000-127	Prism indexing
	128-189	Prism rotation CCW (fast-slow)
	190-193	Prism rotation stop
	194-255	Prism rotation CW (slow-fast)
CH14	000-255	Focus

Channel	Value	Function
CH15	000-069	Disable all
	070-079	Enable blackout whilst pan/tilt
	080-089	Disable blackout whilst pan/tilt
	090-099	Enable blackout whilst colour changing
	100-109	Disable blackout whilst colour changing
	110-119	Enable blackout whilst gobo changing
	120-129	Disable blackout whilst gobo changing
	130-199	No function
	200-209	Reset motors
	210-249	No function
	250-255	Sound active (CH6 and CH7 must be at 255)



Rotating gobos:

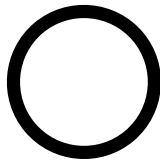

Open

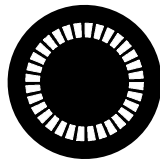

Gobo 1



Gobo 2

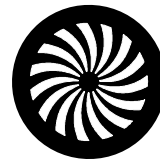

Gobo 3



Gobo 4



Gobo 5



Gobo 6

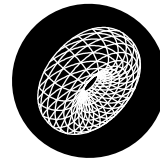

Gobo 7

Static gobos:

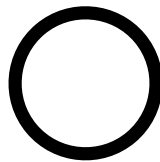

Open

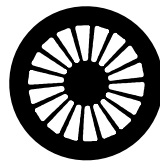

Gobo 1

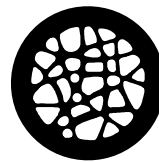

Gobo 2

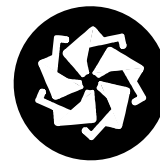

Gobo 3

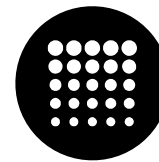

Gobo 4



Gobo 5

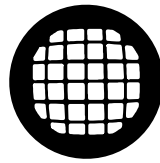

Gobo 6



Gobo 7



Gobo 8



Gobo 9

### Setting the DMX address:

The DMX mode enables the use of a universal DMX controller. Each fixture requires a “start address” from 1- 511. A fixture requiring one or more channels for control begins to read the data on the channel indicated by the start address. For example, a fixture that occupies or uses 7 channels of DMX and was addressed to start on DMX channel 100, would read data from channels: 100,101,102,103,104,105 and 106. Choose a start address so that the channels used do not overlap. E.g. the next unit in the chain starts at 107.

### DMX 512:

DMX (Digital Multiplex) is a universal protocol used as a form of communication between intelligent fixtures and controllers. A DMX controller sends DMX data instructions from the controller to the fixture. DMX data is sent as serial data that travels from fixture to fixture via the DATA “IN” and DATA “OUT” XLR terminals located on all DMX fixtures (most controllers only have a data “out” terminal).

### DMX linking:

DMX is a language allowing all makes and models of different manufactures to be linked together and operate from a single controller, as long as all fixtures and the controller are DMX compliant. To ensure proper DMX data transmission, when using several DMX fixtures try to use the shortest cable path possible. The order in which fixtures are connected in a DMX line does not influence the DMX addressing. For example; a fixture assigned to a DMX address of 1 may be placed anywhere in a DMX line, at the beginning, at the end, or anywhere in the middle. When a fixture is assigned a DMX address of 1, the DMX controller knows to send DATA assigned to address 1 to that unit, no matter where it is located in the DMX chain.

### DATA cable (DMX cable) requirements (for DMX operation):

This fixture can be controlled via DMX-512 protocol. The DMX address is set on the back of the unit. Your unit and your DMX controller require a standard 3-pin XLR connector for data input/output, see image below.



Further DMX cables can be purchased from all good sound and lighting suppliers or Pro Light Concepts dealers.

Please quote:

**CABL10 – 2m**

**CABL11 – 5m**

**CABL12 – 10m**

**Note: DMX cable must be daisy chained and cannot be split.**

**Notice:**

Be sure to follow the diagrams below when making your own cables. Do not connect the cables shield conductor to the ground lug or allow the shield conductor to come in contact with the XLRs outer casing. Grounding the shield could cause a short circuit and erratic behaviour.

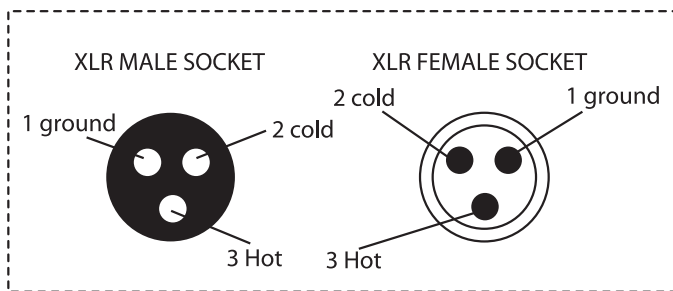
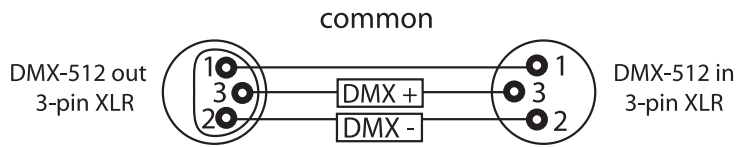

XLR Pin Configuration
Pin 1 = Ground
Pin 2 = Negative
Pin 3 = Postive

**Special note:**

**Line termination:**

When longer runs of cable are used, you may need to use a terminator on the last unit to avoid erratic behaviour.

**Using a cable terminator will decrease the possibilities of erratic behaviour.**

**(3-pin - Order ref: CABL90, 5-pin - Order ref: CABL89)**

Termination reduces signal transmission problems and interference. It is always advisable to connect a DMX terminal, (resistance 120 Ohm 1/4 W) between pin 2 (DMX-) and pin 3 (DMX+) of the last fixture.

**5-pin XLR DMX connectors:**

Some manufactures use 5-pin XLR connectors for data transmission in place of 3-pin. 5-pin XLR fixtures may be implemented in a 3-pin XLR DMX line. When inserting standard 5-pin XLR connectors in to a 3-pin line a cable adaptor must be used. The diagram below details the correct cable conversion.

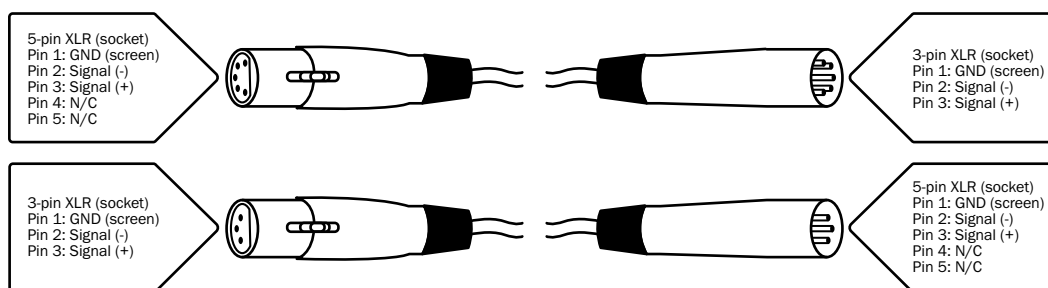



***Correct Disposal of this Product  
(Waste Electrical & Electronic Equipment)***

**(Applicable in the European Union and other European countries  
with separate collection systems)**

This marking shown on the product or its literature, indicates that it should not be disposed with other household wastes at the end of its working life. To prevent possible harm to the environment or human health from uncontrolled waste disposal, please separate this from other types of wastes and recycle it responsibly to promote the sustainable reuse of material resources.

Household users should contact either the retailer where they purchased this product, or their local government office, for details of where and how they can take this item for environmentally safe recycling.

Business users should contact their supplier and check the terms and conditions of the purchase contract. This product should not be mixed with other commercial wastes for disposal.

