

■ Technical data COBOPIN-VT3001C-I

Panels/Output.....	1 panel, 540 lm
LED configuration.....	1x20W COB-TriLED (1x5W-R, 1x7W-G, 1x7W-B)
Optics.....	Secondary, 30 degrees
DMX Control & protocol.....	3-5 Channels DMX 512 (1990)
IP Rating.....	20 (indoor)
Mains Input.....	AC100-250V~ 50/60Hz
Power supply type, max. consumption.....	switch mode, 29W
DMX connections.....	3 pin XLR (Male / Female)
Modulation Type.....	Pulse Density Modulation (PDM)
Dimensions (without bracket) WxHxD.....	100.0 x 99.0 x 202.0mm
Dimensions (with bracket) WxHxD.....	115.0 x 213.0 x 202.0mm
Weight.....	1.5kg

Technical data COBOPIN-VT3001C-T

Panels/Output.....	1 panel, 540 lm
LED configuration.....	1x20W COB-TriLED (1x5W-R, 1x7W-G, 1x7W-B)
Optics.....	Secondary, 30 degrees
DMX Control & protocol.....	3-5 Channels DMX 512 (1990)
IP Rating.....	20 (indoor)
Mains Input.....	AC100-250V~ 50/60Hz
Power supply type, max. consumption.....	switch mode, 29W
DMX connections.....	3 pin XLR (Male / Female)
Modulation Type.....	Pulse Density Modulation (PDM)
Dimensions (without bracket) WxHxD.....	100.0 x 99.0 x 202.0mm
Dimensions (with bracket) WxHxD.....	151.0 x 213.0 x 202.0mm
Weight.....	1.6kg

■ Standards

This product complies with the following standards:

EU electrical safety.....	EN60598-1:2008, EN60598-2-1:1989
EU general safety.....	EN60598-2-17
EU photobiological safety.....	EN 62471:2008
EU EMC.....	EN55015: 2006 + A1:2007, EN61547:1995 + A1:2000
EU Harmonics.....	EN61000-3-2:2006
EU Flicker.....	EN61000-3-3:2008
US safety.....	UL60065
US EMC.....	FCC Part 15

This product meets both the EMC Directive 2004/108/EC and the Low Voltage Directive 2006/95/EC.

Ask your dealer or visit www.multiform-lighting.com for more information.

USER MANUAL

COBOPIN-VT3001C(-I/-T)

High-Power RGB LED Lighting Fixture

For firmware 50-010-0018-00111-1-00 (RevL)

ENGLISH Page 2-16



Updated versions of this document may be available at WWW.MULTIFORM-LIGHTING.COM

RevA 10/2013 Order code: 12-010-0403-80101-1-01

■ Introduction

Dear customer,

congratulations on the purchase of a Multiform-branded item and the trust having been put in us with this decision. Multiform is one of the leading global manufacturers of professional lighting equipment and has decades of experience in design, production and quality assurance.

To meet your requirements, this unit has been designed and built to the highest standards, so that we can assure you that you have made a good and satisfying investment. To take full advantage of all possibilities and for your own safety and the safety of your environment, please read these operating instructions carefully before you start using the unit.

■ Description

The CoboPin-VT3001C is a powerful yet compact RGB color-mixing light fixture for indoor applications, which range from architectural purposes to stage lighting. With its compact design, high-efficiency drive electronics and advanced cooling system, this fixture has been designed for both flexibility and reliability. It is available in a single-bracket version for installation purposes (VT-3001C-I) and a dual-bracket version for touring applications (VT3001C-T).

SAFETY INFORMATION



Read the safety precautions in this chapter before installing, powering up, operating or servicing this device. Failure to do so may void the product warranty, and releases the manufacturer from all product liability.

■ Symbols used in this manual

The following symbols are used to identify important safety information on the product and in this manual:



WARNING! Read manual before installation, operation or servicing.



WARNING! Safety hazard. Risk of injury or death.



WARNING! Hazardous voltage. Risk of severe or fatal electric shock.

mix mode. Otherwise you will be in pattern mode. In this mode the potentiometer (1) is disabled.

Display on/off

If none of the buttons is pressed for more than approximately 25 seconds the display is switched off. As soon as one of the buttons is pressed again, the display switches on immediately.

Key lock

Pressing the MODE button (7) for longer than 3 seconds locks all the buttons (5-7) and the potentiometer (1). The display shows “LOC” in alteration to the mode (changing every 2 seconds). Pressing the MODE button again for more than 3 seconds unlocks the button- and potentiometer-functions. Please note: If the display is in OFF-mode it will take approximately 25 seconds before the display switches off. It will be switched on again if any key is touched and will switch off again after 25 seconds if the keys are not unlocked by the procedure mentioned above.

Switch on condition

The unit always returns to the last mode before it was switched off; in DMX modes however DMX values are cleared if power is switched off.

DMX signal drop condition

The device will retain the status that it was in before the DMX signal got lost, but potential tact settings will be automatically cleared.

■ Maintenance

This unit does not need regular maintenance. The internal circuit is protected by a 250V/2A slow-blow fuse 5x20mm fuse. If this fuse fails, this usually indicates an internal fault requiring servicing by a qualified engineer.

The unit receives DMX values on a packet of four channels and mirrors the received data on the DMX output (9). If a DMX signal is present the DMX LED (3) will turn on. The four channels control the unit as follows:

If DMX-value of channel 3 is **lower than 50** the unit works with static colours:

DMX Channel	Value Range	Function
CH1	000-255	Output mix choice from presets (see "C" mode)
CH2	000-255	Master level
CH3	000-049	Static mix mode active
CH4	000-049	Tact off
	050-255	Tact (050=slow / 255=max. speed 23 Hz)

Output mix presets can be activated by means of CH1 whilst the chosen mix can be adjusted with CH2. If the value of CH4 is above 50 the unit is set to tact mode. The tact speed for any fixed output mix chosen on the first channel can be adjusted from zero (value <50) to 23 cycles per second (value 255).

If DMX value of channel 3 is **equal or higher than 50** the unit works in pattern mode:

CH1	Pattern	CH1	Pattern
000-015	Soft fade red-green	136-150	Hard switch green-blue
016-030	Soft fade green-blue	151-165	Hard switch red-blue
031-045	Soft fade red-blue	166-180	Hard switch red-yellow
046-060	Soft fade red-yellow	181-195	Hard switch candy-lime
061-075	Soft fade candy-lime	196-210	Hard switch pink-blue
076-090	Soft fade pink-blue	211-225	Hard switch turquoise-pink
091-105	Soft fade turquoise-pink	226-240	Hard switch red-green-blue
106-120	Soft fade red-green-blue (RGB)	241-255	Hard switch red-yellow-green-
121-135	Hard switch red-green		turquoise-blue-pink

DMX	Value range	Function
CH2	000-255	Level
CH3	050-255	Chase speed
CH4	000-049	Tact off
	050-255	Tact (050=slow / 255=max. speed 23 Hz)

The pre-programmed soft fade or hard switching patterns can be chosen by means of CH1 whilst CH2 is used as a level channel. CH3 allows to set the fade time or pattern speed from slow (value 50) to very fast (value 255). If channel 4 reaches a DMX value of 50 or above a tact function will be added to the chases. The tact speed can be adjusted from slow (value 50) to 23 pulses per second (value 255).

Note: Whether the unit works in static mix mode or pattern mode only depends on the value of channel 3. So make sure the value of channel 3 is lower than 50 to be in static



WARNING! Shock hazard. Equipment must be properly grounded.



WARNING! Hot surface. Risk of skin burn or skin irritation.



WARNING! Fire hazard.



WARNING! Laser radiation. Risk of surface damage.



WARNING! LED light emission. Risk of eye injury.

■ **Security advice before use**



General advice:

1. Read this manual completely before using the product.
2. Keep this manual in your records for future reference.
3. Follow all instruction printed in this manual.
4. Follow all printed security advice on the product itself.
5. Take care of enough distance between this product and sources of hum and noise like electric motors and transformers.
6. Carry this product with greatest care. Punches, big forces and heavy vibration may damage this product mechanically.



Protection from eye injury

1. Warning: Depending on the configuration of the device, this device may reach or exceed the limits of EN62471, risk group 2, and may hence reach to risk group 3.
2. To avoid eye injury, do not look into the beam from a distance of less than 8.5 m (27 ft. 11 ins) from the front surface of the fixture without protective eyewear such as shade-5 welding goggles. At larger distances, light output is harmless to the naked eye provided that the eye's natural aversion response is not affected.
3. Do not view the beam directly with optical instruments such as magnifiers, telescopes, binoculars or similar optical instruments that may concentrate the light output.
4. Ensure that during setup and DMX programming, no persons are inside a 8.50m (27 ft. 11 ins) vicinity of the device's front surface, to avoid that they may accidentally be exposed to the light beam.



Protection from electric shock:

1. Only connect this unit to a mains socket outlet with protective earth connection, ground-fault (earth-fault) and overload protection.
2. Where the mains plug or an appliance coupler is used as a disconnect device, such device shall remain readily operable.
3. To pull the AC Cord out of the wall outlet or the unit's AC socket, never pull the cable itself, but only the AC plug.
4. Disconnect the unit from AC supply before any kind of cleaning on the product. Use smooth and dry cloth only for cleaning.
5. Do not expose this unit to any dripping or splashing liquids, and do not place objects filled with liquids, such as vases, on the unit.
6. Do not operate this unit near to open water or in high humidity.
7. Choose the position of the AC cord according to the lowest risk of damage by foot steps or by squeezing it.
8. Do not open the unit for service, there are no user-serviceable parts inside. Warranty will be void in any case of unauthorized service by the user or other not authorized persons.



Protection from fire:

1. Take care of not placing the unit near sources of heat (e.g. powerful amplifiers, fog machines).
2. Allow at least about 0.15m (6 ins.) between this unit and other devices or a wall to allow for proper cooling.
3. Take always care of sufficient air convection in the unit's environment to avoid overheating. Make sure air convection slots are not blocked. Do not operate this unit in environmental temperatures exceeding 40 degrees Celsius.
4. Be sure this fixture is kept at least 0.75m (30ins.) away from any flammable materials (decoration etc.).
5. Do not stick filters, masks or other materials directly on the LEDs or the LED cover screen.
6. Check the total maximum power of your AC wall outlet if you connect several units to one wall outlet and avoid any overloading.
7. If the device itself has an AC outlet for providing power to other units, make sure to not exceed the specified maximum load.



Protection from injury and damage:

1. Never use any accessories or modifications not authorized by the manufacturer of this unit.
2. Choose a location for operation where the unit is protected from vibration and where a fixed mounting position is provided. In case of overhead-mounting, follow applicable rigging requirements.
3. Before plugging the AC cord in the wall outlet, check whether the AC plug, the mains voltage and frequency are the same as this product is specified for. If not, contact you dealer immediately.

The unit receives DMX values on a packet of four channels and mirrors the received data on the DMX output (9). If a DMX signal is present the DMX LED (3) will turn on. The four channels control the unit as follows:

DMX channel	Value Range	Function
CH1	000-255	Red intensity
CH2	000-255	Green intensity
CH3	000-255	Blue intensity
CH4	000-127	Master dimmer
	128-227	Strobe (128=slow / 227=max. speed 23 Hz)
	228-255	Master dimmer full on, Strobe off

This setting is stored even if the device is switched off.

“d5” Mode (DMX 5-Channel Split Master/Strobe Mode)

Press the MODE button (7) until the display shows “d5”, indicating operation in “d” (DMX) mode. Shortly after that, the display shows the DMX starting address. You can choose any DMX starting address by simply using the UP/DOWN buttons (5/6). The chosen DMX-address comes effective approximately 3 seconds later and will show up on the display (2) in alternation to the “d”. This allows control of the unit by any external DMX signal sending on the chosen channel. In this mode the potentiometer (1) is disabled.

The unit receives DMX values on a packet of five channels and mirrors the received data on the DMX output (9). If a DMX signal is present the DMX LED (3) will turn on. The five channels control the unit as follows:

DMX channel	Value Range	Function
CH1	000-255	Red Intensity
CH2	000-255	Green intensity
CH3	000-255	Blue intensity
CH4	000-255	Master dimmer
CH5	000-255	000...049 Strobe off, 050...255 Strobe rate (050=slow / 255=max. speed 23 Hz)

This setting is stored even if the device is switched off.

“P” DMX Preset Mode

If you want to run the pre-programmed patterns and scenes by an external DMX-controller you can use the DMX Preset Mode. Press the MODE button (7) until the display shows “dP”, indicating operation in “P” (DMX Preset) mode. Set the DMX starting address by simply using the UP/DOWN buttons (5/6). The chosen DMX-address comes effective approximately 3 seconds later and will show up on the display (2) in alternation to the “dP”.

Available colour presets:

C 0	all off	C10	Frog
C 1	Red	C11	Lavender
C 2	Green	C12	Candy
C 3	Blue	C13	Peach
C 4	Yellow	C14	Aqua
C 5	Pink	C15	Leaf
C 6	Turquoise	C16	Purple
C 7	Lime	C17	Barbie
C 8	Orange	C18	Breeze
C 9	Marine	C19	White

“d3” Mode (DMX 3-Channel RAW Mode)

Press the MODE button (7) until the display shows “d3”, indicating operation in “d3” (3-channel DMX) mode. Shortly after that, the display shows the DMX starting address. You can choose any DMX starting address by simply using the UP/DOWN buttons (5/6). The chosen DMX-address comes effective approximately 3 seconds later and will show up on the display (2) in alternation to the “d”. This allows control of the unit by any external DMX signal sending on the chosen channel. In this mode the potentiometer (1) is disabled.

The unit receives DMX values on a packet of three channels and mirrors the received data on the DMX output (9). If a DMX signal is present the DMX LED (3) will turn on. The three channels control the unit as follows:

DMX channel	Value Range	Function
CH1	000-255	Red Intensity
CH2	000-255	Green Intensity
CH3	000-255	Blue Intensity

This setting is stored even if the device is switched off.

Note: For master/slave operation, the slave units shall be set to “d3” mode.

“d4” Mode (DMX 4-Channel Combined Master/Strobe Mode)

Press the MODE button (7) until the display shows “d4”, indicating operation in “d4” (4-Channel DMX) mode. Shortly after that, the display shows the DMX starting address. You can choose any DMX starting address by simply using the UP/DOWN buttons (5/6). The chosen DMX-address comes effective approximately 3 seconds later and will show up on the display (2) in alternation to the “d”. This allows control of the unit by any external DMX signal sending on the chosen channel. In this mode the potentiometer (1) is disabled.

- The surface of the device may get hot during operation, and heat sink areas may reach to or exceed the limits of EN60950. Do not touch heat sink areas of the device during operation, and allow 20 minutes of cool-down time after powering off before touching.
- If fluids have spilled into the unit or small parts have intruded the unit, immediately switch off the unit and hand it over to the authorized service for a security check.
- Disconnect the unit from AC supply by pulling the AC plug out of the wall outlet or the unit's AC socket during a thunder-storm in order to avoid any damage on the unit due to AC voltage peaks.
- In case of not correct function of this unit or damaged AC cord or other damaged parts, pull immediately the AC plug out of the wall outlet and hand the unit over to the authorized service for a security check.
- To meet all aspects of functionality and security during maintenance work to be preformed on this unit, all parts should be replaced by genuine spare parts. Consequently, take care of your dealer or maintenance company to be authorized by the manufacturer.

■ Health advice

This unit produces and absorbs electromagnetic radiation. The strength of radiation and the sensitivity for disturbing interference matches the CE and FCC requirements. A corresponding sign is printed on the backside of the unit. Any change or modification may affect the behavior of the unit concerning electromagnetic radiation, with the CE requirements eventually not to be met any more. The manufacturer takes no responsibility in this case.

■ Functional advice

This unit is immune to the presence of electromagnetic disturbances – both conducted and radiated - up to a certain level. Under peak conditions, the unit is classified to show a “class C” performance criteria and may encounter temporary degradation or loss of function which may need manual help to recover. In such case, disconnect the AC power from the unit and reconnect it again to recover.

■ Environmental advice



This unit is built to conform to the ROHS standards and the WEEE directive 2002/96/EC of the European Parliament and of the Council of the European Union. Under these regulations, the product shall not be discarded into regular garbage at the end of its life, but shall be returned to authorized recycling stations.

■ LED Lifetime advice

LED lifetime is determined by the gradually declining brightness of a LED over time, with a point of 50% brightness reduction marking the defined end of its lifetime. The driving factor of this effect is the heat that the chip inside the LED is exposed to. While a chip may under ideal circumstances reach to more than 100000 hours of lifetime, the real-world lifetime may only be 30000 to 50000 hours or less if the LED is exposed to excessive heat, which can be caused by continuously running all LEDs inside this device at full power and operating the unit in high environmental temperatures. If improving the lifespan expectancy is a priority, take care of providing for lower operational temperatures. This may include forced external cooling and/or the reduction of overall projection intensity.

■ Unpacking

Please check that the box contains the following items, and contact your dealer immediately for replacement if any part is missing:

Main parts: 1 pc. CoboPin-VT3001C fixture
 1 pc. Power cord
 1 pc. Operation manual

■ Getting started: choosing a location



Risk of fire: The CoboPin-VT3001C has been designed to work in dry indoor environments at environmental temperatures up to 35 degrees Celsius. For proper operation, the unit must be operated with its heatsink side of the power supply up, and unobstructed air convection to the heatsink.

Note:

- Do not operate the CoboPin-VT3001C in environments with more than 35 degrees environmental temperature or more than 75% relative humidity.
- Do not operate the CoboPin-VT3001C in any position inclined or reclined more than 45 degrees from being upright (heatsink on top).
- Do not operate the CoboPin-VT3001C in any closed environment smaller than 10cbm, unless forced air convection is provided.

#	Description	Function of Knob (1)
A 0	All off	none
A 1	Static scene	Colour
A 2	Soft fade red-green	Speed
A 3	Soft fade green-blue	Speed
A 4	Soft fade red-blue	Speed
A 5	Soft fade red-yellow	Speed
A 6	Soft fade candy-lime	Speed
A 7	Soft fade pink-blue	Speed
A 8	Soft fade turquoise-pink	Speed
A 9	Soft fade red-green-blue (RGB)	Speed
A10	Hard switch red-green	Sound-to-light, Speed
A11	Hard switch green-blue	Sound-to-light, Speed
A12	Hard switch red-blue	Sound-to-light, Speed
A13	Hard switch red-yellow	Sound-to-light, Speed
A14	Hard switch candy-lime	Sound-to-light, Speed
A15	Hard switch pink-blue	Sound-to-light, Speed
A16	Hard switch turquoise-pink	Sound-to-light, Speed
A17	Hard switch red-green-blue	Sound-to-light, Speed
A18	Hard switch red-yellow-green-turquoise-blue-pink	Sound-to-light, Speed
A19	Random speed red-yellow (Fire)	Base speed
A20	Random speed green-blue (Ocean)	Base speed
A21	Random speed red-blue (Plush)	Base speed
A22	Random speed red-green-blue (RGB Burst)	Base speed
A23	White strobe	Sound-to-light, Speed
A24	Red strobe	Sound-to-light, Speed
A25	Green strobe	Sound-to-light, Speed
A26	Blue strobe	Sound-to-light, Speed
A27	Strobe chase red-green-blue	Sound-to-light, Speed

“C” Colour Mode

Press the MODE button (7) until the first digit on the display shows “C”, indicating operation in “C” mode. Then choose by using the UP/DOWN buttons (5/6) one of the 19 presets as shown in the list below. Changing the setting becomes effective directly. Knob (1) determines the output level.

In “C” mode, the unit does not receive any values from the DMX input but generates related DMX values on the output according to the selected pattern, so that other similar units can show the same behaviour if they are connected by DMX signal cables and set to mode “d3”.

NOTE: The “C” Mode is automatically disabled and cannot be chosen when an external DMX signal is received [DMX indicator LED (3) is lit].

If you leave mode “C” for any reason and come back later into mode “C”, the unit will recall the last chosen mix (even if the unit was switched off in between).

User interface overview:

- 1 In A-Mode: Speed Control (except A1 = Mix Control)
In C-Mode: Level-Control
- 2 Display showing the Mode, DMX-address, LOC-function etc.
- 3 Indicates presence of a DMX signal
- 4 Indicates the sound-activated mode (internal microphone)
- 5 DOWN-button
- 6 UP-button
- 7 MODE selection button
- 8 DMX-Input connector
- 9 DMX-Output connector
- 10 AC Power Output
- 11 AC Power Input

Upon the user's choice, the unit can work stand-alone or may be controlled by external DMX-controllers. Available modes:

“A” Auto Mode

Press the MODE button (7) until the first digit on the display shows “A”, indicating operation in “A” (AUTO) mode. Then choose your desired pattern by using the UP/DOWN buttons (5/6), see list below. Changing the setting becomes effective 1 second after the new setting is made to allow stepping through presets without previewing all intermediate presets.

NOTE: The “A” Mode is automatically disabled and cannot be chosen when an external DMX signal is received [DMX indicator LED (3) is lit].

Whilst being in pattern A 1 (static scene), turning knob (1) determines the mix, whereas being in one of the other 26 patterns, knob (1) controls the speed or selects the sound-activated function (refer to below pattern list). The sound-activated function can be activated by setting the knob (1) inside the first 10 degrees of its travel from left detent and it works from a built-in microphone which picks up the environmental sound. Its activity is shown by the flashing of the right dot (4) in the display. The level for all patterns is maximum.

In “A” mode, the unit does not receive any values from the DMX input, but generates related DMX values on the output according to the selected pattern, so that other similar units can show the same pattern if they are connected by DMX signal cables and set to mode “d3”.

If you leave mode “A” for any reason and come back later into mode “A”, the unit will recall the last chosen pattern (even if the unit was switched off in between). Pattern list:

■ Getting started: secure mounting

The CoboPin-VT3001C can be positioned for operation in various ways:

Floor standing operation (only –T touring version)

- Turn the bracket to the lower side of the unit
- Separate the two split bracket to provide suitable ground support
- Place the unit in a secure position where it can neither be touched by anyone or could possibly become an objective for anyone to stumble.
- Make sure to comply with cooling requirements of the used power supply if any.

Hanging/Rigging, ceiling-mounted operation

Risk of injury: Overhead mounting requires extensive experience, like calculating working load limits, knowledge installation materials, and periodic safety inspection of all installation material and the unit. If you lack such qualifications, do not attempt the installation yourself. Improper installation can result in body injury. Be sure to complete all rigging and installation procedures before applying power to the unit.

- Leave the inner and outer bracket folded.
- The unit should be installed out of reach of people and outside areas where persons may walk by or be seated.
- Make sure that the installation area can hold a minimum point load of 10 times the device's weight.
- In fixed installations, fix the unit with self-locking screws/nuts to the mounting point.
- When mounting the unit to truss be sure to secure an appropriately rated clamp to the hanging yoke using a M10 screw fitted through the center hole of the hanging yoke.
- Where required, secure the installation with an appropriate safety cable. Always use a certified safety cable according to DIN56927 that can hold 12 times the weight of the device when installing the unit. This secondary safety attachment should be installed in a way that no part of the installation can drop more than 20cm if the main attachment fails.
- Never stand directly below the device when mounting, removing, or servicing the fixture. Make sure the area below the installation place is free from unwanted persons during rigging, de-rigging and servicing.
- The operator has to make sure that the safety-relating and machine-technical installations are approved by an expert before using them for the first time. The installations should be re-inspected every year.
- Make sure to comply with applicable cooling requirements if any.

■ Getting started: making AC supply connections



Risk of fire / Safety risk

The CoboPin-VT3001C requires an AC power source with sufficient power carriage and correct grounding to ensure safe operation. The AC power source must be equipped with a circuit breaker and earth leakage detector. Make sure to only use compliant AC supply lines.

■ Getting started: making DMX control connections

Connect the CoboPin-VT3001C to a suitable DMX controller where needed, and interconnect several units by means of their DMX In/Outputs as required. The last unit shall be equipped with a proper 120 Ohm termination resistor equipped DMX-plug as shown in below drawing. Please make sure that all used DMX cables comply to below standard:

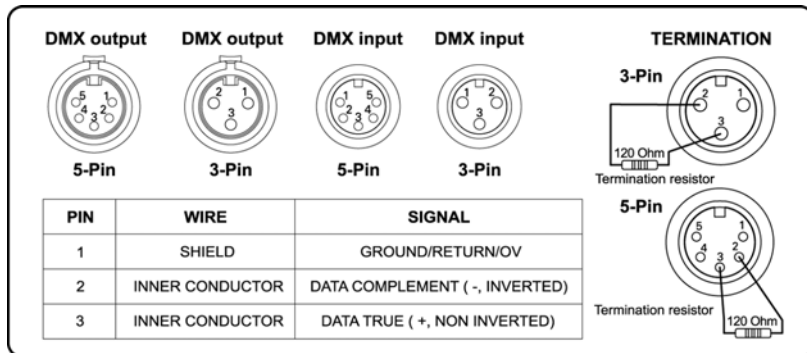

■ Operation

VT3001-I (install version)

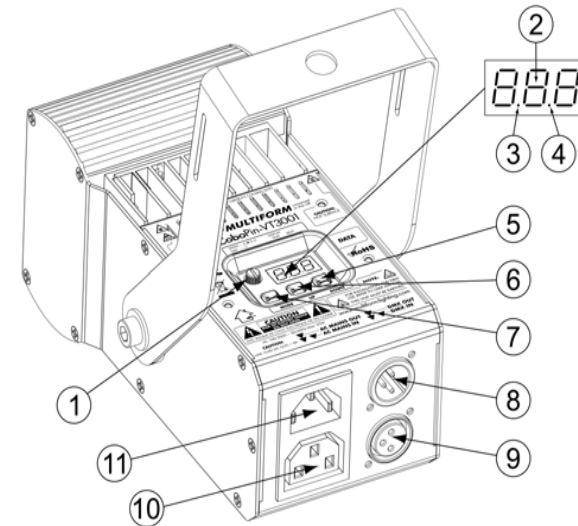

VT3001-T (touring version)

