

# USER MANUAL

RevA 06-2013

# ZPR-2820

2-ZONE PREAMP-MIXER

## Welcome

Thank you for choosing Hill Audio for your sound system. To make sure that this product meets your expectations and provides long-term, reliable performance, please read and follow this instruction manual carefully.

## Manual Language

UK	This user manual is written in English. For other languages, visit	<a href="http://www.hill-audio.com">www.hill-audio.com</a>
FR	Ce guide est écrit en anglais. Pour les autres langues, visitez:	<a href="http://www.hill-audio.com">www.hill-audio.com</a>
DE	Diese Anleitung ist in Englisch verfasst. Für andere Sprachen:	<a href="http://www.hill-audio.com">www.hill-audio.com</a>
ES	Este manual está escrito en Inglés. Para otros idiomas, visite:	<a href="http://www.hill-audio.com">www.hill-audio.com</a>
PT	Este manual está escrito em Inglês. Para outros idiomas, visite:	<a href="http://www.hill-audio.com">www.hill-audio.com</a>
IT	Questo manuale è scritto in inglese. Per altre lingue, visitare:	<a href="http://www.hill-audio.com">www.hill-audio.com</a>

## Important safety instructions

- Read these instructions and all markings on the product. Keep these instructions.
- Heed all warnings and instructions, both in this manual and on the product.
- Clean only with a dry cloth. Unplug from AC supply before cleaning.
- Do not use this product near water and avoid any exposure to water.
- Before connecting this product to any AC supply, make sure to check whether the AC mains voltage and frequency match the indication on the product and its packaging.
- Only connect this product to an AC supply with sufficient power handling, protective earth connection, ground-fault (earth-fault) protection and overload protection.
- Disconnect the product from the AC supply during thunderstorms or longer periods of being unused.
- Make sure any heat sink or other cooling surface, or any air convection slot, is exposed sufficiently to free air circulation and is not blocked.
- Do not operate this product in environmental temperatures exceeding 35 degrees Celsius and/or 85% relative humidity.
- Position the product in a safe and stable place for operation, out of reach of unauthorized persons.
- Make sure any cable connections to and from the product are neither subject to potentially destructive mechanical impact nor present any risk of stumbling or other accident risk to people.
- Audio equipment may generate sound pressure levels sufficient to cause permanent hearing damage to persons. Always start up at low volume settings and avoid prolonged exposure to sound pressure levels exceeding 90 dB.
- Do not open this product for service purposes. There are no user-serviceable parts inside. Warranty will be void in any case of unauthorized service by the user or other not authorized persons.
- Take any precaution required by local law, applicable regulations or good business practice to avoid injury of people or material damage by use of this product.

Explanation of symbols used in this manual and on the product:



**ATTENTION!**  
Read manual before installation and operation.



**DANGER!**  
Safety hazard.  
Risk of injury or death.



**WARNING!**  
Hazardous voltage.  
Risk of severe or fatal electric shock.



**WARNING!**  
Fire hazard.

## Description

The ZPR2820 4+2 Channel 2-Zone Mixer is a stereo mixing console with 2 microphone inputs, 8 stereo inputs, adjustable talk-over and two balanced master stereo outputs, with one of them being configurable as a zone output. The numerous installation-specific features make this unit a very versatile choice in any environment from leisure to commercial applications, where foreground and background music replay need to be combined, and where live user interaction is required.

## Health advice

This unit produces and absorbs electromagnetic radiation. The strength of radiation and the sensitivity for disturbing interference matches the CE and FCC requirements. A corresponding sign is printed on the backside of the unit. Any change or modification may affect the behavior of the unit concerning electromagnetic radiation, with the CE requirements eventually not to be met any more. The manufacturer takes no responsibility in this case.

## Functional advice

This unit is immune to the presence of electromagnetic disturbances – both conducted and radiated - up to a certain level. Under peak conditions, the unit is classified to show a “class C” performance criteria and may encounter temporary degradation or loss of function which may need manual help to recover. In such case, disconnect the AC power from the unit and reconnect it again to recover.

## Environmental advice

This unit is built to conform to the ROHS standards and the WEEE directive 2002/96/EC of the European Parliament and of the Council of the European Union. Under these regulations, the product shall not be discarded into regular garbage at the end of its life, but shall be returned to authorized recycling stations.

## Unpacking

Please check that the box contains the following items:

- Main parts: 1 pc. ZPR2820 main unit
- 1 pc. Mains cable
- 1 pc. Operation manual

If any part is missing, please contact your dealer immediately for replacement.

## Warning



After unpacking, and before plugging the AC cord in the wall outlet, check whether the AC mains voltage and frequency is the same as this product is specified for (see rear panel of product). Whenever the specified voltage or your AC plug should not match the local conditions, do NOT plug the AC cord into the wall outlet and contact your dealer immediately.

## AC mains voltage setting

If the AC mains voltage of your power outlet and the setting of the AC supply voltage on your unit do not match, contact your dealer, contractor or a qualified service workshop to change the setting of the AC voltage selector. The AC voltage selector switch is located on the side panel of the unit, close to the AC inlet.

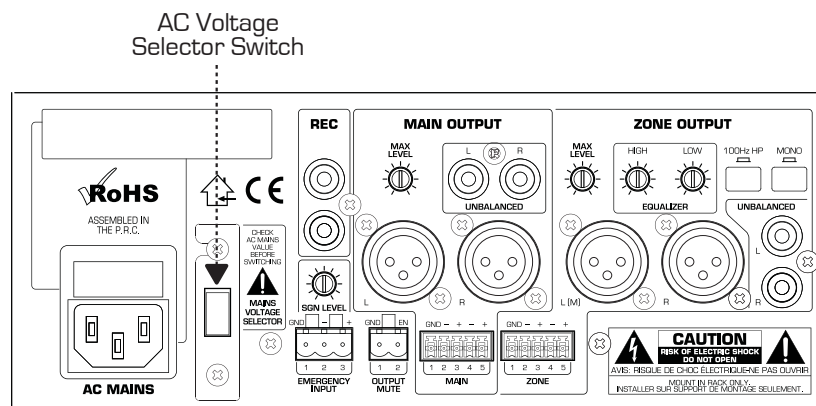

## Controls and Connections

### Connections - Rear

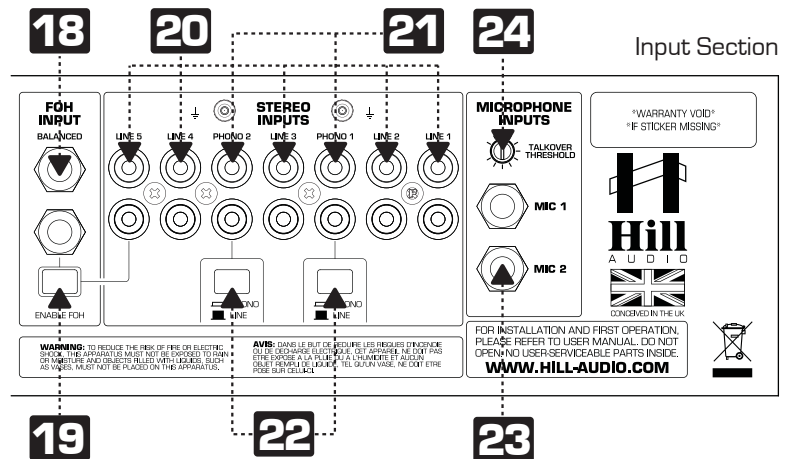

### Output Section

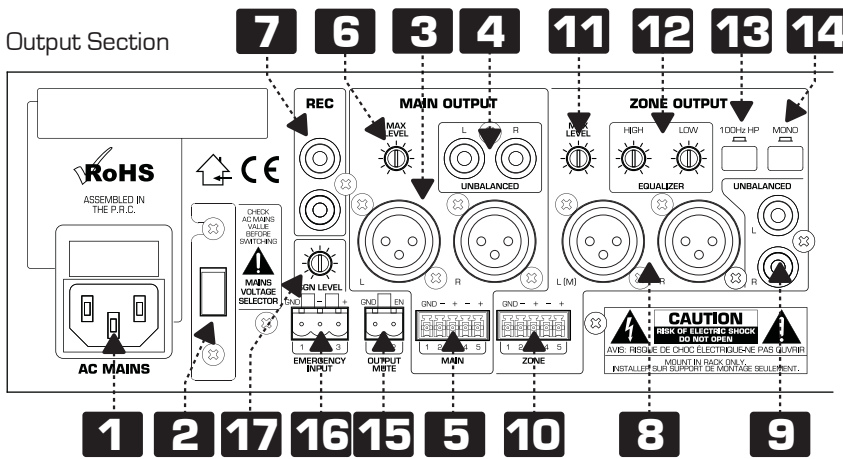

### Controls - Front

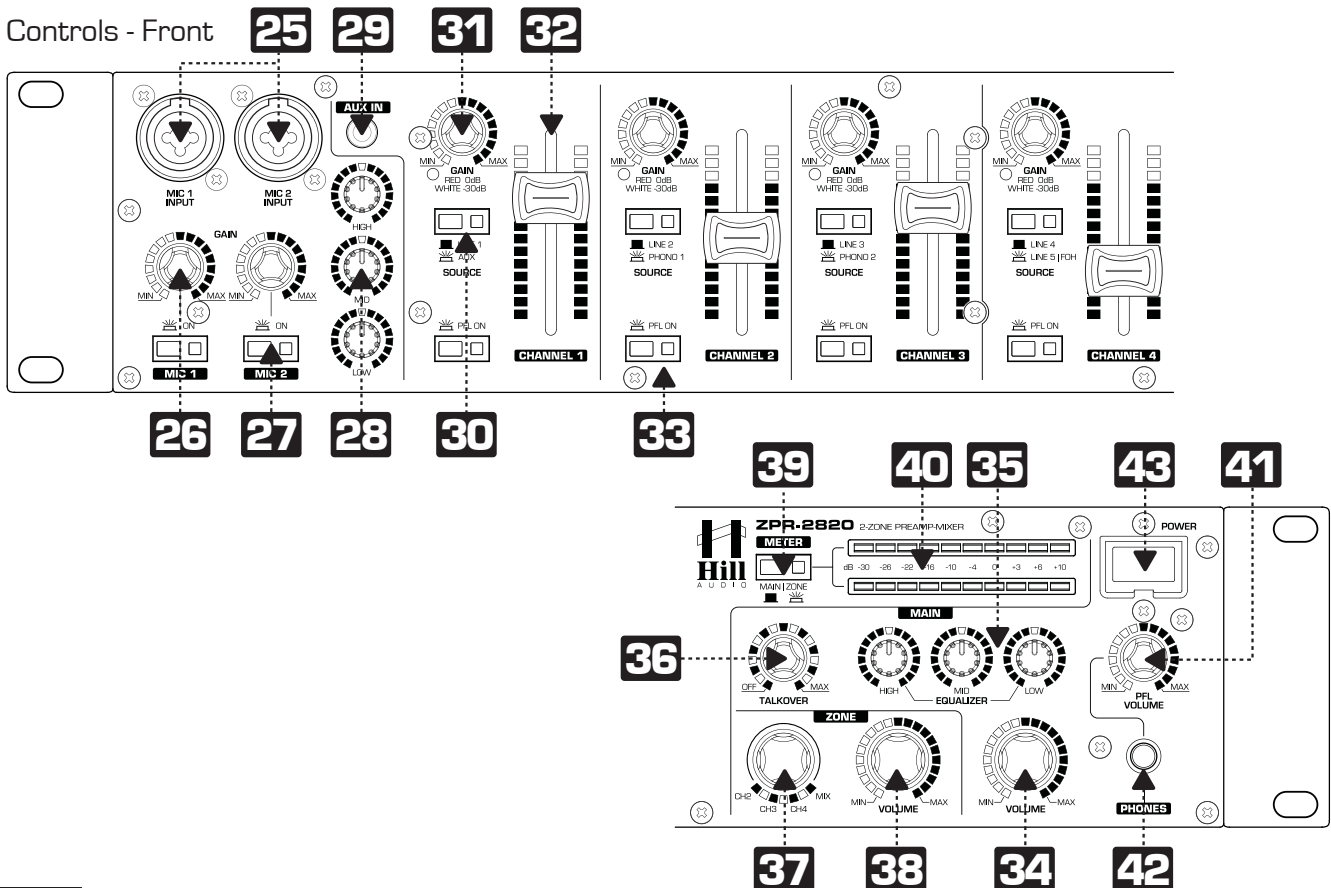

## Functional Description

The ZPR2820 is a zoning mixer which allows to connect up to two microphones and 8 stereo sources to a total of 6 inputs. The two microphones have a dedicated equalizer and an automatic talkover function which provides microphone priority over program material; the stereo inputs have faders and thus allow live mixing of the input signals. One of the stereo inputs is balanced, specifically catering for connections to the output of a stage mixer, thus making the ZPR2820 a perfect centre piece of a small hospitality venue sound system with occasional live music. The main output is a stereo output carrying the mix of the input channels; an additional stereo zone output can either carry the same signal as the main output or any of the input signals directly. A prelistening section completes the user interface, while remote muting and emergency signal replay facilitate the use in installed sound systems.

- 1** AC inlet and fuse holder. Use the supplied AC cord to connect the unit to AC mains. Make sure voltage and frequency stated and set on the unit comply with your local AC supply. The fuse can be accessed by the small drawer at the AC inlet. To change the fuse, unplug the AC cord first, pull out the fuse drawer and replace the fuse **ONLY** with a fuse of **SAME** voltage and rating. If the fuse blows again after replacement, hand over the unit to qualified service personnel.
- 2** AC Voltage Selector Switch. Switches the AC supply voltage between 110/115V and 220/230V AC. See previous chapter for details.
- 3** Stereo Main output. This is a balanced stereo XLR output carrying the main output signal controlled by [34].
- 4** Stereo Main output. This is an unbalanced RCA output carrying the same signal as output [3].
- 5** Stereo Main output. This is a balanced terminal block output carrying the same signal as output [3].
- 6** Maximum level setting for Stereo Main output. This control allows to limit the maximum level at the outputs [3]/[4]/[5] in order to match the connected sound system. Adjustments made on this control will not be displayed by the output level meter [40]. Adjustments shall be made with a small screw driver. Note that the total angle is 300 degrees; do not apply excessive force with the screw driver.
- 7** Record output. This is an unbalanced stereo output carrying the same signal as the main outputs [3]/[4]/[5], but not influenced by the main volume control [34]. This is normally used for recording the output to an external tape, CD or memory device.
- 8** Stereo Zone output. This is a balanced stereo XLR output carrying the main output signal controlled by [38].
- 9** Stereo Zone output. This is an unbalanced RCA output carrying the same signal as output [8].
- 10** Stereo Zone output. This is a balanced terminal block output carrying the same signal as output [8].
- 11** Maximum level setting for Stereo Zone output. This control allows to limit the maximum level at the outputs [8]/[9]/[10] in order to match the connected sound system. Adjustments made on this control will not be displayed by the output level meter [40]. Adjustments shall be made with a small screw driver. Note that the total angle is 300 degrees; do not apply excessive force with the screw driver.
- 12** Equalizer for Zone output. This is a 2-band stereo equalizer to adjust the frequency response of the output. Adjustments shall be made with a small screw driver. Note that the total angle is 300 degrees; do not apply excessive force with the screw driver.

- 13** 100Hz Highpass (HP) filter for Zone output. In pressed position, this switch removes frequencies below 100Hz from the Zone output, helping to adapt to zone speaker systems with limited low-frequency response (like ceiling speakers).
- 14** Mono Switch for Zone output. In pressed position, the left and right outputs of the Zone signal are summed to deliver a mono signal. Useful for installations where the zone speaker system does not allow stereo reproduction.
- 15** Music Mute input. This is a terminal block input which allows to remotely mute all output signals (Stereo Master, Zone) by simply shortening the contacts.
- 16** Emergency input. This is an auto-sensing, balanced terminal block input which allows the connection to an emergency evacuation system. Once a signal is present on this input, all output signals (Main, Zone) will be muted and the emergency message/signal from this input will become audible instead. Please note that the internal microphones (23)/(25) are included in this muting process and can not be used while an emergency message is broadcasted.
- 17** Emergency volume control. This control allows to set the level with which the signal fed into the emergency input (16) will be replayed at the two master outputs (3)/(4)/(5) and (8)/(9)/(10).
- 18** FOH input. This is a 1/4" TRS balanced stereo input specifically designed to allow the connection of the output of a stage mixer, in order to use the connected sound system for the replay of the stage mixer's signal. This is useful in applications where apart from stereo source replay also live music is performed over the same sound system. The FOH input can be routed to input channel 4 instead of the Line5 signal by pressing the FOH enable switch (19).
- 19** FOH Enable switch. In pressed position, this switch routes the FOH signal (18) to Channel 4 instead of the Line5 RCA input.
- 20** Line inputs. These RCA connectors provide inputs for line-level signals to the assigned channels.
- 21** Phono inputs. These RCA connectors provide inputs for phono-level signals with RIAA equalization to the assigned channels. The sensitivity can be switched to line level by means of the switches (22).
- 22** Sensitivity switch for Phono inputs. Sets the sensitivity of the Phono inputs (21) to Phono with RIAA equalization (pressed) or Line level (released).
- 23** Microphone input for MIC1 and MIC2. These are balanced 1/4" TRS connectors, which can be internally set to either carry phantom power or not, thus these inputs can be used both with condenser and dynamic microphones. Please see section "microphone phantom power setting". The signal of these inputs is connected in parallel with the front-panel inputs (25).
- 24** Talkover Threshold Control. Sets the level of the microphone signal at which the music signal is automatically attenuated. Note that the amount of attenuation is determined by the damping control (36)
- 25** Microphone input for MIC1 and MIC2. These are balanced Combo XLR+1/4" TRS connectors, which can be internally set to either carry phantom power or not, thus these inputs can be used both with condenser and dynamic microphones. Please see section "microphone phantom power setting".

- 26** Level control for microphone inputs. Allow the individual adjustments of the levels for MIC1 and MIC2.
- 27** Microphone ON/OFF switches for MIC1 and MIC2.
- 28** Microphone Equalizer. Allows the adjustment of the tonal balance for both microphone simultaneously inputs in three voice-specific frequency bands with an adjustment range of  $\pm 12$ dB.
- 29** AUX Input for CHANNEL1. This is a 3.5mm Mini-TRS stereo socket which allows to connect sources like MP3 players etc. Once a plug is inserted, the rear panel inputs for CHANNEL1 are disabled and the connected source is active.
- 30** Input Selector switch for input channels. Selects one of two rear-panel sources to be used with the respective input channel.
- 31** Input Gain control with Level LED for Input channels. Allows to compensate for different source levels. A white Signal LED indicates a signal present, a red Peak LED helps to adjust sources to the same level while keeping required headroom. The Peak LED shall only occasionally be lit.
- 32** Level control of input channels. Allows adjustment of the respective channel level.
- 33** PFL switch for input channels. Assigns the respective channel to the headphone bus for pre-fader-listening (PFL) by means of the headphone output [42]. A LED indicates the pressed position.
- 34** Main [stereo] output level control. Determines the main output level present at outputs [3]/[4]/[5].
- 35** Equalizer for Main [Stereo] output. This is a 3-band stereo equalizer to adjust the frequency response of the output.
- 36** Talkover Damping Control. This control determines the amount of damping applied to the program signal when a microphone is spoken into. Fully turned clockwise, maximum attenuation is applied, being turned fully counter-clockwise, the talkover function is off. The threshold level from which on this function is enabled can be set by the rear panel control [24].
- 37** Zone source selection switch. This rotary switch allows to either use the master mix bus [same signal as carried by the stereo master output [3]/[4]/[5]] or any of the individual, assigned source signals to the Inputs 2/3/4, to be used as a source for the Zone output.
- 38** Zone output level control. Determines the zone output level present at outputs [8]/[9]/[10].
- 39** Level Meter Source switch. Switches the meter [40] between the Main and the Zone signal.
- 40** Main [Stereo] output level meter. Displays the output level of the stereo main output or the zone output, depending on the setting of switch [39]. Note that the level limitation applied by means of the rear-side maximum level controls [6]/[11] is not displayed on the meter.
- 41** PFL level. Determines the signal volume at the headphone output [42]. Always set this control to minimum before putting on headphones, as sudden loud impact may damage your ears.
- 42** Headphones output. A 1/4" TRS connector to connect a headphone. Turn the PFL level [41] down before plugging in any headphones.
- 43** Power switch. Switches the unit on and off. Make sure to switch the unit off when not in use.

## Internal Settings



### WARNING - DANGER

Changing the internal settings requires to open the unit. Prior to opening the unit, the unit shall be disconnected from any AC supply. Any work on an open unit shall be expedited only by qualified, certified personnel.

### Microphone phantom power setting

While most applications will work well with dynamic microphones, on certain occasions the use of a condenser microphone may be required. To supply the necessary voltage to the microphone, the ZPR2620 provides an internal option to activate phantom power for the Microphones MIC1 and MIC2. Open the unit and locate the rear PCB as shown below. Set the jumper as required.

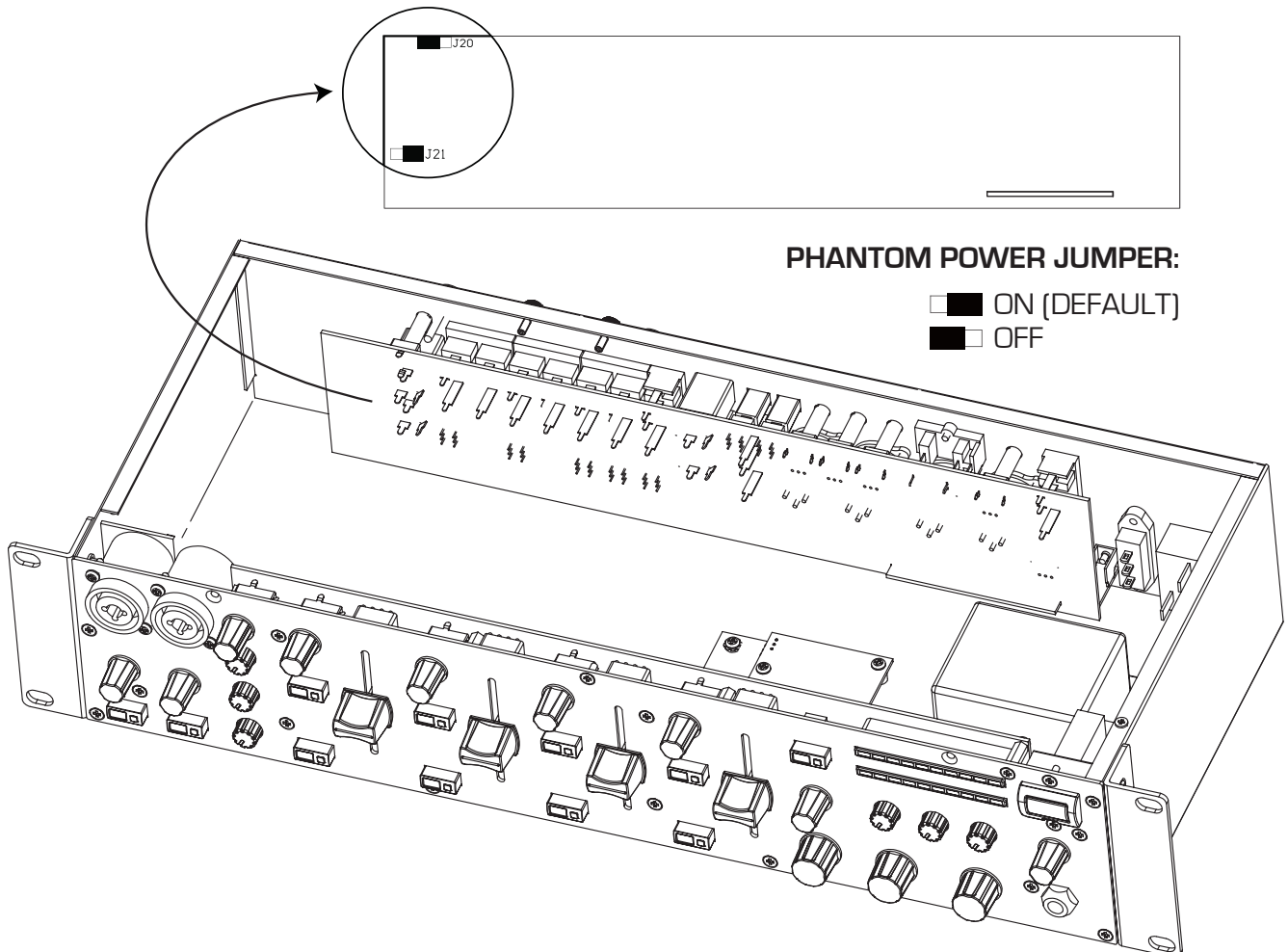



## Operation

### A. Connections

For connecting this unit to AC mains, please note:

- Check whether the AC mains voltage and frequency is the same as this product is specified for (see rear panel of product). Whenever the specified voltage or your AC plug should not match the local conditions, do NOT plug the AC cord into the wall outlet and contact you dealer immediately.
- Do not operate this unit without the line cord earth ground connected. To do so may increase the risk of electric shock and increase line cord conducted emissions.

For making audio signal connections, always remember that good and reliable connections are a basic requirement for good sound and reliable operation. Bad soldering of cables can result in intermittent audio signals or temporarily lost ground connections, hence always use good cables. In case of doubt about making proper connections, please see check the standard pin assignments required for proper operation in the following section of this manual.

### B. Powering up

Following a proper power-up sequence protects your equipment – specifically speakers – and your ears. Follow the below procedure:

- Turn down all output volume controls of any equipment in your audio system.
- Switch on your audio sources first (Tuners, CD Players, PC's with soundcards, Tapedecks, etc.)
- Switch on the audio mixer
- Switch on any audio processor between the mixer and the amplifier(s) [if any].
- Switch on the amplifier(s).
- Turn up the audio level on your sources if such controls are provided.
- Set the audio output of your mixer to a low level.
- Set the audio output of any audio processor between the mixer and the amplifier(s) to a medium level [if any such processors].
- Turn up the volume controls of your amplifier(s) slowly.
- Make adjustments to all volume settings as needed.

For switching off, follow the inverse sequence – always switch off your amplifier(s) first, then any processors between mixer and amplifier(s), then the mixer, then the sources.

### C. Use

Apart from using good equipment, good sound comes from using it correctly. Level setting mistakes are one of the common reasons why even good equipment may not perform as desired. For setting levels, please be reminded that two guidelines need to be followed:

- Avoid distortion by leaving some headroom. Never overrun any audio-equipment's inputs. Level meters and displays allow you to make sure that signals do not enter critical levels.
- Avoid unnecessary amplification by using as little attenuation as possible. For example, if you turn down the input gain of a mixer to minimum, and then increase the main output of the mixer to maximum to drive your amplifier properly, you will create unnecessary noise, as you first dispose of some already existing signal level, and then later apply amplification [tainted with noise] to make it up.

Obviously, these two requirements are marking a levelling window that the operator must match to achieve a good sound with as little distortion and noise as possible.



#### **WARNING - HEALTH RISK**

Excessive volume levels on headphones or other sound systems may cause hearing damage. Always turn the volume control to minimum when you switch the unit on, and avoid prolonged exposure to sound pressure levels exceeding 90dB.

## Connections

The ZPR series mixers use the below connector types, for which the pin assignment must comply with the following specification. Always make sure to use good connectors and cables to ensure proper operation. Balanced connections are to be preferred over unbalanced connections where applicable and feasible. Avoid unbalanced connections exceeding 2m of cable length.

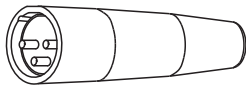
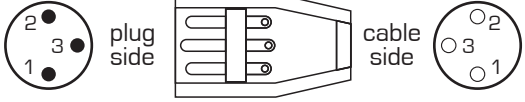
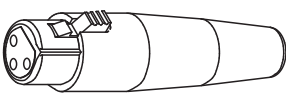
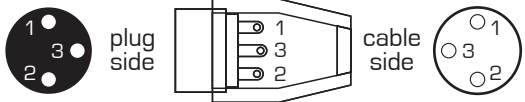
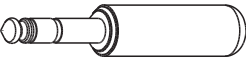
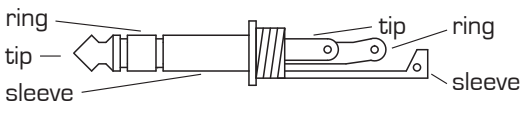
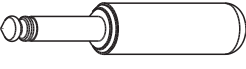
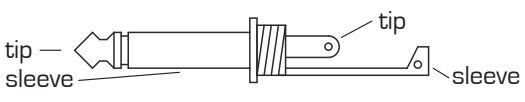
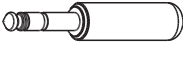
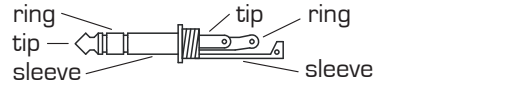
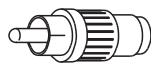
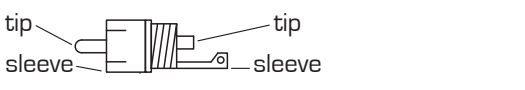
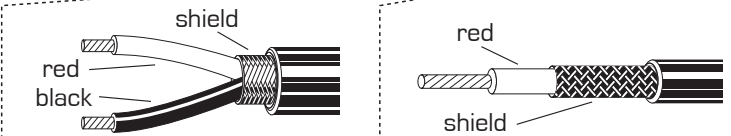
	Structure	Balanced connection	Unbalanced connection
<b>XLR male</b> 		red = 2 black = 3 shield = 1	red = 2 shield = 1+3
<b>XLR female</b> 		red = 2 black = 3 shield = 1	red = 2 shield = 1+3
<b>6.35mm TRS-stereo</b> 		red = tip black = ring shield = sleeve	red = tip shield = sleeve+ring
<b>6.35mm TRS-mono</b> 		red = tip black = sleeve shield = uncon.	red = tip shield = sleeve
<b>3.5mm TRS-stereo</b> 		red = tip black = ring shield = sleeve	red = tip shield = sleeve+ring
<b>RCA</b> 		red = tip black = sleeve shield = uncon.	red = tip shield = sleeve
<b>CABLE Types</b>			
	2-conductor shielded cable (for balanced connections)		
	1-conductor shielded cable (for unbalanced connections)		

## Technical Specifications

Signal/Noise.....	>82dB (Line)	AC IN (US version).....	AC110-120V~ 60Hz
Crosstalk Damping.....	>65dB (Line)	Power consumption.....	max. 18W
THD.....	<0.05% (Line)	Dimensions.....	W483(427)xH88.0xD183.5mm (parentheses = without rack ears)
Frequency response.....	20Hz – 20 kHz	Weight.....	2.8kg
AC IN (EU version).....	AC220-250V~ 50Hz		

## Block Diagram

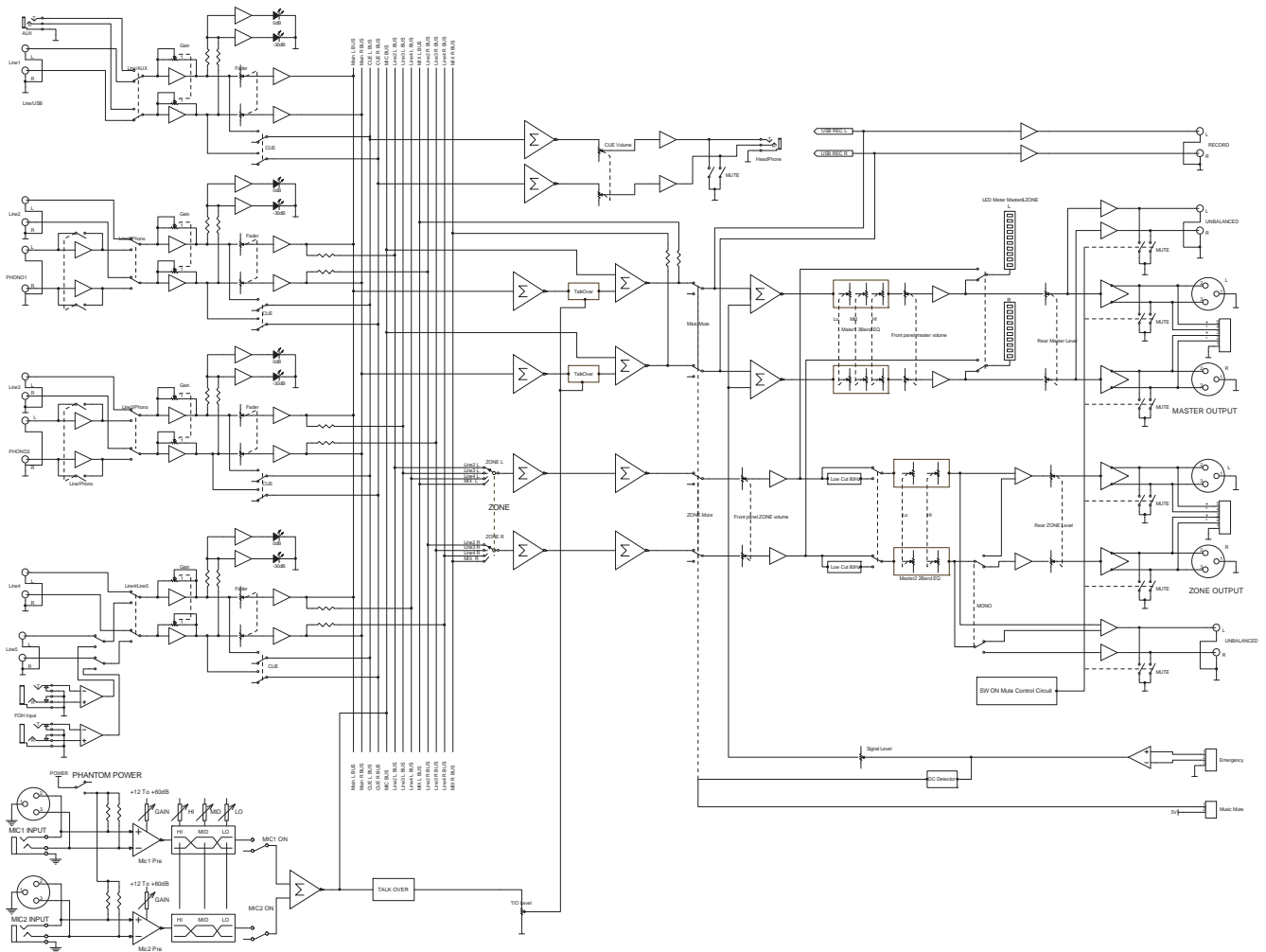

## Maintenance and warranty

While we have chosen the best components to make this product as rugged and reliable as possible, some parts in audio products (potentiometers, faders, switches) are subject to wear which is a matter of operation cycles, and not of time. While providing a full time-based warranty according to the country's of purchase requirements on the function of the electronic circuitry, we hence have to limit the warranty on such electro-mechanical parts to 90 days from the date of purchase.

In many cases, malfunction of electro-mechanical parts occurs due to dust contamination, which may require cleaning of such parts. As the inside of such parts is not accessible, a common practice is to use cleaning fluids in the shape of sprays. Please be reminded that many of such fluids contain chemicals which may wash away the dust but at the same time corrode or damage contact surface and may cause cosmetic damage to other parts. We hence explicitly exclude any claims for exchange of damaged part due to mechanical or chemical impact.

# EC Declaration of Conformity

Manufacturer: Adelto Technologies Limited  
Address: Vanguard Way, Shoeburyness, Essex SS3 9QY, UK

We declare on our own responsibility, that the equipment

**Hill Audio ZPR2620**  
**Hill Audio ZPR2820**  
**Hill Audio ZPR4620**

is in conformity with the following directives and standards or regulations:

**EMC Directive 2004/108/EC**  
EN55103-1:2009 (Emissions)  
EN55103-2:2009 (Immunity)  
EN61000-3-2:2006 + A1:2009 + A2:2009  
EN61000-3-3:2008

**LVD Directive 2006/95/EC**  
EN60065:2002 A1:2006 + A11:2008 + A2:2010

**ROHS Directive 2002/95/EC**

and is marked as follows:



Shoeburyness, 10. May 2013  
Place and date of issuing

  
Authorized Signature

[www.hill-audio.com](http://www.hill-audio.com)



Hill Audio products are developed, manufactured and distributed by  
**Adelto Technologies**  
Vanguard Way, Shoeburyness, Essex SS3 9QY, UK  
[www.adelto.com](http://www.adelto.com) | [sales@adelto.com](mailto:sales@adelto.com)