

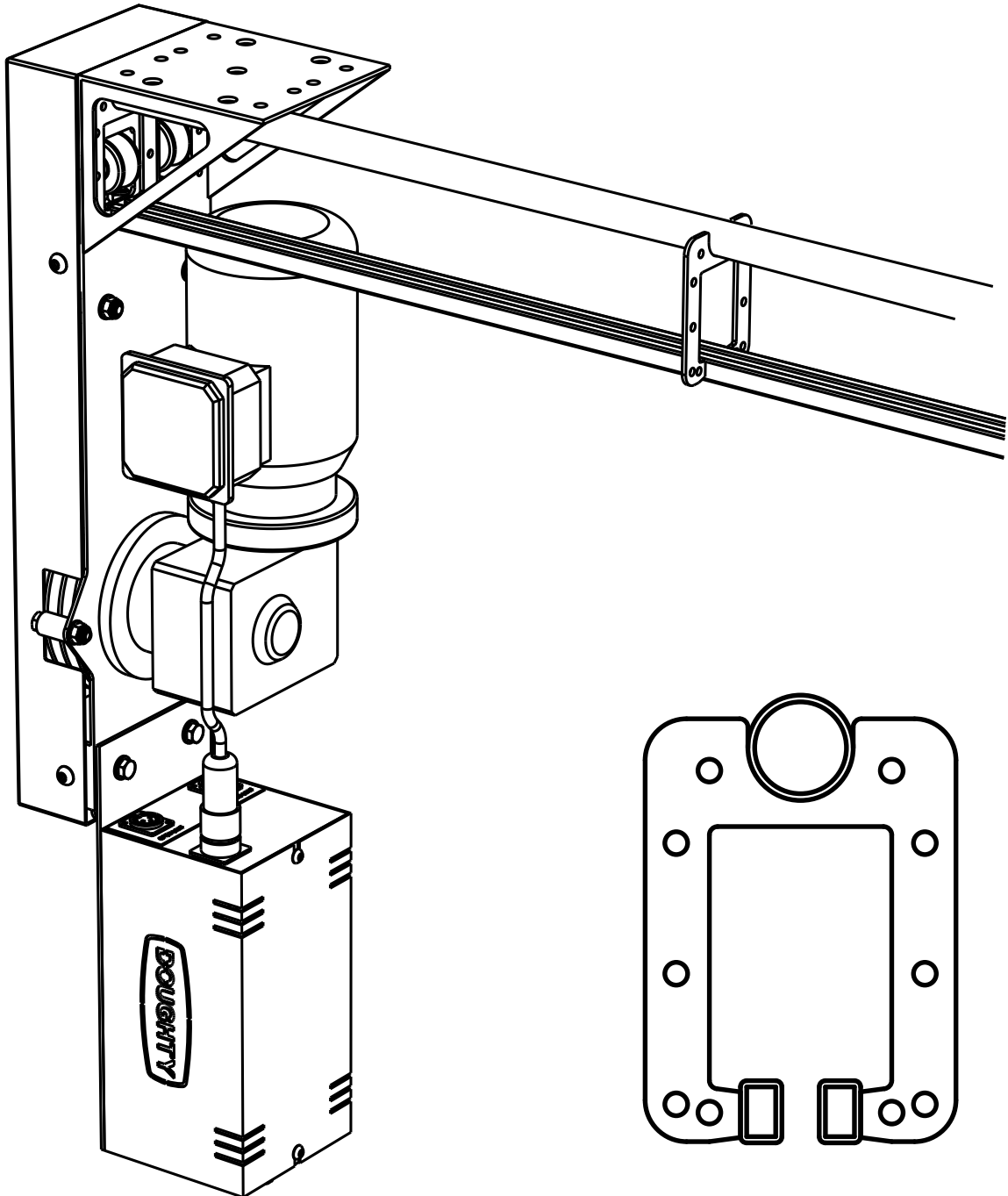

# User Manual

[www.doughty-engineering.co.uk](http://www.doughty-engineering.co.uk)

## Six Track



Original Instructions

Revision 3 04/16/18

[www.doughty-engineering.co.uk](http://www.doughty-engineering.co.uk)

## Introduction

Six Track is a curtain track system made up from a variety of interchangeable parts to provide a flexible efficient system.

Six Track can be configured as:

### 1. A Walk-along System.

This is a system where a person opens/closes the curtains/drapes manually by pulling the actual curtain cloth. This system can be straight or curved being a single swipe or a system with an overlap.

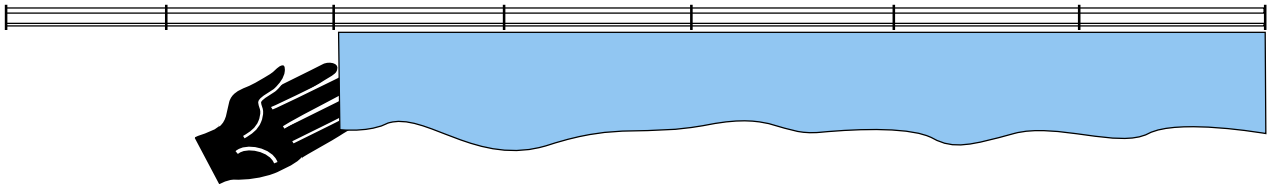

### 2. A Manual Line Operated System.

This system is operated with an 8mm polyester hauling line. The hauling line can be operated by hand, or with a wall or floor mounted Manual Track Drive. This system can be straight or curved being a single swipe or a system with an overlap.

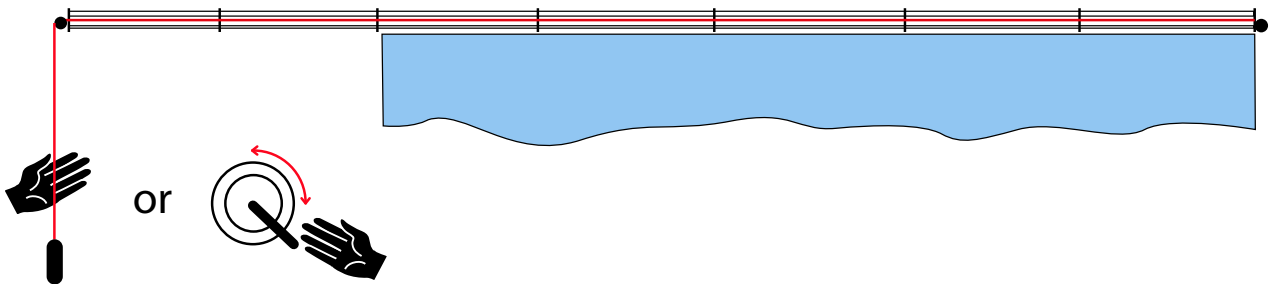

### 3. A Motorised System.

This system is operated with an 8mm hauling line. The hauling line is operated by an Electric Track Drive in conjunction with limit switches to set the travel. This system can be straight or curved being a single swipe or a system with an overlap.

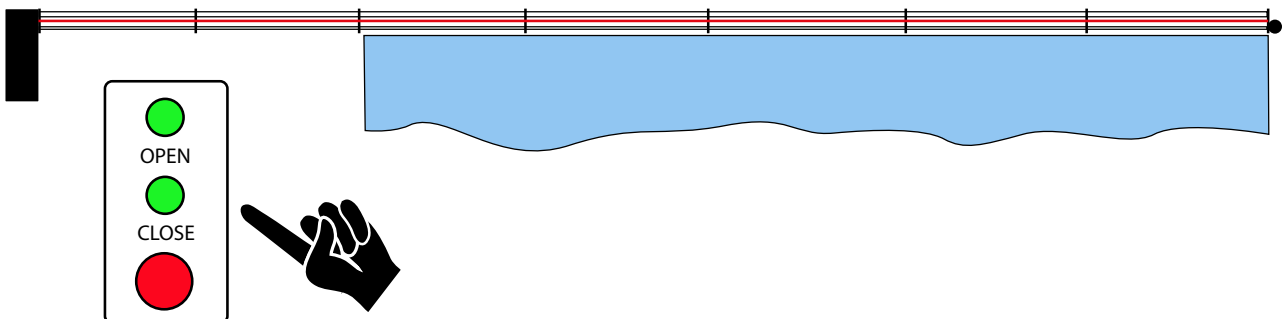

Track Drives can be Track or Wall mounted with a remote pendant.

## General Installation

Six Track will be installed at a height such that any failure would be hazardous.

Installation must be undertaken under the supervision of a competent person.

All suspension points must be assessed to ensure they are adequate to suspend the load.

Before starting the installation the load for each support should be calculated allowing for the weight of all the track and accessories as well as the curtain whether open or bunched or part bunched as during opening. Care must be taken to allow for loads imposed during operation, the load on a twin head pulley may be increased by up to 50KG due to the effect of the hauling line.

The maximum recommended length of a single span track is 10.0 metres and 18.0 metres for an overlap track system.

The maximum distance between track supports is approx 2.25m for open cloth and approx 1.60m for bunched cloth.

The max load per runner is 6.0Kg and has a recommended spacing of 300mm when the cloth is open. Swivel hooks are best used on the curtains instead of eyelets or ties.

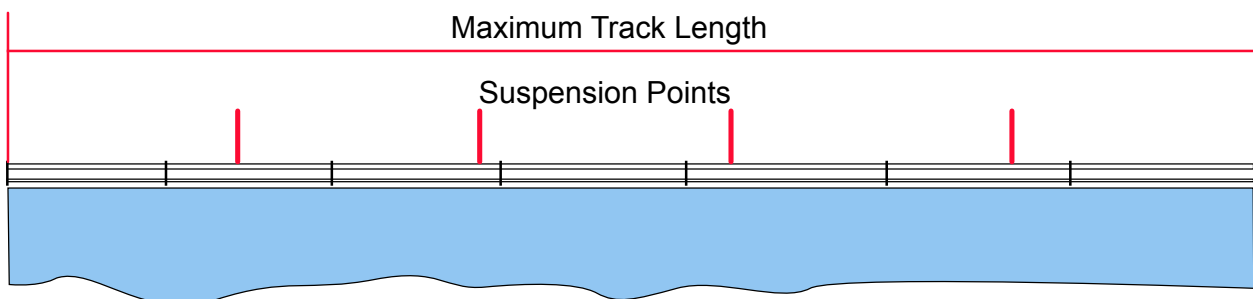

A Typical Swivel Hook

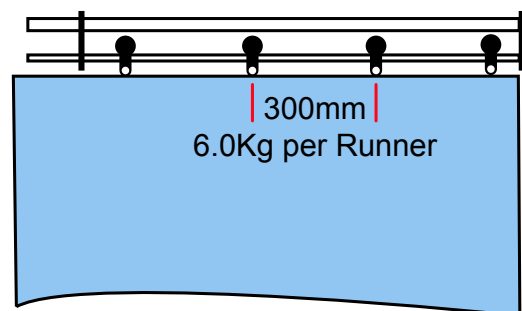

## Six Track Straight Sections.

The following straight sections are available:

T63705	0.25m Straight
T63706	0.50m Straight
T63707	0.75m Straight
T63708	1.00m Straight
T63710	2.00m Straight
T63715	3.00m Straight

Custom lengths can be made to order or the track can be cut to length on site and used with a Bolt On End Plate or a Adaptor Plate. Each Six Track Straight section is supplied with a joint plate to aid alignment.

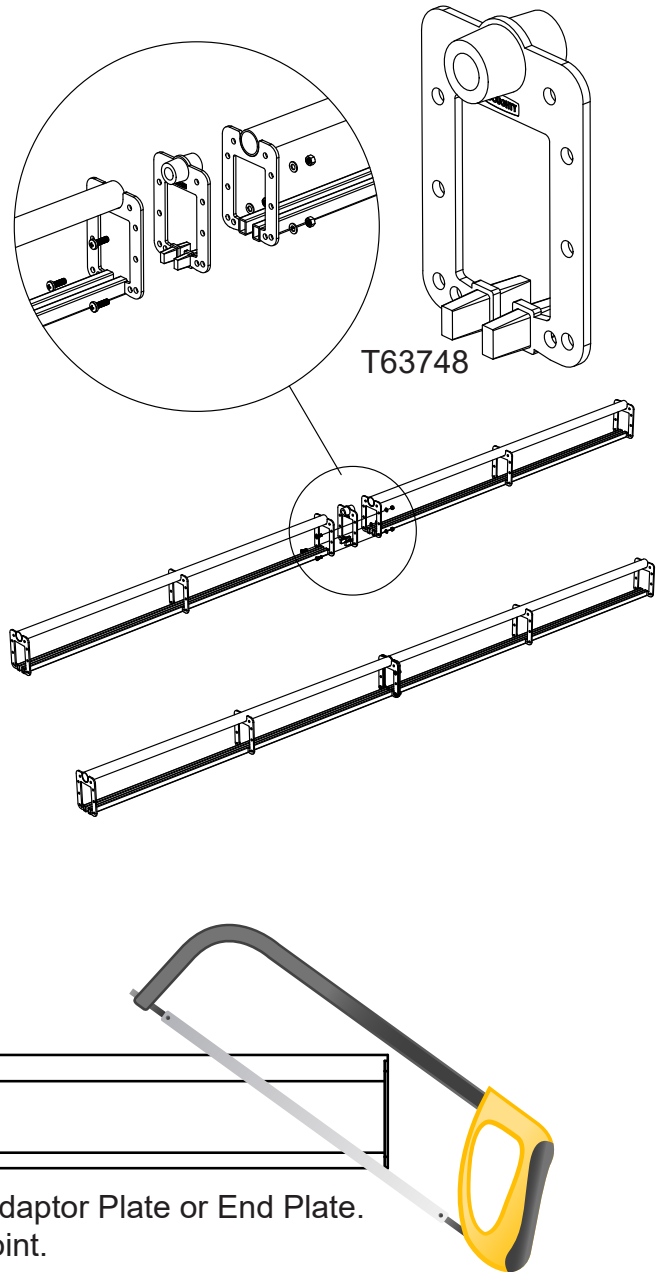

T63795: Fixing Kit

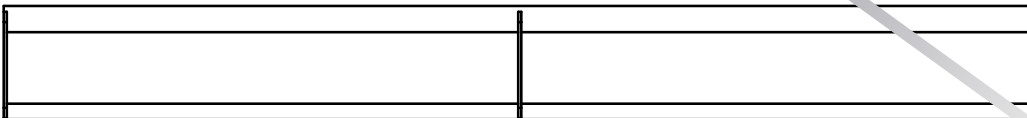

Six Track can be cut on site & fitted with an Adaptor Plate or End Plate. A minimum of four fixings are required per joint.

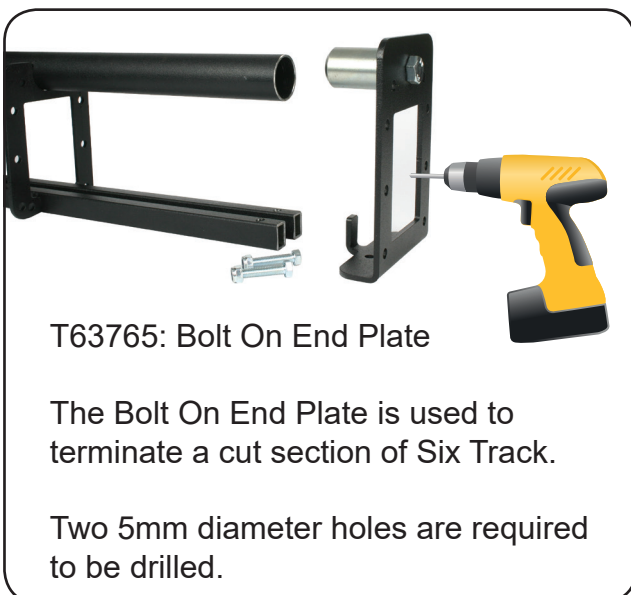

T63765: Bolt On End Plate

The Bolt On End Plate is used to terminate a cut section of Six Track.

Two 5mm diameter holes are required to be drilled.

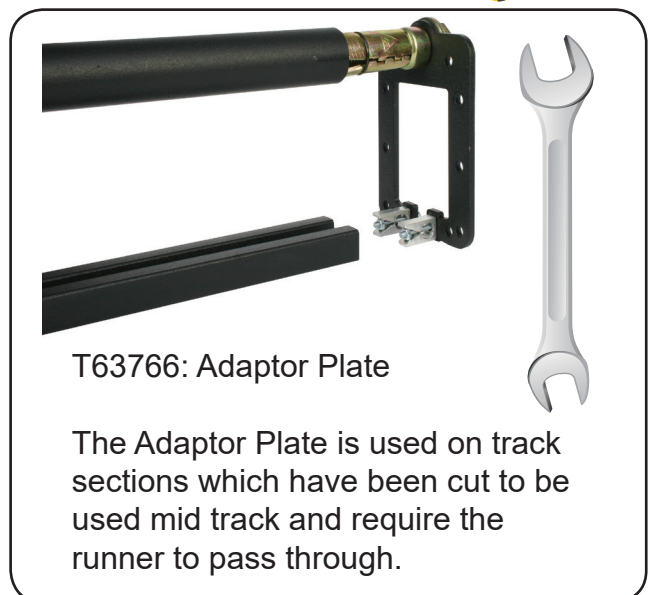

T63766: Adaptor Plate

The Adaptor Plate is used on track sections which have been cut to be used mid track and require the runner to pass through.

## Six Track Curved Sections.

The following curve sections are available:

T63730	0.50m x 90°
T63733	0.60m x 90°
T63731	0.75m x 90°
T63734	0.90m x 90°
T63732	1.00m x 90°
T63738	2.00m x 90° (2 parts)
T63739	3.00m x 90° (3 parts)

T63735	0.50m x 45°
T63736	0.75m x 45°
T63737	1.00m x 45°

Custom curves can be made to order.

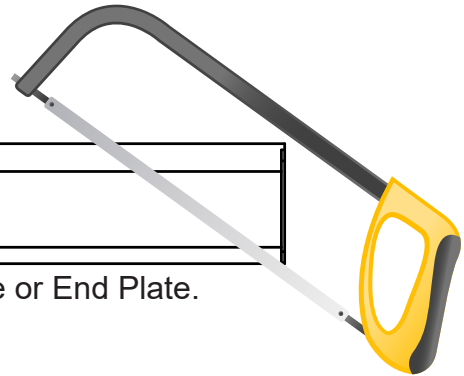
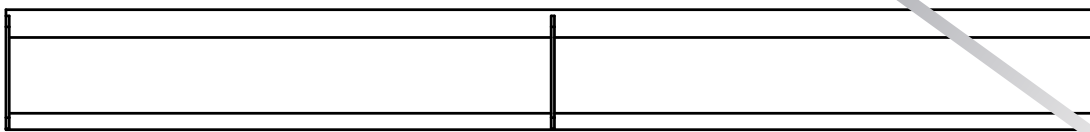
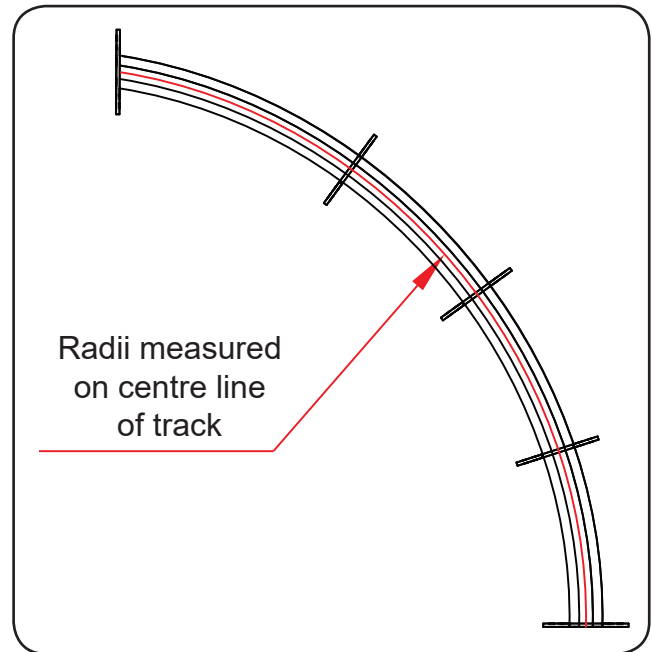

Six Track can be cut on site & fitted with an Adaptor Plate or End Plate.  
A minimum of four fixings are required per joint.

Six Track Runners have a SWL of 6Kg and are recommended to be used at 300mm intervals.

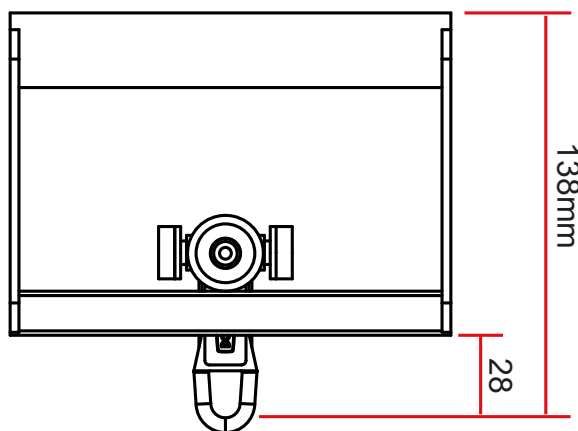

T63756: Ball Raced Runner  
T63757: Plain Runner

A Master Runner is used to lead the curtain on every system, Walk-along, Line operated and Electric track drive.

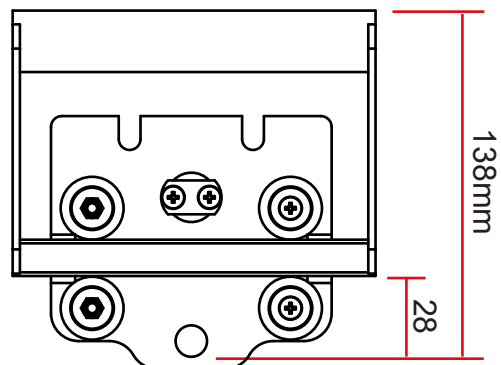

T63755: Master Runner

Six Track is suspended by attaching clamps/brackets to the Ø25mm top tube of the rail sections.

There are a variety of brackets available to cover most install situations.

Care must be take to ensure all suspension points are adequate to suspend the load.

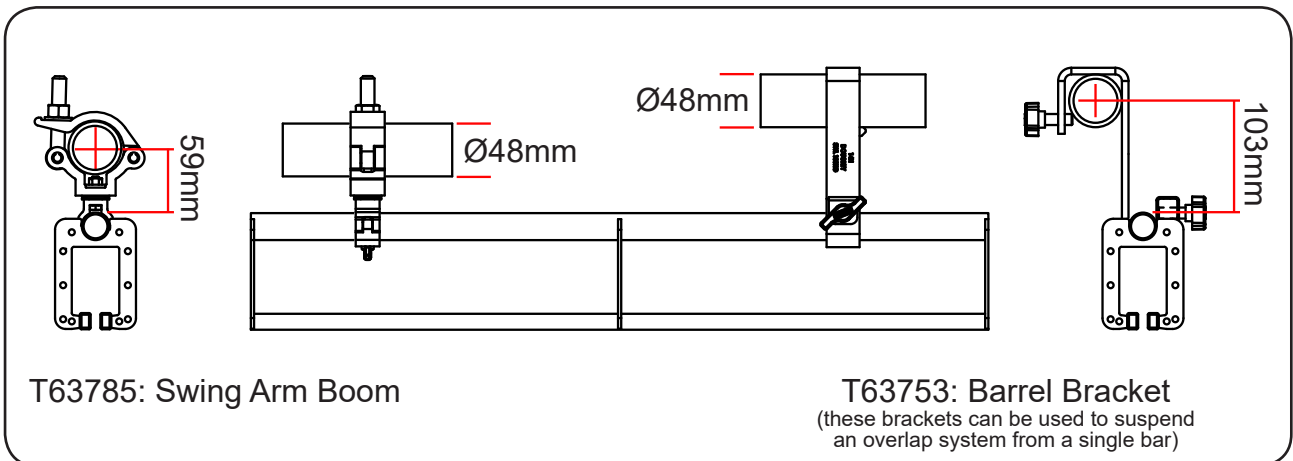
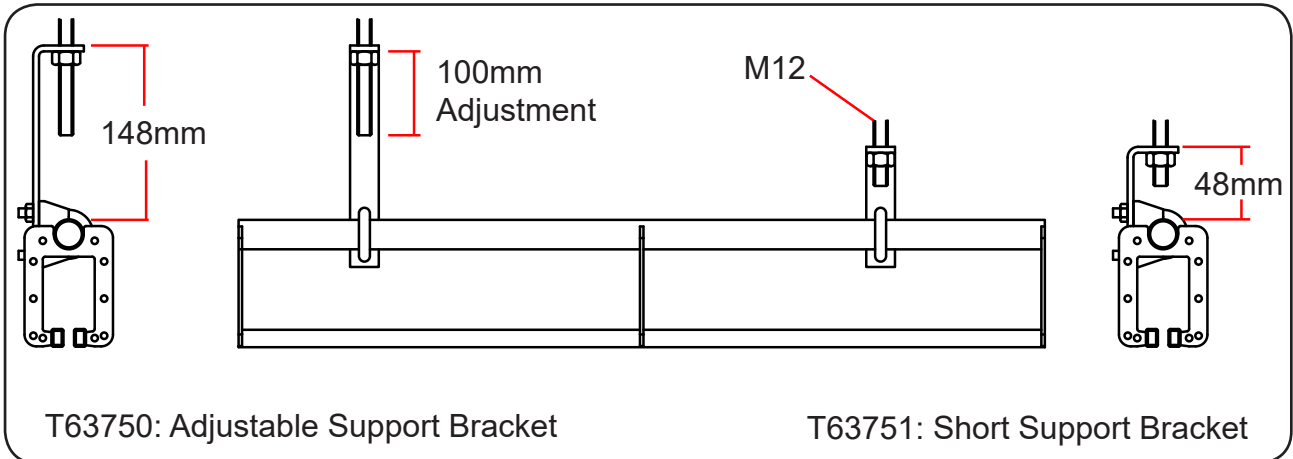

Twin Tracks and Overlaps are spaced apart with purpose made brackets.

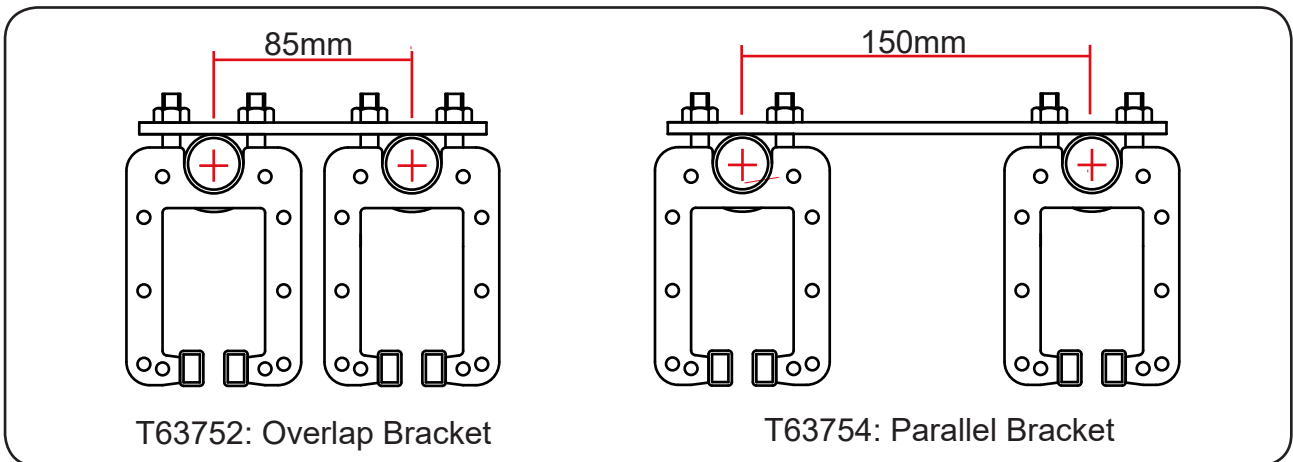

# Walk-Along Systems - Single Swipe

Six Track walk-along systems are basic curtain tracks which are operated by moving the curtains by hand.

Listed below are the components required to make a system.

## Check List:

1. Track Sections
2. Suspension Brackets
3. Fixing Kit (for joining track sections)
4. Curtain Runners
5. End Stops
6. Fixing Kit (for joining track sections)

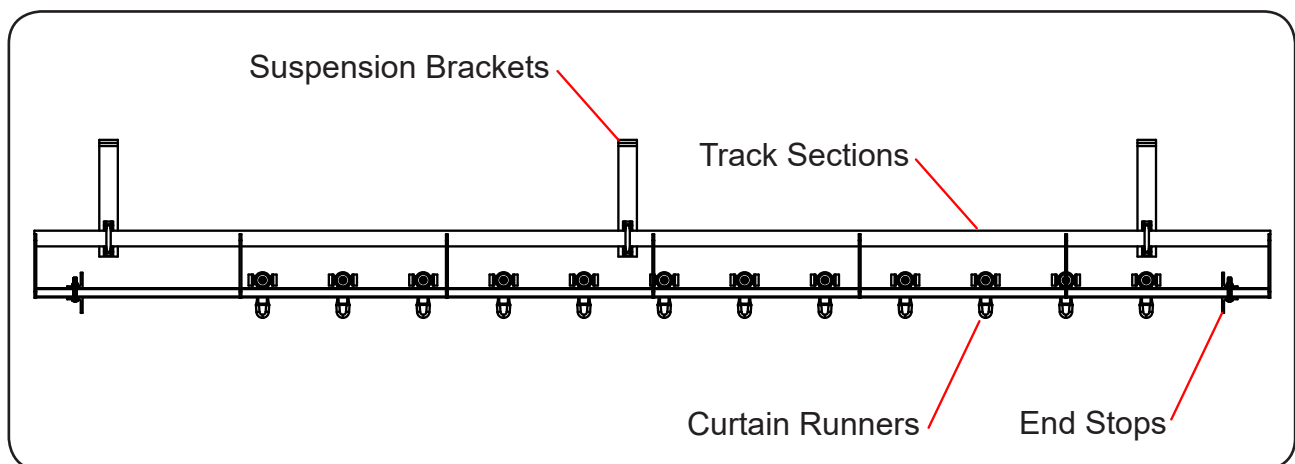

## Walk-Along Track Kits

The following track kit include all the components to make a straight walk-along system. Each kit includes the recommended quantity of T63750 Adjustable Support Brackets. Contact [sales@doughty-engineering.co.uk](mailto:sales@doughty-engineering.co.uk) for a full component list.

T63941:	4.0m	Straight Kit	T63947:	10.0m	Straight Kit
T63942:	5.0m	Straight Kit	T63948:	11.0m	Straight Kit
T63943:	6.0m	Straight Kit	T63949:	12.0m	Straight Kit
T63944:	7.0m	Straight Kit	T63950:	13.0m	Straight Kit
T63945:	8.0m	Straight Kit	T63951:	14.0m	Straight Kit
T63946:	9.0m	Straight Kit	T63952:	15.0m	Straight Kit

# Line Operated Systems - Single Swipe

Six Track line operated systems are curtain tracks which use a hauling line which is operated:

- a. By hand with a weighted or floor mounted pulley.
- b. With a manual track drive which can be either floor or wall mounted.

Listed below are the components required to make a system.

Check List:

1. Track Sections
2. Suspension Brackets
3. Master Runner
4. Curtain Runners
5. End Stops
6. Fixing Kit (for joining track sections)
7. Twin Head Pulley
8. Return Pulley
9. Weighted pulley, floor mounted pulley, wall mounted track drive or floor mounted track drive.
10. Hauling Line
11. Line Supports (if required)
12. Single Guide Pulleys (if required)
13. Twin Guide Pulleys (required for curves)

Line supports and single guide pulleys are recommended on systems 5.0m and longer.

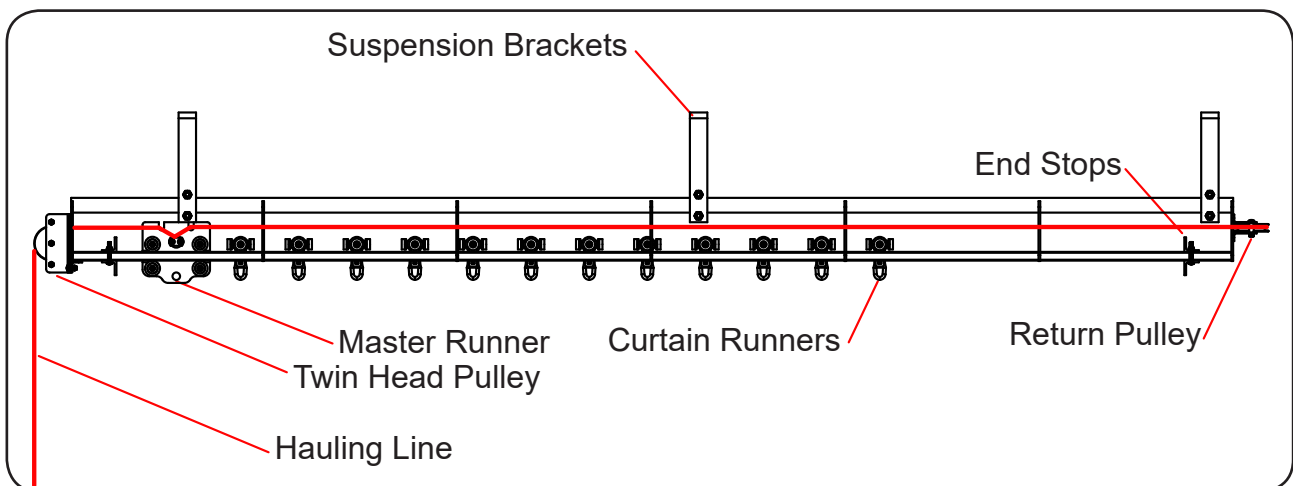

T63908:	4.0m	Straight Kit	T63914:	10.0m	Straight Kit
T63909:	5.0m	Straight Kit	T63915:	11.0m	Straight Kit
T63910:	6.0m	Straight Kit	T63916:	12.0m	Straight Kit
T63911:	7.0m	Straight Kit	T63917:	13.0m	Straight Kit
T63912:	8.0m	Straight Kit	T63918:	14.0m	Straight Kit
T63913:	9.0m	Straight Kit	T63919:	15.0m	Straight Kit



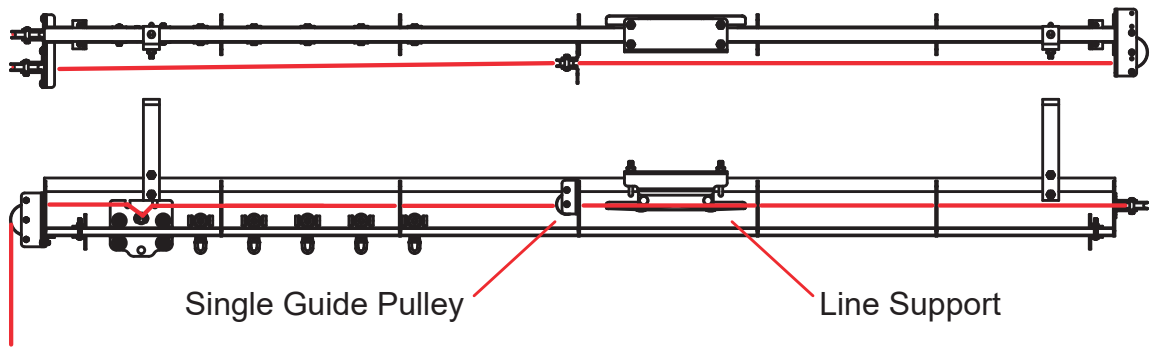

Single Guide Pulley

Line Support

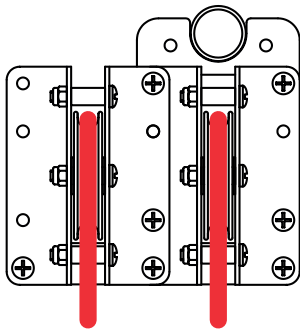

T63776: Twin Head Pulley

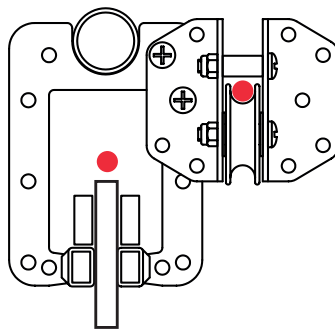

T63777: Single Guide Pulley

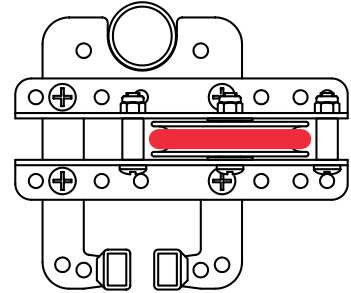

T63775: Return Pulley

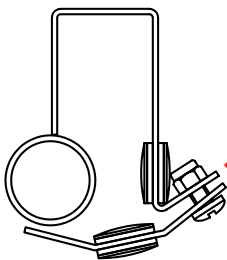

Step 1

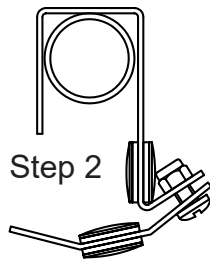

Step 2

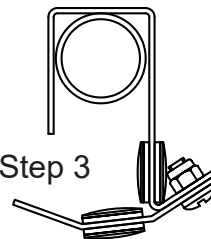

Step 3

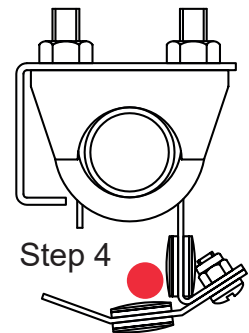

Step 4

Loosen

T63770: Line Support



Step 1



Step 2



Step 3

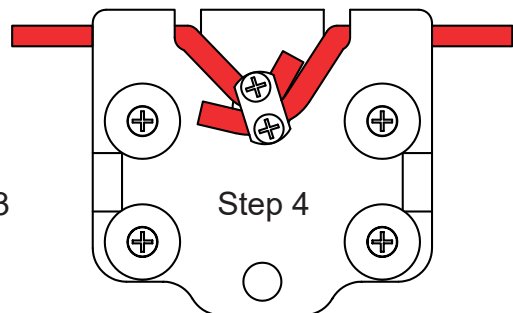

Step 4

T63775: Master Runner

# Line Operated Systems - Curves

Six Track line operated curves use double guide pulleys to guide the hauling line.

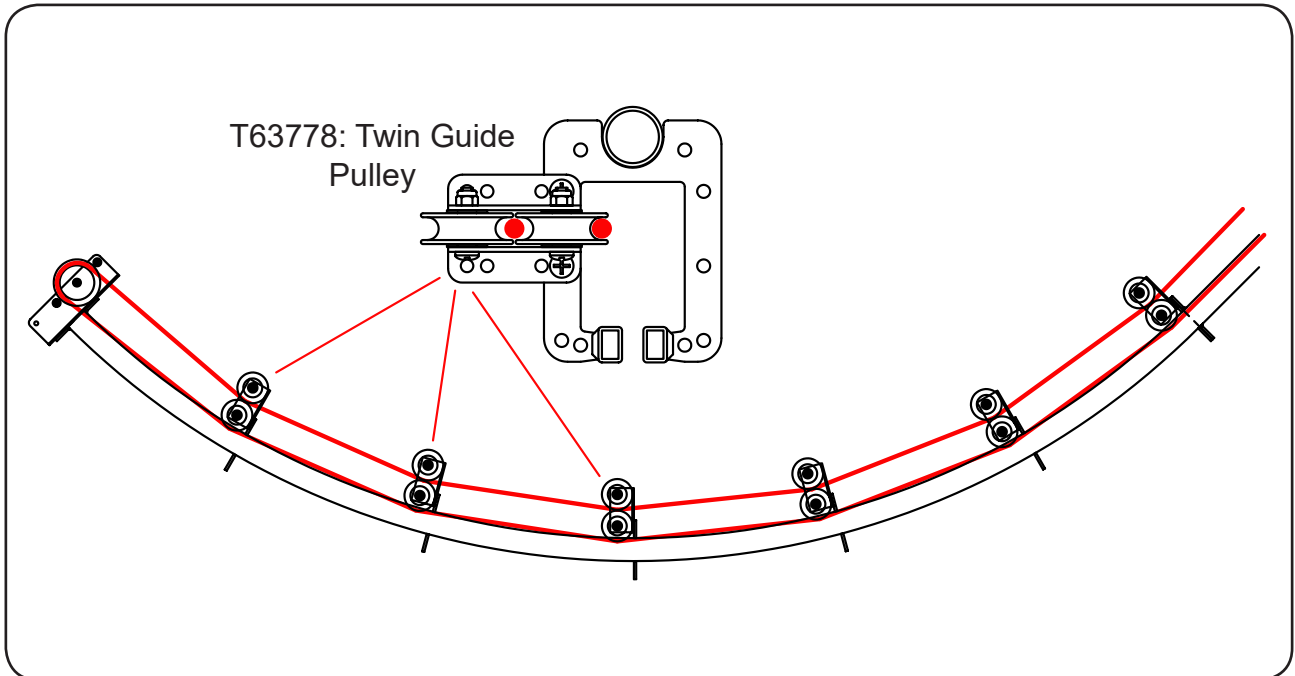

# Line Operated Systems - Crossover

Systems containing two or more curves may require the hauling line to crossover to enable the correct routing. This is achieved using two T63777: Single Guide Pulleys as below.

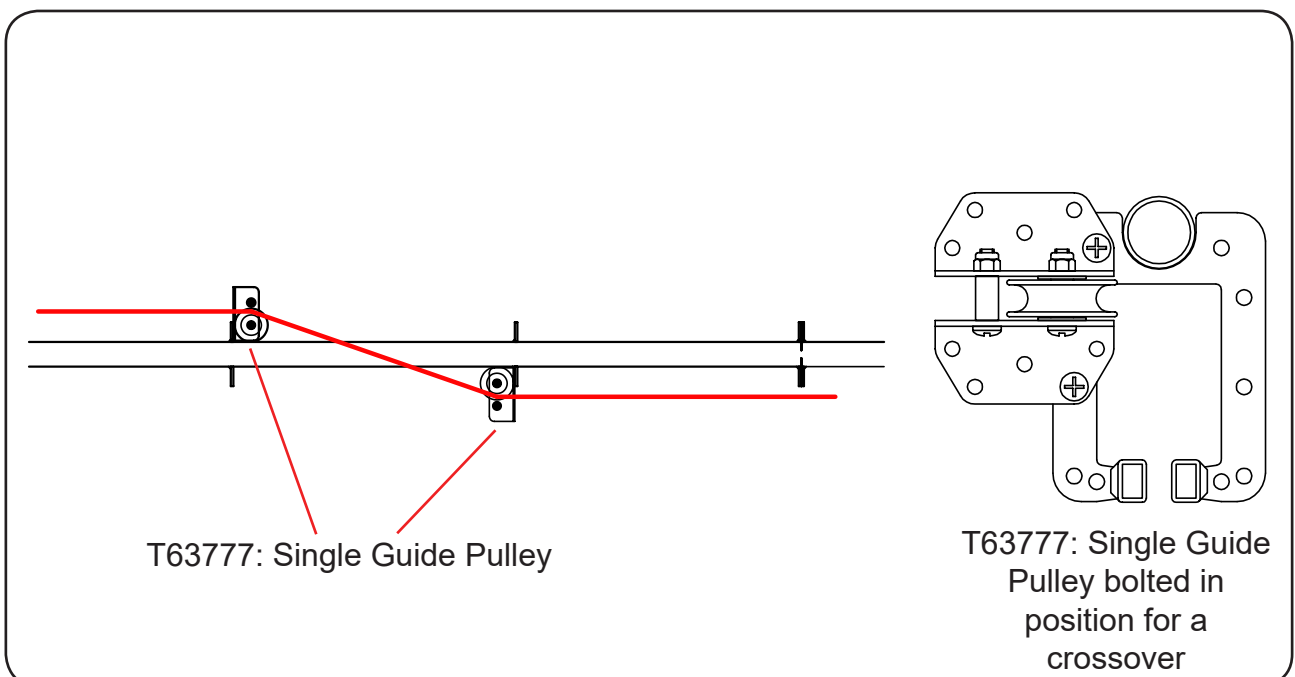

# Line Operated Systems - Overlap

Six Track line operated systems can be installed in an overlap configuration. This configuration requires the use of overlap brackets and twin guide pulleys.

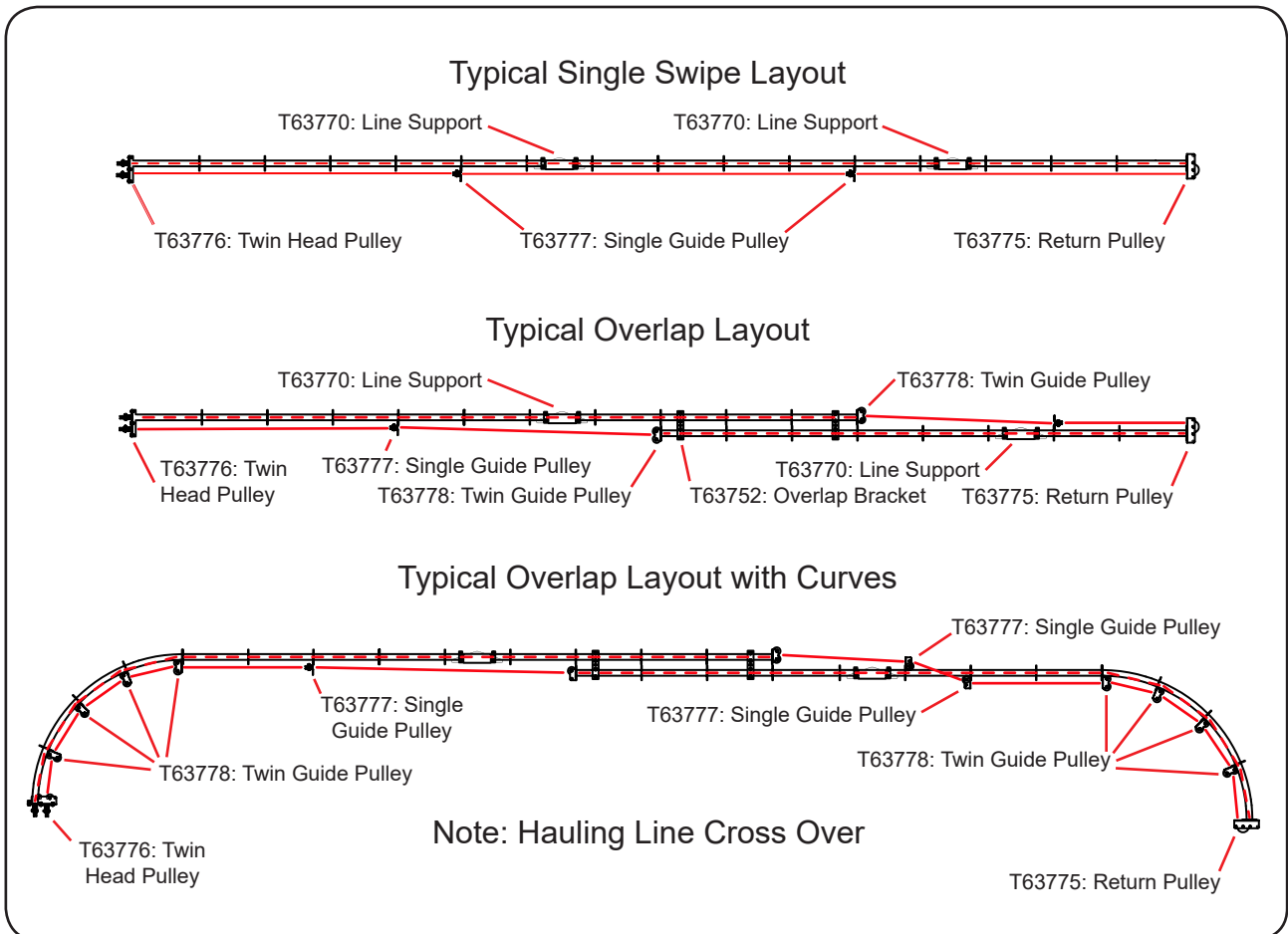
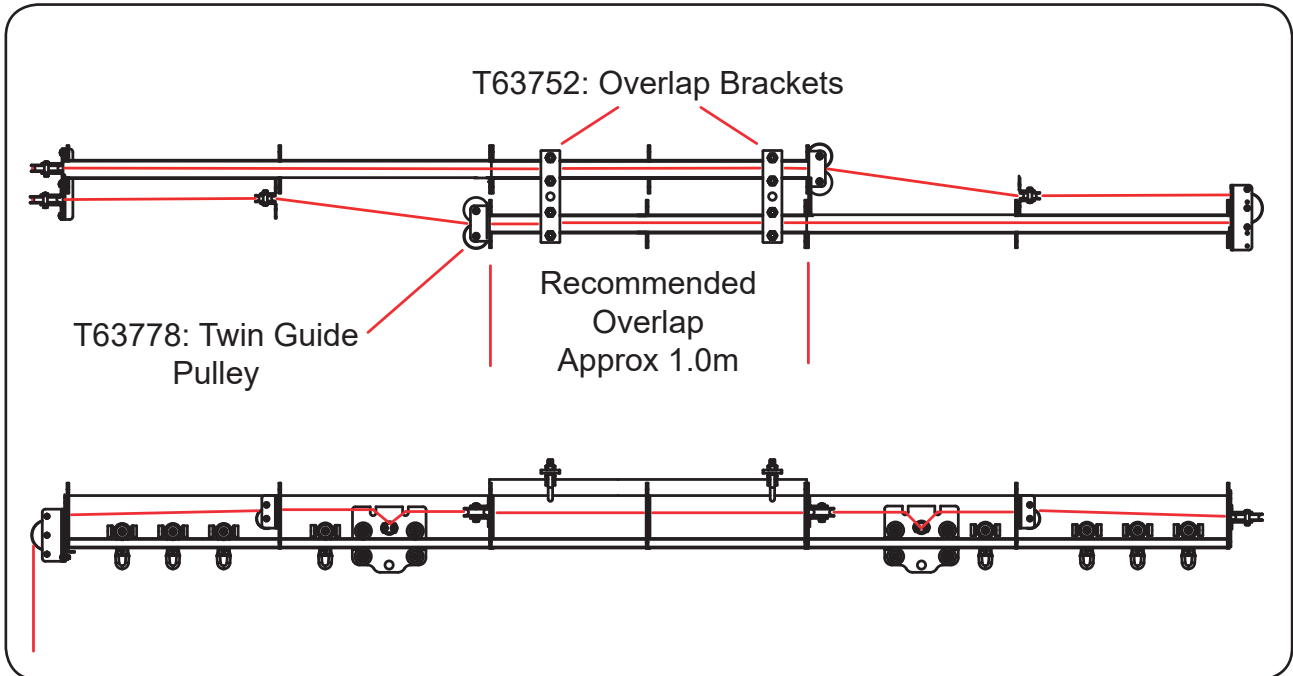

# Line Operated Systems - Hand drives

Six Track line operated systems can be operated either by hauling hand over hand or by turning a crank handle of a manual track drive unit.

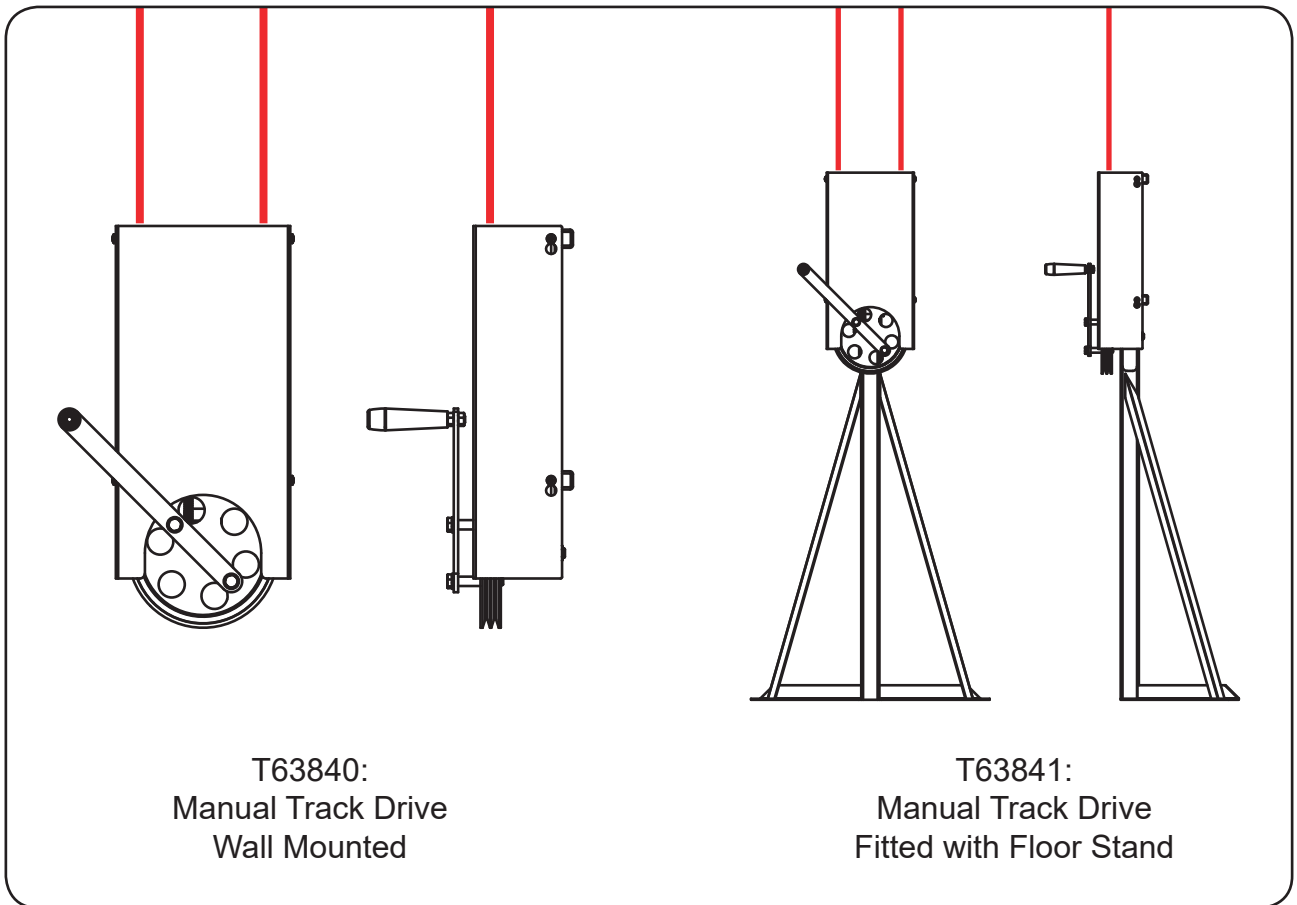
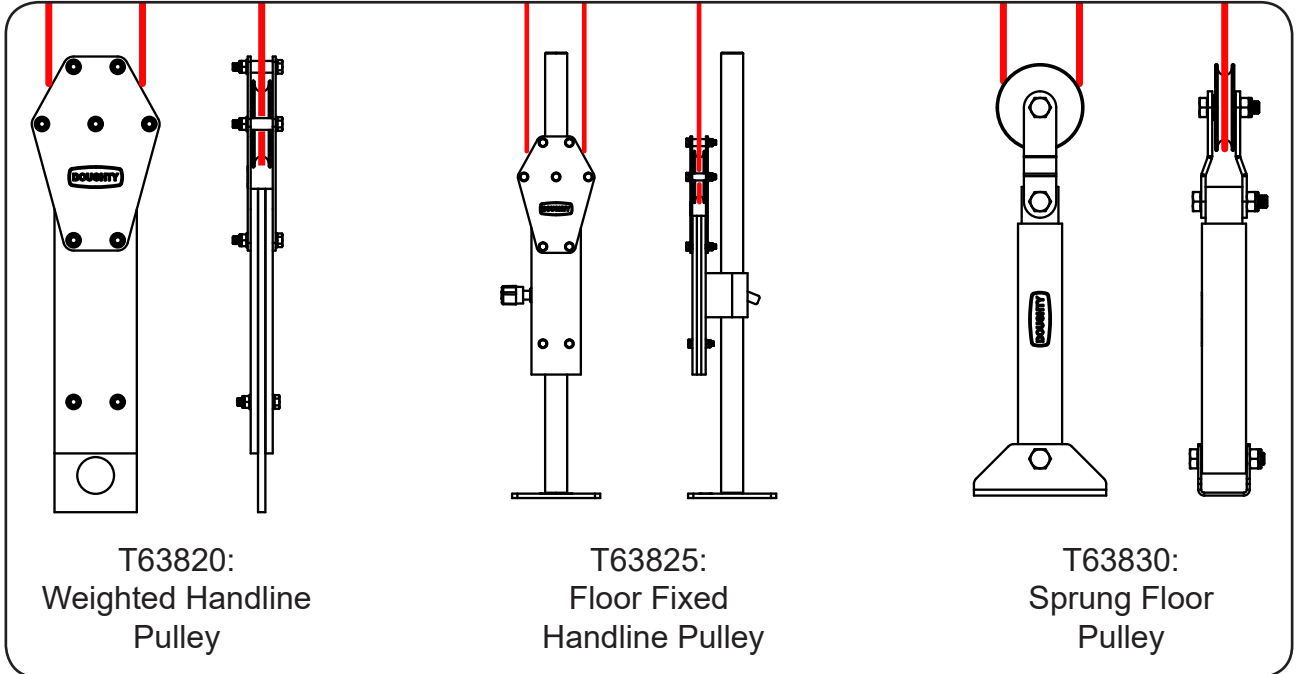

# PLC Electric Track Drive

The Six Track PLC Track Drive is a plug and play single phase electric track drive. The PLC control box enables a variable drive system, the control box is demountable and can be situated remotely if required.

The system uses a 0.12kw 50Hz motor capable of hauling up to 75Kg of drapes in a straight run and 50Kg when curves are used.

Two speeds are available up to 0.3m/sec and up to 0.7m/sec.

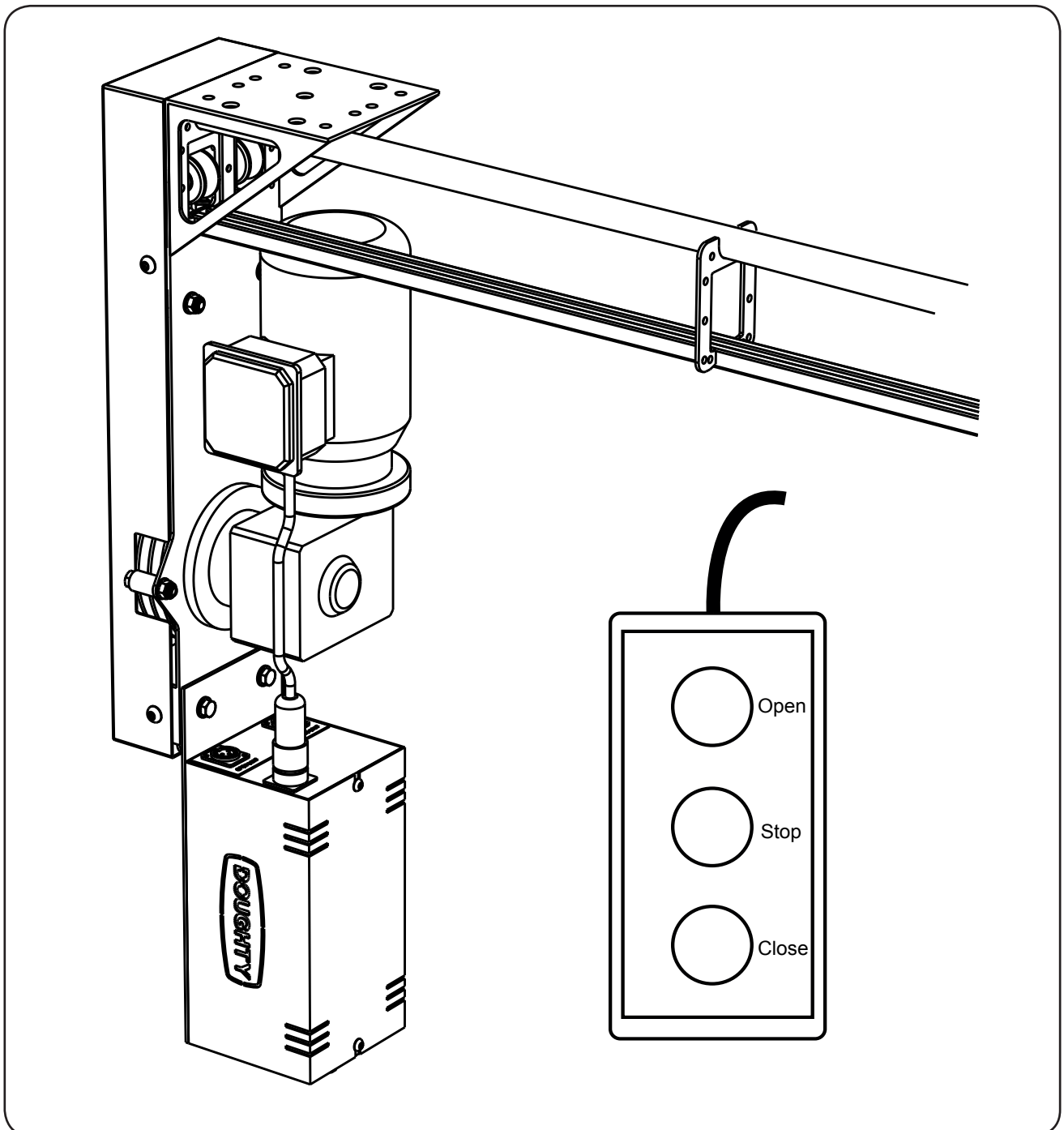

# PLC Electric Track Drive - Control Box

The Six Track PLC Control Box has been designed to be a plug and play installation.

The only wiring required is a 13amp plug when the power lead has been cut at the required length.

Limit Switches are connected with 2 x 3 pin XLR connections.

The standard pendant is connected with a 4 pin XLR connection and there is an optional pendant available with speed control which is connected with the 6 pin XLR connection.

If the Control Box is to be remotely situated plans should be made to either order the motor with the required length of cable fitted or a seek an electrician to wire a longer cable in place.

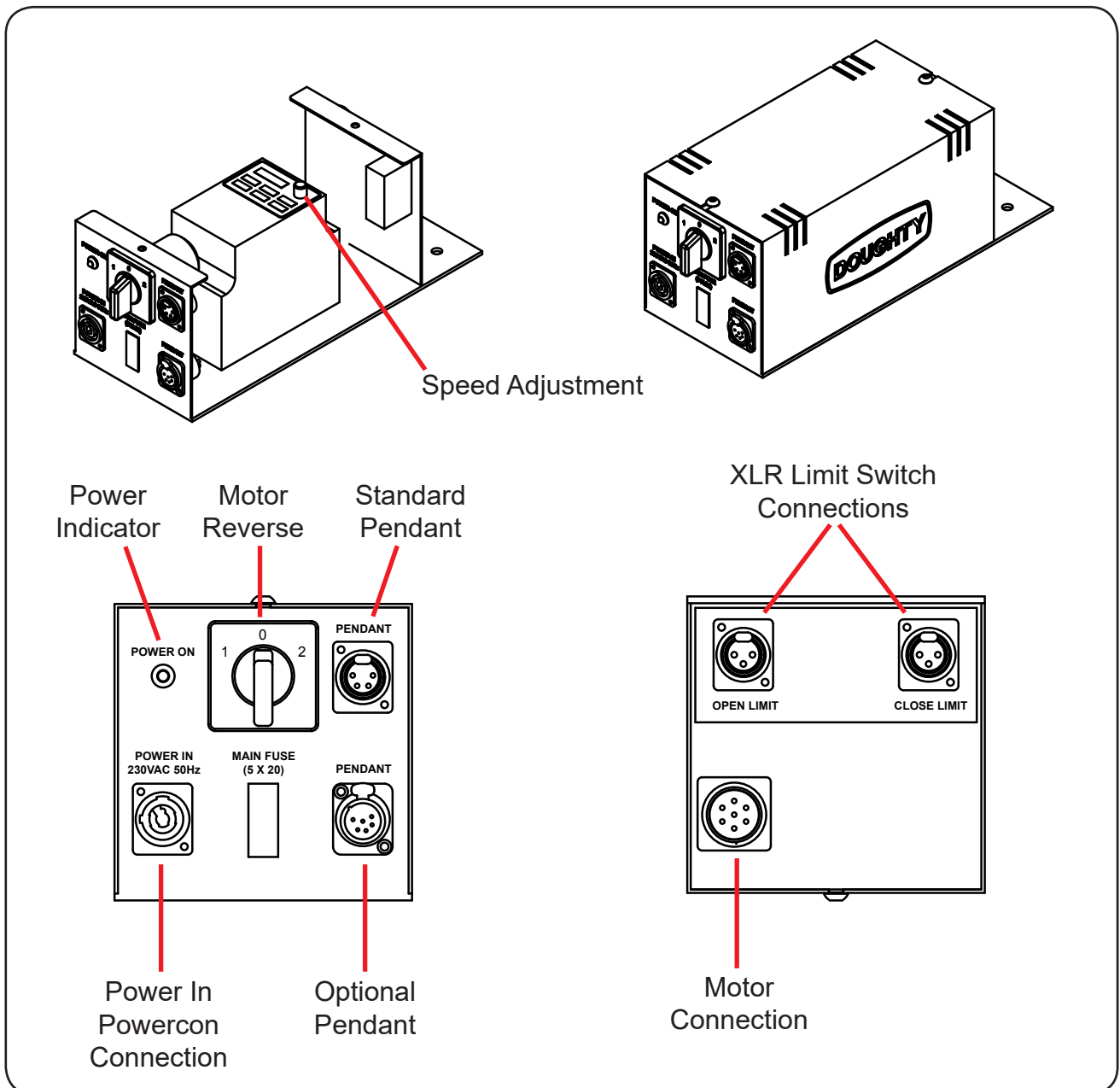

# PLC Electric Track Drive - Mounting

The Six Track PLC Track Drive can be track mounted or wall mounted.

Track mounted drives use two 'U' Bolts and standard fasteners from the Sixtrack fastener kit.

Wall mounted is achieved using two short lengths of unistrut as shown below.

Track drives can be remotely mounted off stage or in another room etc. with the careful use of diverter pulleys etc.

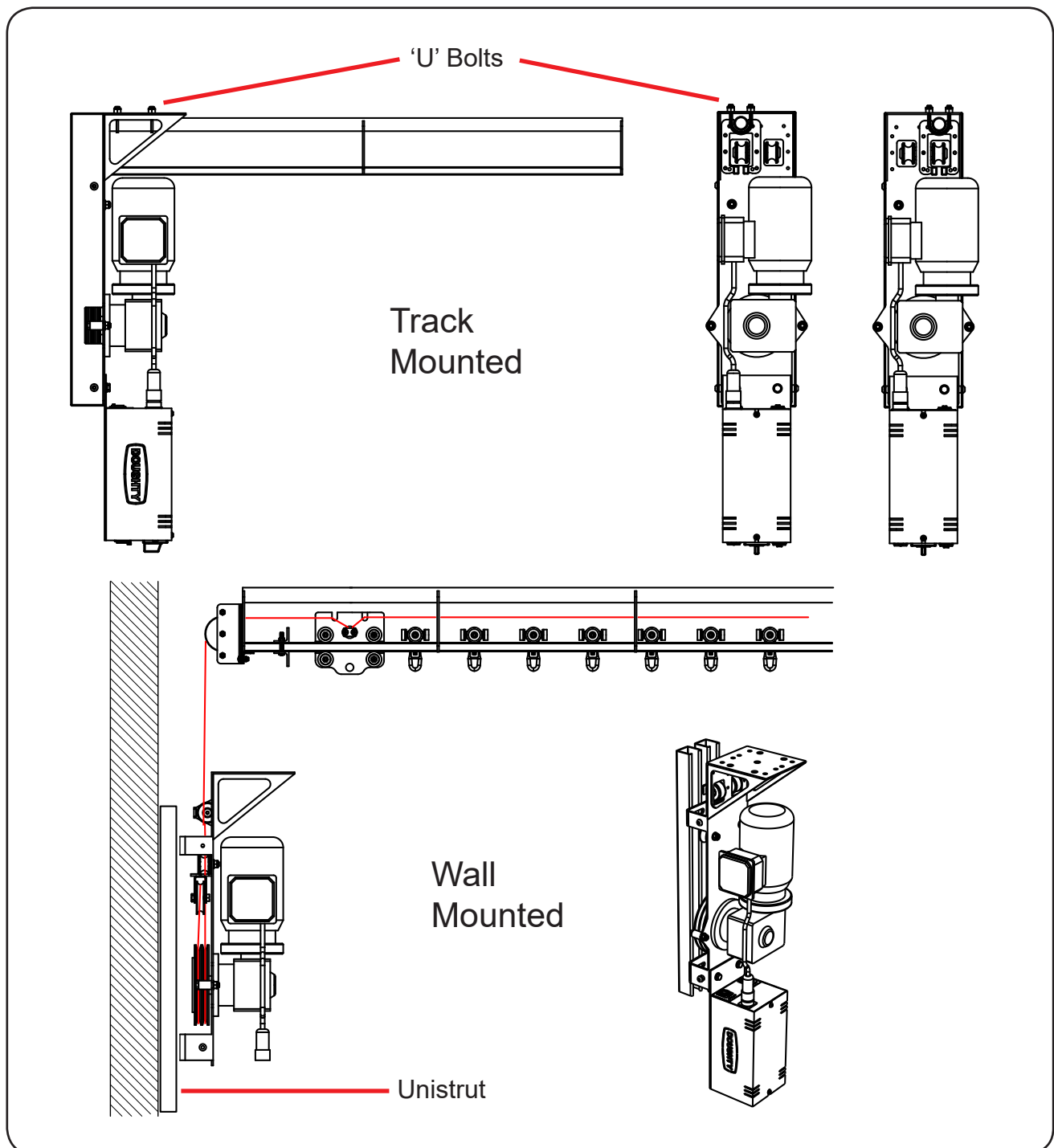

# PLC Electric Track Drive - Hauling Line

The diagram below shows the route of the hauling line through the guide pulleys and line tensioner. The tensioner spring must be compressed during the routing of the hauling line and when released should remain partially compressed to compensate for any line stretch.

In the case of the loss of drive the hauling line will need re-tensioning. The following steps are how to re-tension the hauling line.

1. **Disconnect the power lead.**
2. Compress the tensioner spring.
3. Loosen the rope clamp on the Master Runner.
4. Take up the slack line through the Master Runner.
5. Tighten the rope clamp on the Master Runner.
6. Release the tensioner spring ensuring it remains partially compressed.
7. Re-connect the power and test.

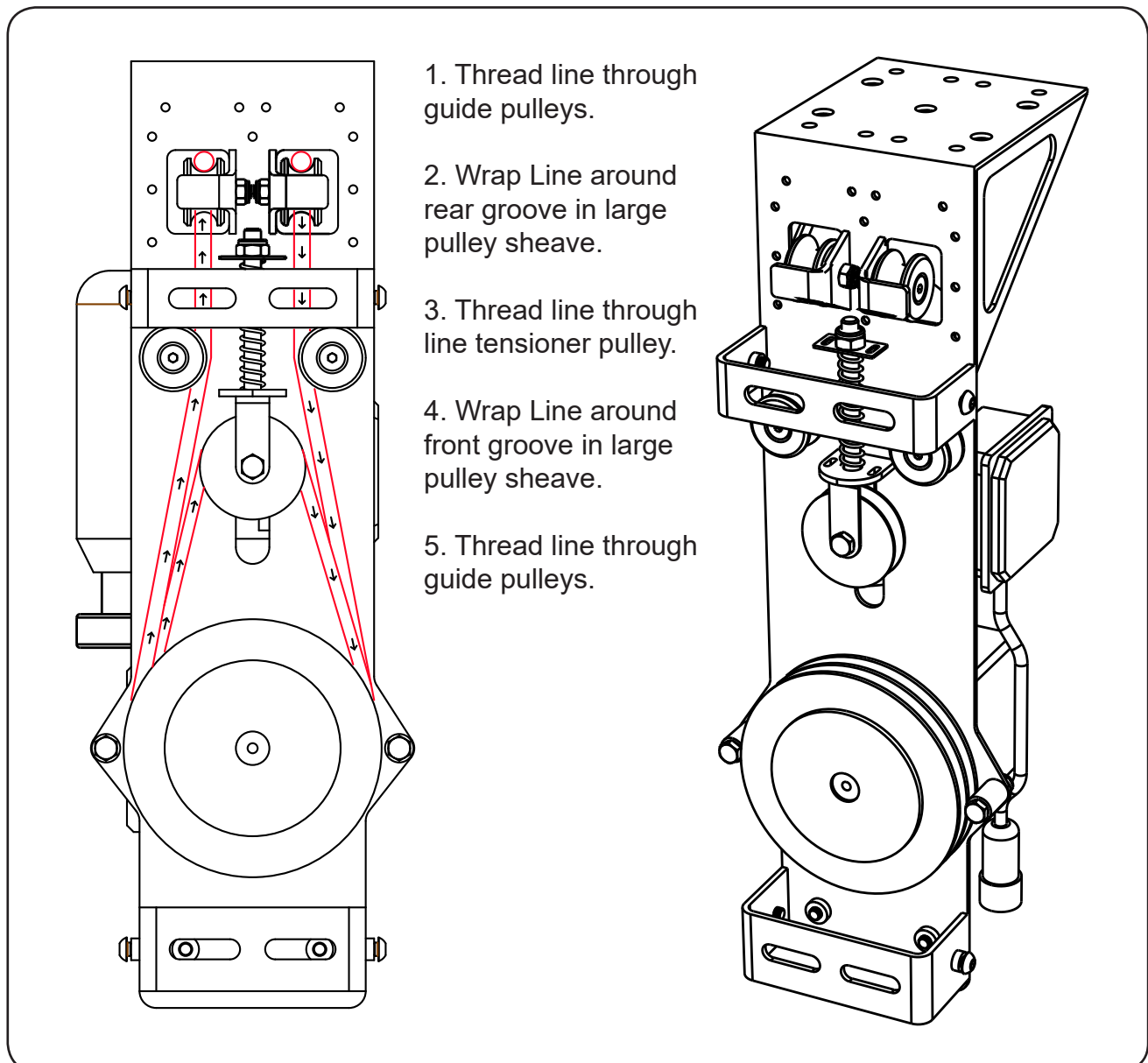



# PLC Electric Track Drive - Limit Switches

All motorised track systems must be fitted with two Limit Switches. The Limit Switches are activated manually by the Master Runner and create the open and closed stopping positions for curtain / scenery.

Ensure the Limit Switch wires are routed so they cannot come into contact with any moving parts.

The Limit Switches are connected to the drive control box xlr connections which are clearly marked 'open limit' and 'close limit'.

Failing to install the Limit Switches correctly can damage the track drive.

The diagram below shows a typical Limit Switch installation on the track.

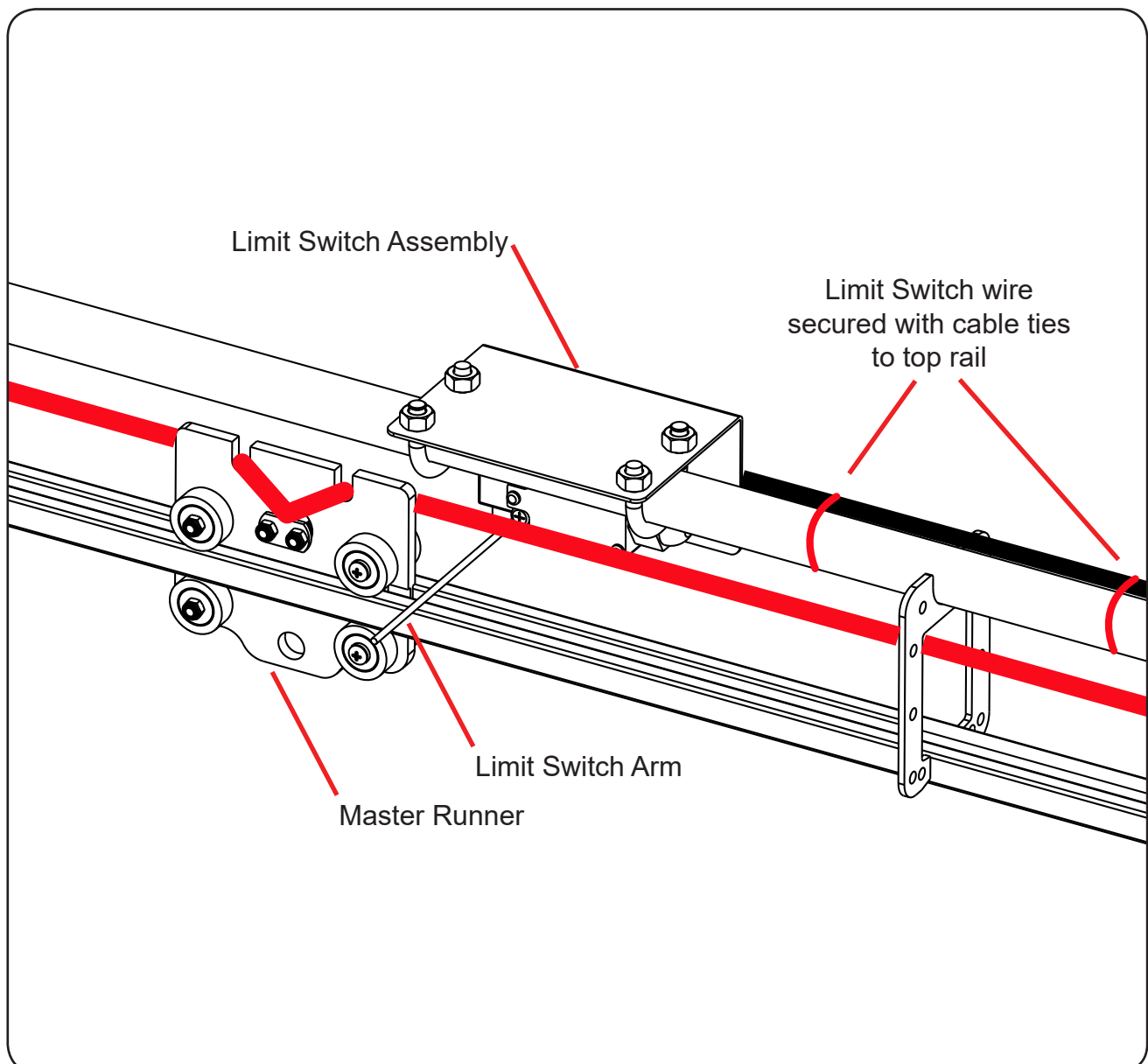

### Maintenance

- Maintenance must only be carried out by approved personnel.
- Approved personnel must make regular checks of the product.
- If you see any damage including cracks, deformation or missing parts, the product must be removed from service and returned to an Approved Service Agent for evaluation/repair.
- A full list of Approved Service Agents can be found on our website - [www.doughty-engineering.co.uk](http://www.doughty-engineering.co.uk).
- Approved personnel must carry out a visual and a function test before every usage.
- Approved personnel must carry out more detailed inspection and testing of the product on a regular basis depending on the usage of the product.
- Written records should be kept from the date the product is put into operation.



### Warning

- The installer/operator must read and understand the Instruction Manual before using the equipment.
- Operators must be adequately instructed and fully understand the safe use of the equipment before use.
- Failure to carry out maintenance as necessary, including the replacement of parts to the correct standard, could render this equipment unsafe and the manufacturer cannot accept any responsibility in this respect.

# Pendant Options

## PENS10

Pendant c/w Speed Pot (Optional)

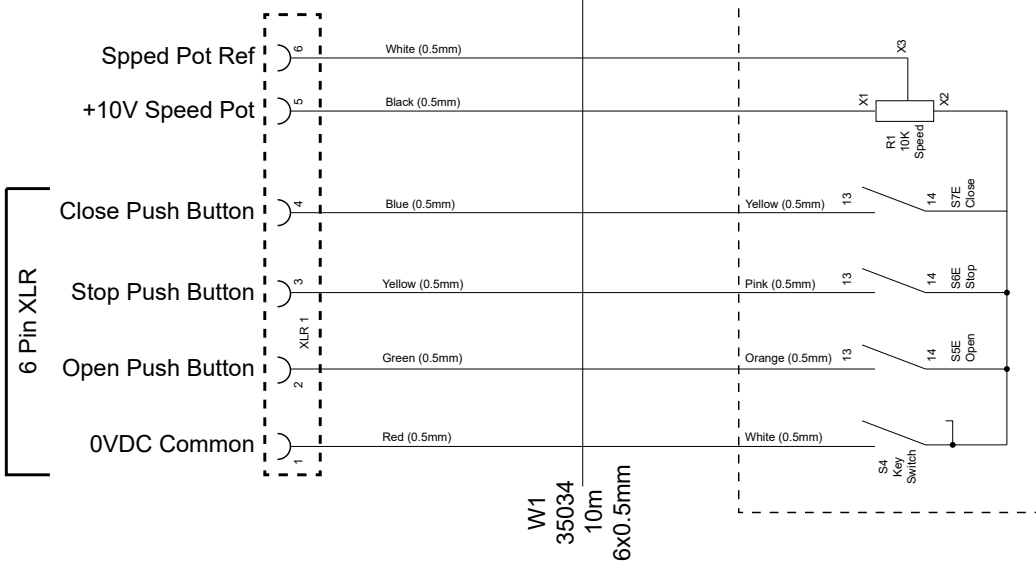

Pendant (399-3854)

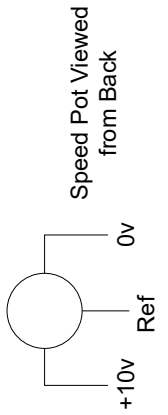

## PENK10

Pendant c/w Key Switch (Optional)

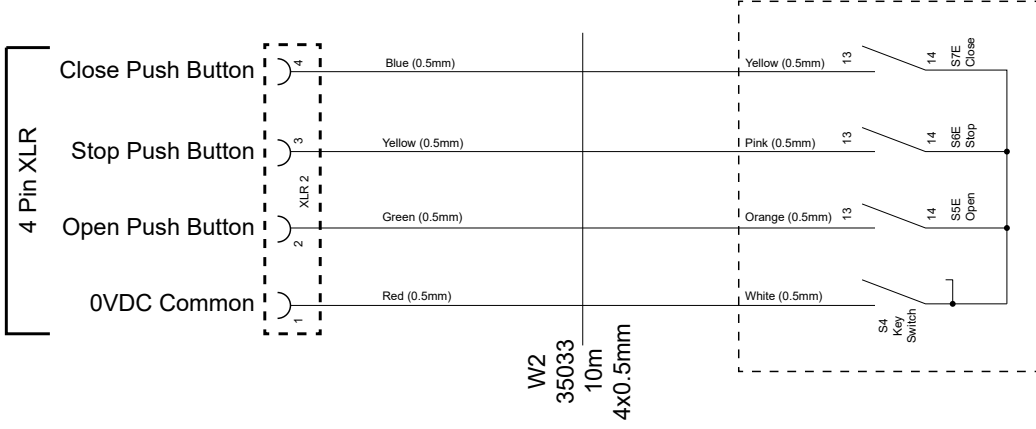

Pendant (399-3854)

## PENB10

Basic Pendant (Supplied as Standard)

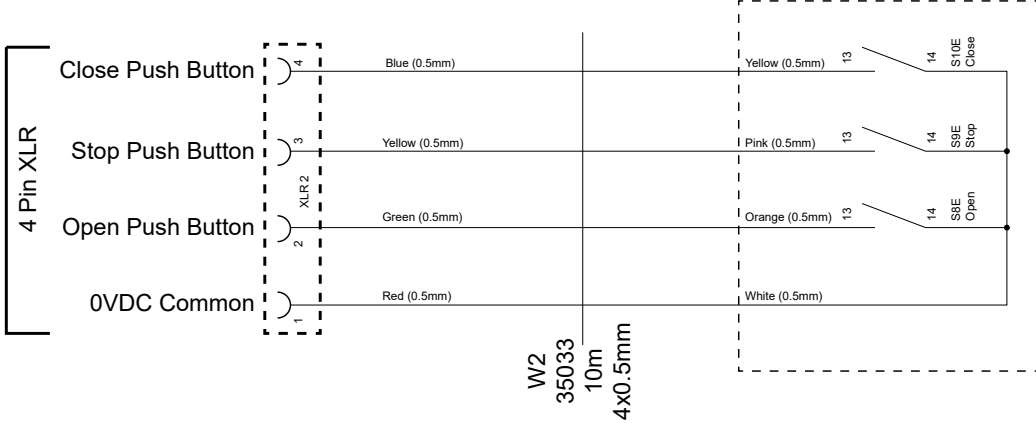

Pendant (399-3848)

# Limit Options

## 3 Pin XLR

Close Limit Return  
0VDC Common

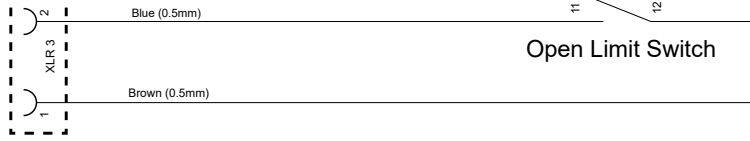

## 3 Pin XLR

Close Limit Return  
0VDC Common

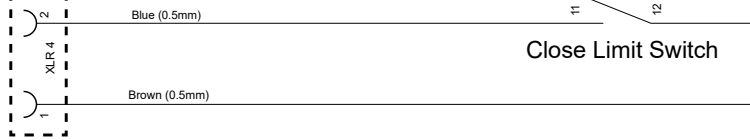

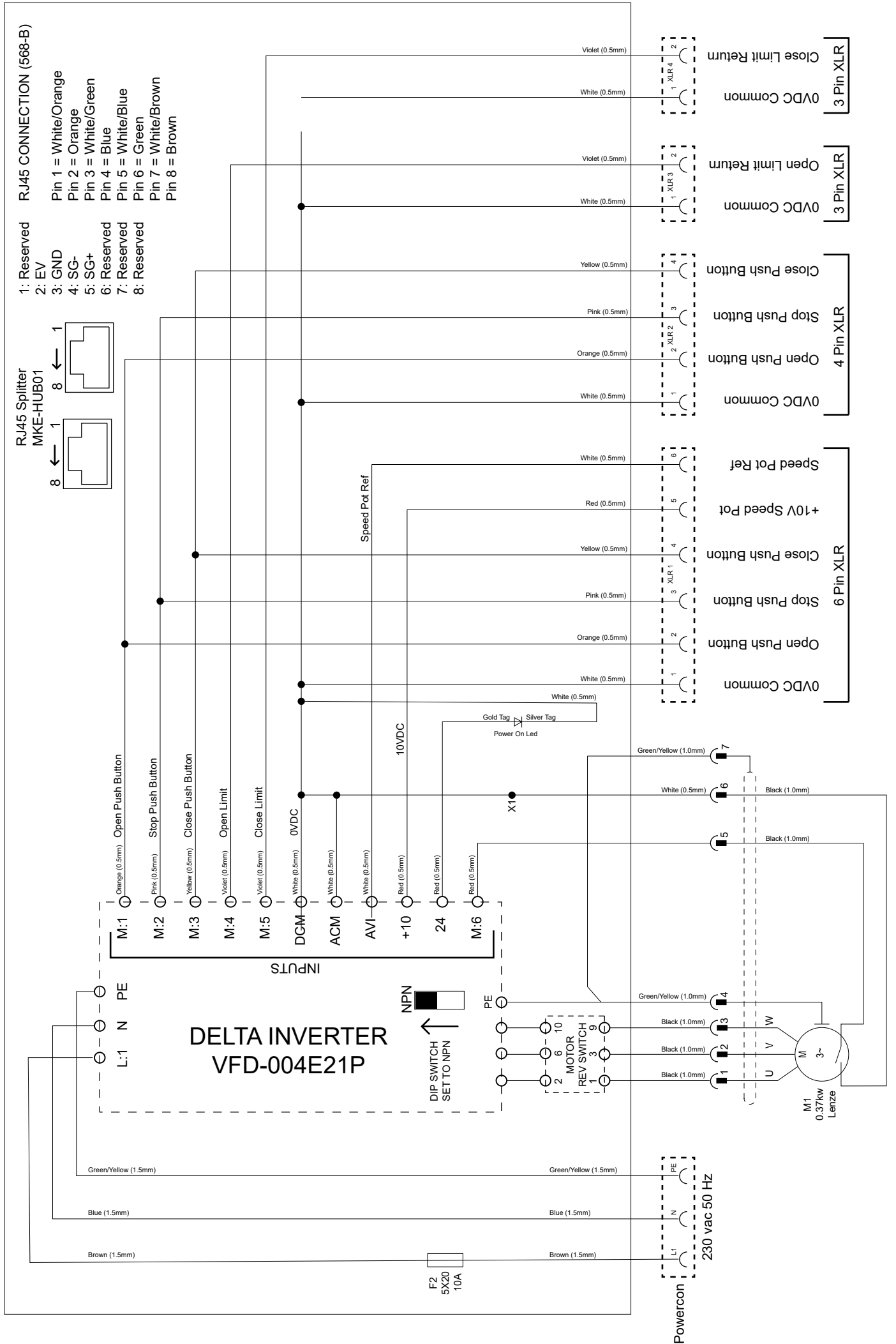

**RJ45 CONNECTION (568-B)**

- 1: Reserved
- 2: EV
- 3: GND
- 4: SG-
- 5: SG+
- 6: Reserved
- 7: Reserved
- 8: Reserved

- Pin 1 = White/Orange
- Pin 2 = Orange
- Pin 3 = White/Green
- Pin 4 = Blue
- Pin 5 = White/Blue
- Pin 6 = Green
- Pin 7 = White/Brown
- Pin 8 = Brown

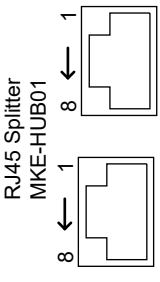

## DELTA INVERTER VFD-004E21P

INPUTS



**Powercon**  
230 vac 50 Hz

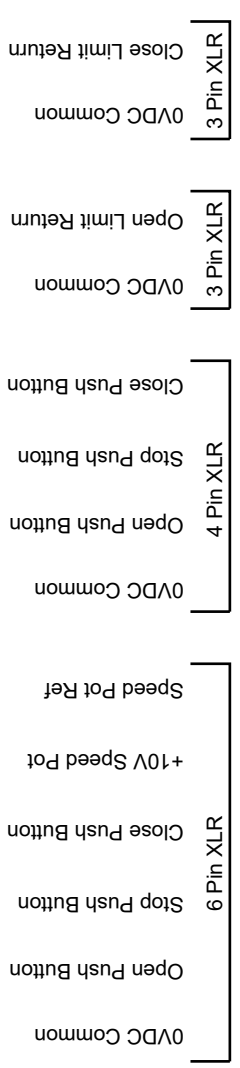
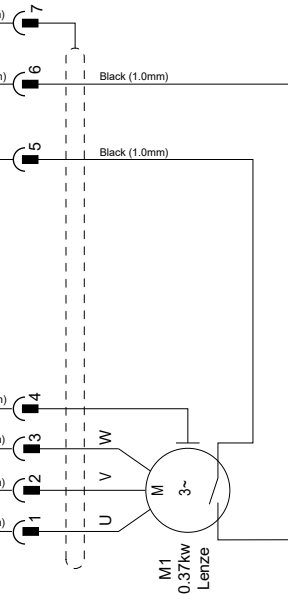

F2 5X20 10A





**Doughty Engineering Ltd**

Crow Arch Lane

Ringwood, Hampshire, BH24 1NZ

Tel: +44 (0) 1425 478961 Fax: +44 (0) 1425 474481

email: [sales@doughty-engineering.co.uk](mailto:sales@doughty-engineering.co.uk)

Web: [www.doughty-engineering.co.uk](http://www.doughty-engineering.co.uk)

Note: Whilst every effort has been made to ensure that the information contained within this manual is correct, Doughty Engineering does not accept any liability for errors or omissions. Specifications and technical data are intended for guidance purposes only and may vary.